

GSMT Integrated Modeling: Our Approach and Status

George Angeli

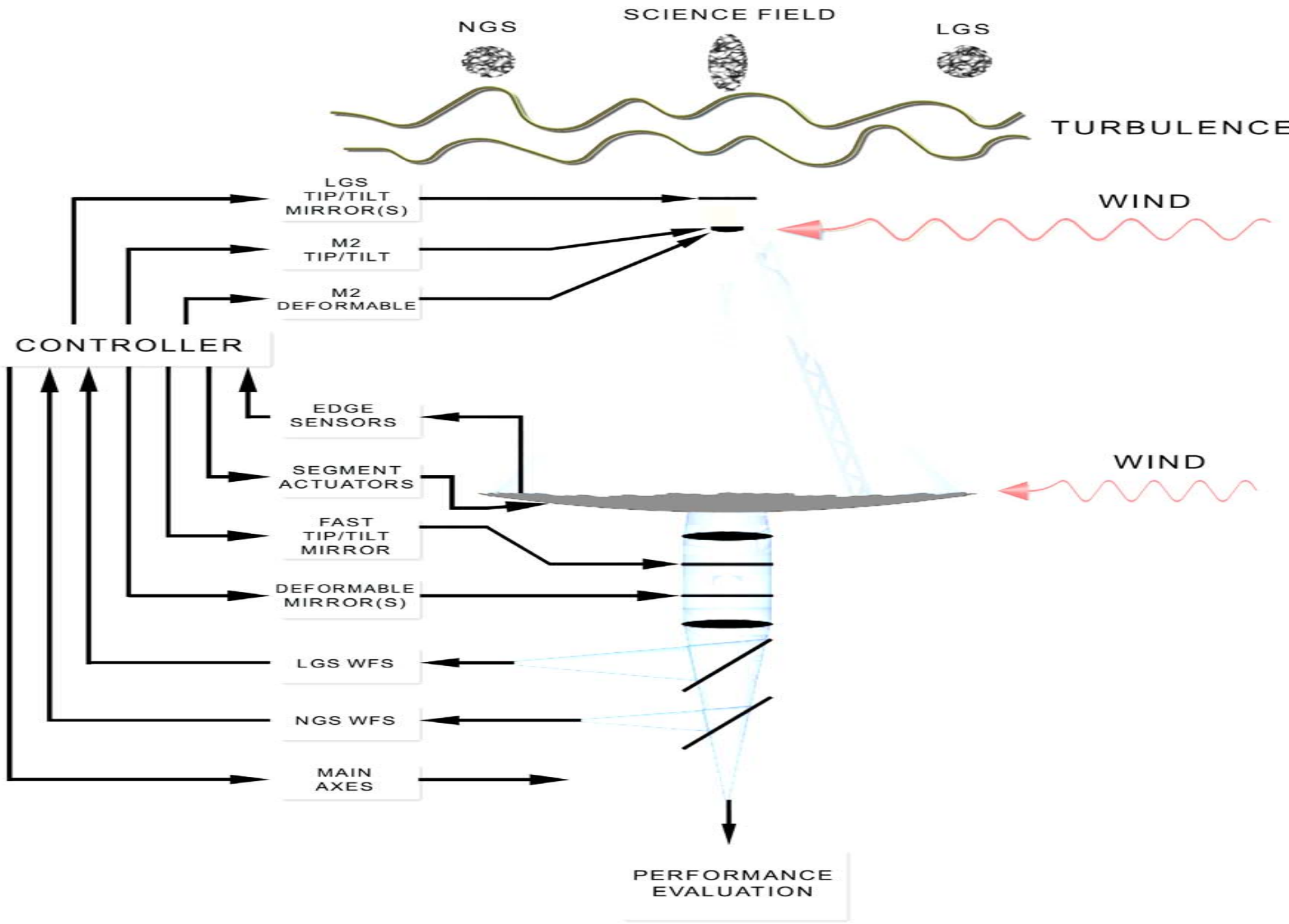



Iterative design process

AURA NEW INITIATIVES OFFICE

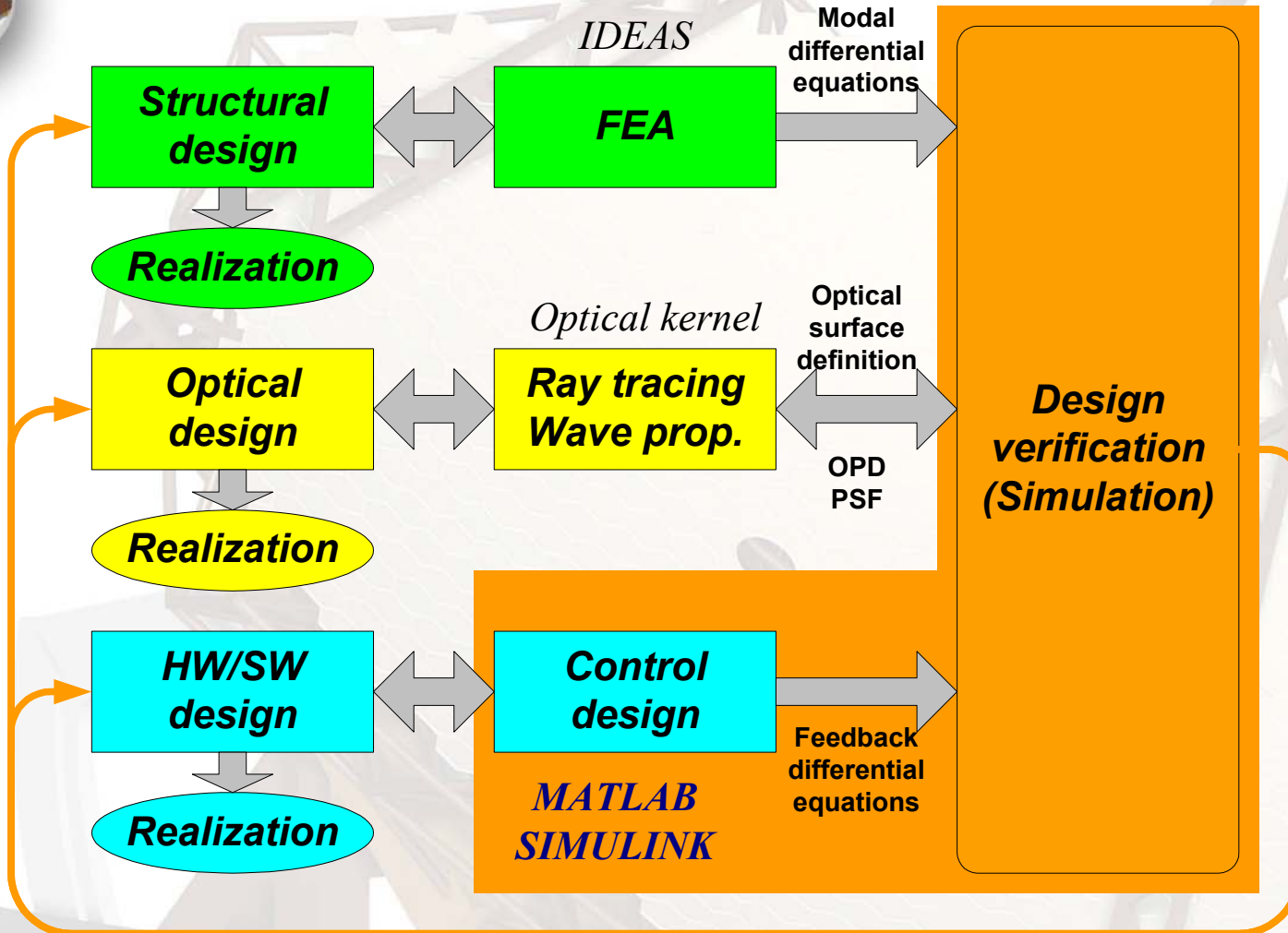

Integrated model

AURA NEW INITIATIVES OFFICE

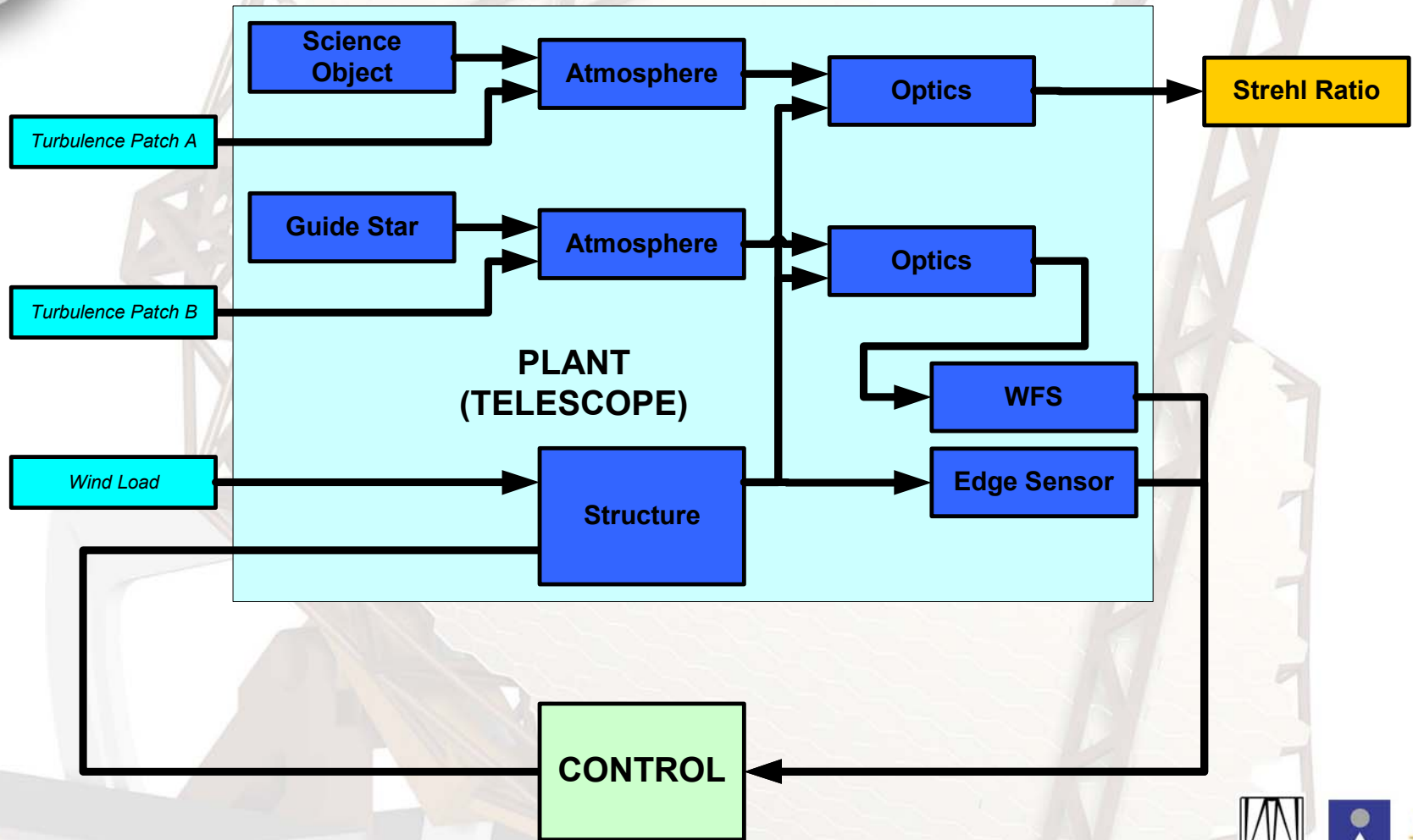

Modeling approaches

AURA NEW INITIATIVES OFFICE

Linear model

- Helps understanding the underlying physics
- Facilitates control design
- Essentially modal (global)
- Colored (filtered) white noise disturbances
- Limited size (truncated) model

Nonlinear model

- Estimates telescope performance
- Verifies control design
- Essentially zonal (local)
- Measured or pre-calculated (CFD) disturbances
- Full (larger) model
- **Computationally intensive**



Cluster



Modeling tools

AURA NEW INITIATIVES OFFICE

Linear model

- **Modeling**
 - Finite element model & import path
 - Linear optical model
 - Linear wind model
- **Model preparation**
 - Model reduction
 - Model conditioning
- **Analysis**
 - Disturbance
 - Uncertainty
- **Control design**
 - Sensitivity analysis
 - Isoperformance analysis
 - Optimization

Nonlinear model

- **Modeling**
 - Finite element model & import path
 - Optical model & interface to ray tracing
 - CFD wind model & import path
- **Model preparation**
 - Sub-model reduction
 - Sub-model conditioning
- **Analysis**
 - Disturbance/performance analysis
- **Control design**
 - ?



Modeling tools

AURA NEW INITIATIVES OFFICE

Linear model

- **Modeling**
 - **Finite element model & import path**
 - **Linear optical model**
 - **Linear wind model**
- **Model preparation**
 - **Model reduction**
 - **Model conditioning**
- **Analysis**
 - **Disturbance**
 - **Uncertainty**
- **Control design**
 - **Sensitivity analysis**
 - **Isoperformance analysis**
 - **Optimization**

Nonlinear model

- **Modeling**
 - **Finite element model & import path**
 - **Optical model & interface to ray tracing**
 - **CFD wind model & import path**
- **Model preparation**
 - **Sub-model reduction**
 - **Sub-model conditioning**
- **Analysis**
 - **Disturbance/performance analysis**
- **Control design**
 - ?



Description of structural dynamics

AURA NEW INITIATIVES OFFICE

Nodal representation

$$\mathbf{M}\ddot{\mathbf{q}} + \mathbf{D}\dot{\mathbf{q}} + \mathbf{K}\mathbf{q} = \mathbf{B}_0\mathbf{u}$$

$$\mathbf{y} = \mathbf{C}_{0q}\mathbf{q} + \mathbf{C}_{0v}\dot{\mathbf{q}}$$

Modal representation

$$\ddot{\mathbf{q}}_m + 2\mathbf{Z}\Omega\dot{\mathbf{q}}_m + \Omega^2\mathbf{q}_m = \mathbf{B}_m\mathbf{u}$$

$$\mathbf{y} = \mathbf{C}_{mq}\mathbf{q}_m + \mathbf{C}_{mv}\dot{\mathbf{q}}_m$$

State space representation

$$\dot{\mathbf{x}} = \mathbf{A}\mathbf{x} + \mathbf{B}\mathbf{u}$$

$$\mathbf{y} = \mathbf{C}\mathbf{x}$$

$$\mathbf{x} = \begin{bmatrix} \mathbf{x}_1 \\ \mathbf{x}_2 \end{bmatrix} = \begin{bmatrix} \mathbf{q}_m \\ \dot{\mathbf{q}}_m \end{bmatrix}$$

$$\dot{\mathbf{x}} = \begin{bmatrix} \mathbf{0} & \mathbf{I} \\ -\Omega^2 & -2\mathbf{Z}\Omega \end{bmatrix} \mathbf{x} + \begin{bmatrix} \mathbf{0} \\ \mathbf{I} \end{bmatrix} \mathbf{B}_m\mathbf{u}$$

$$\mathbf{y} = [\mathbf{C}_{mq} \quad \mathbf{C}_{mv}] \mathbf{x}$$

$$\dot{\mathbf{x}} = \begin{bmatrix} \mathbf{0} & \mathbf{I} \\ -\Omega^2 & -2\mathbf{Z}\Omega \end{bmatrix} \mathbf{x} + \begin{bmatrix} \mathbf{0} \\ \mathbf{I} \end{bmatrix} (\mathbf{B}_1\mathbf{u}_1 + \mathbf{B}_2\mathbf{u}_2 + \mathbf{B}_3\mathbf{u}_3 + \dots)$$

$$\mathbf{y}_1 = [\mathbf{I} \quad \mathbf{0}] \mathbf{C}_1 \mathbf{x}$$

$$\mathbf{y}_2 = [\mathbf{I} \quad \mathbf{0}] \mathbf{C}_2 \mathbf{x}$$



Structural dynamics

AURA NEW INITIATIVES OFFICE

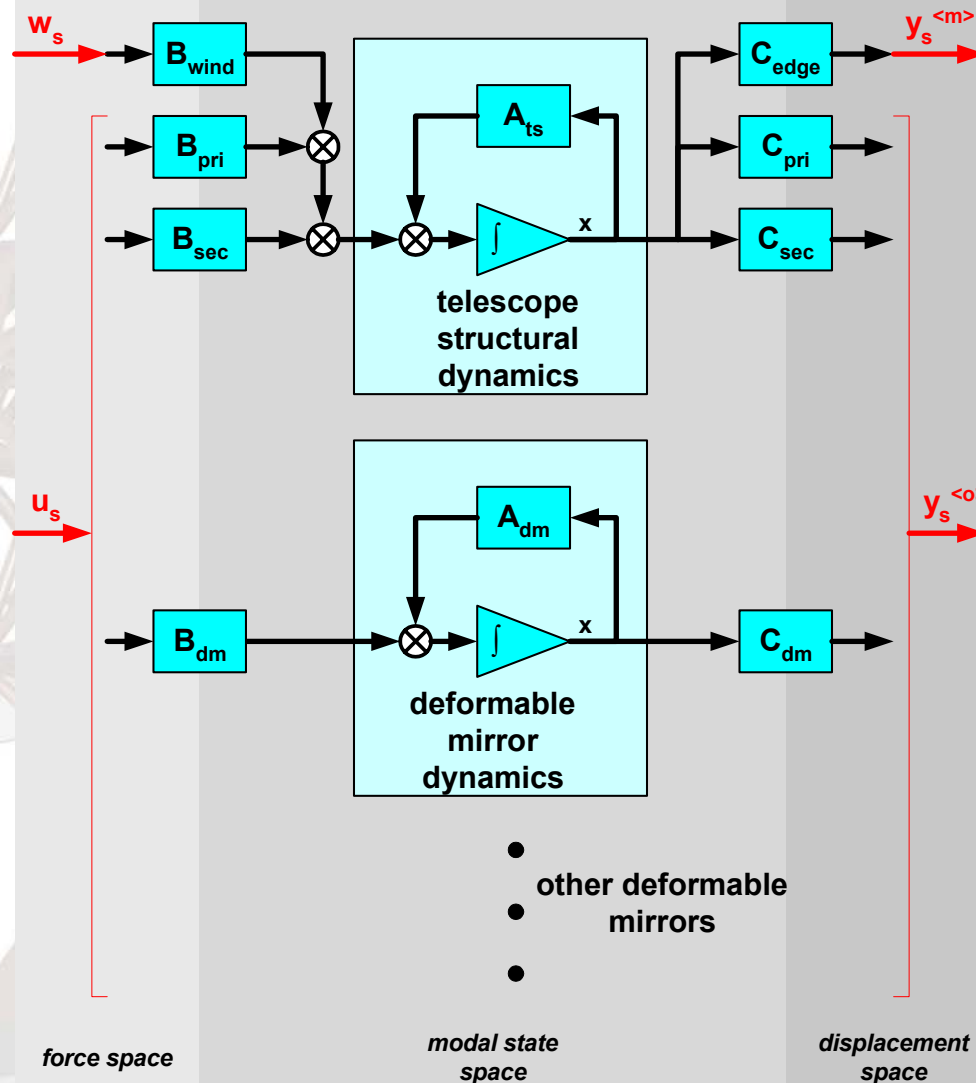

Interface to FEA

AURA NEW INITIATIVES OFFICE

- **IMAT**
 - **Toolbox in Matlab**
 - **Read/writes IDEAS universal files**
 - **Generates Matlab structure for all FEA (linear) results**
- **Matlab scripts**
 - **Generate state space representation**
 - **Visualize model**



Optical model for a single path

AURA NEW INITIATIVES OFFICE

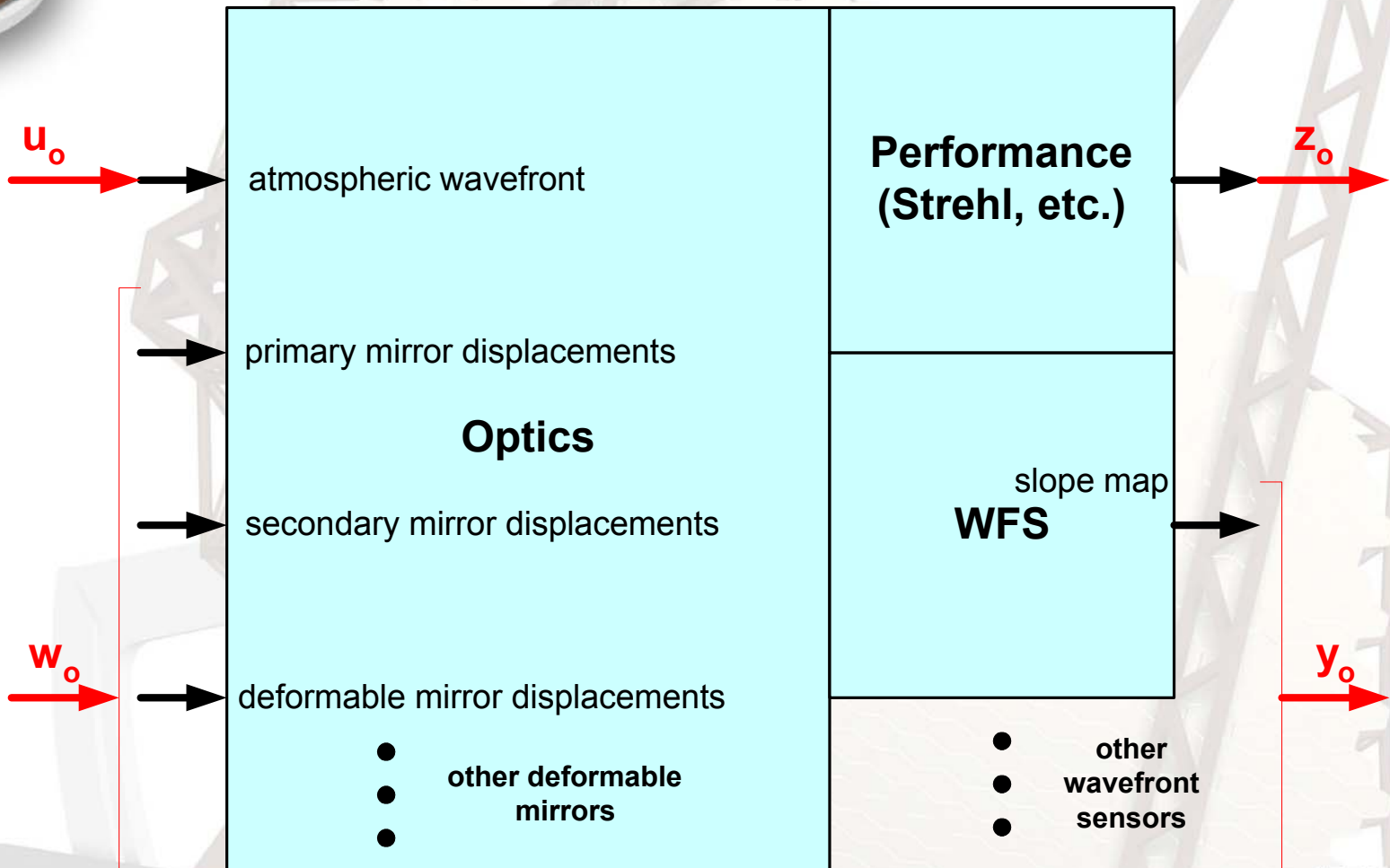

Linear optical model

AURA NEW INITIATIVES OFFICE

OPD @ exit pupil $\rightarrow \epsilon = \mathbf{K} \mathbf{q}_0 \leftarrow$ Subset of nodal coordinates (DoFs)

K can be huge
Already an approximation

Modal representation and reduction

SVD of K

- Nodal (\mathbf{q}_0) modes are NOT structural modes
- OPD (ϵ) modes are NOT Zernikes

Direct link

- Nodal (\mathbf{q}_0) modes ARE the structural modes
- OPD (ϵ) modes ARE the Zernikes

$$\mathbf{a}_{\text{system}} = \mathbf{a}_{\text{atmosphere}} + \mathbf{S}_{\text{primary}} \mathbf{b}_{\text{primary}} + \mathbf{S}_{\text{secondary}} \mathbf{b}_{\text{secondary}}$$



GSMT image quality

AURA NEW INITIATIVES OFFICE

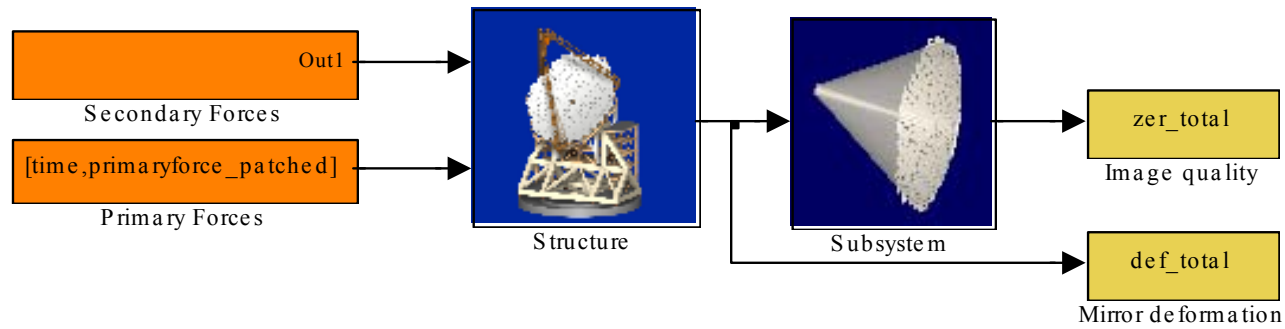

GSMT: OPD Zernike #1

AURA NEW INITIATIVES OFFICE

Tip

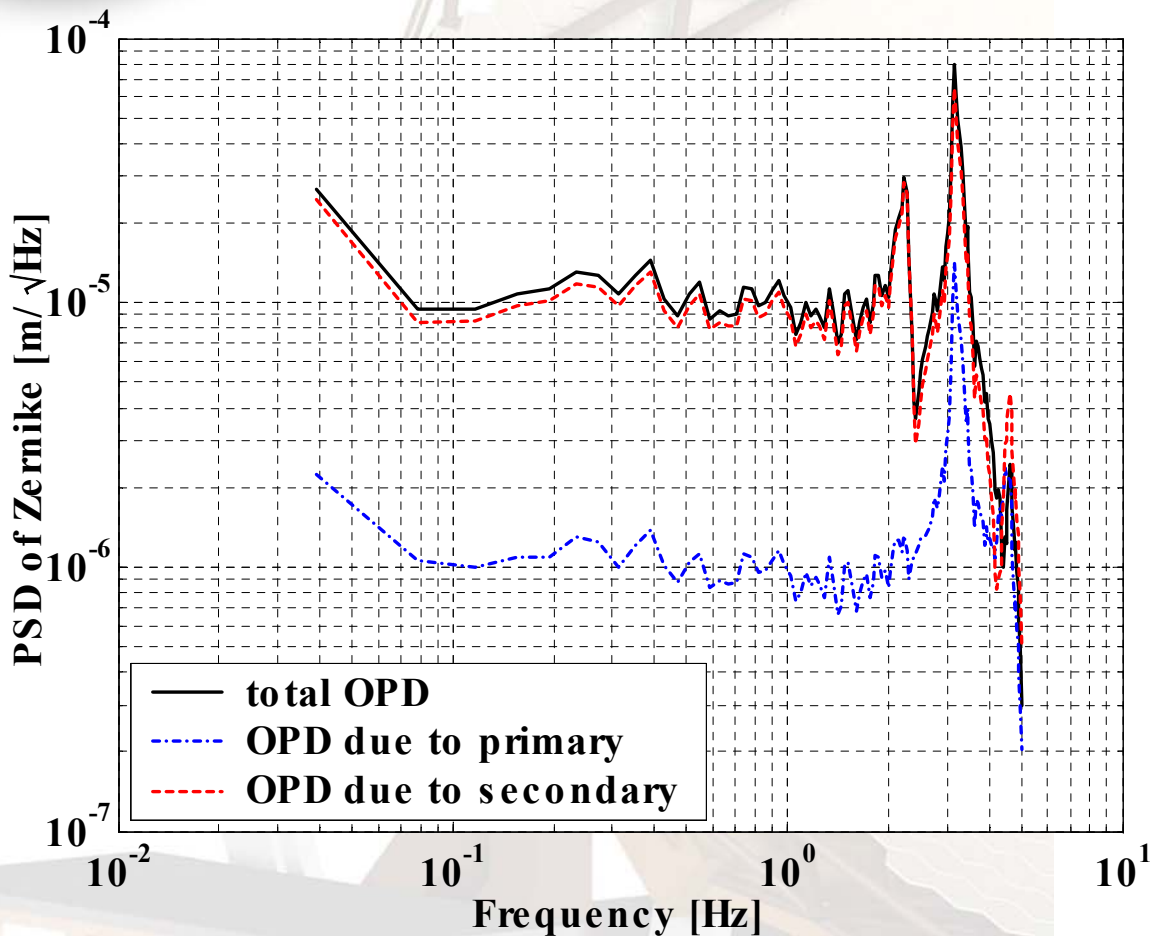

Mode #2:
2.24 Hz

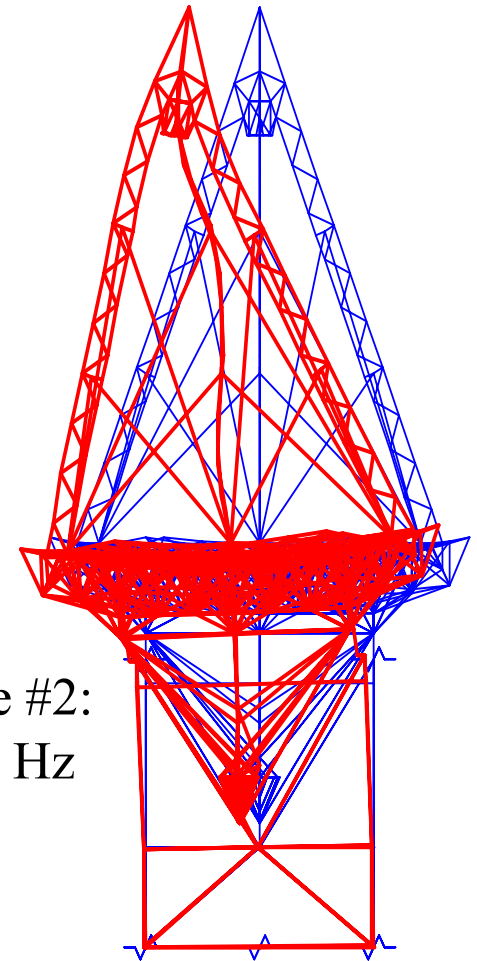
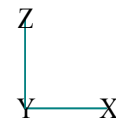

GSMT: OPD Zernike #1 (cont.)

AURA NEW INITIATIVES OFFICE

Tip

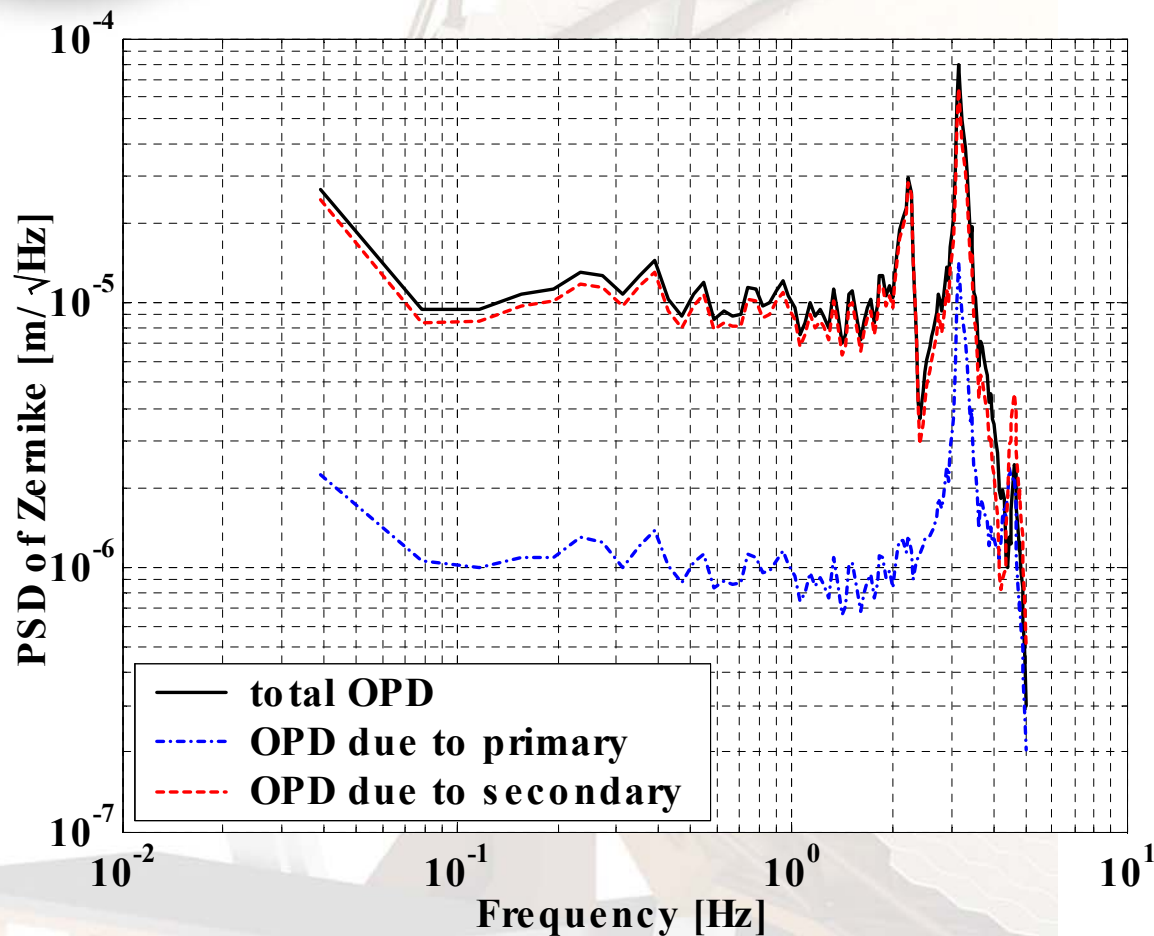

Mode #4:
3.09 Hz

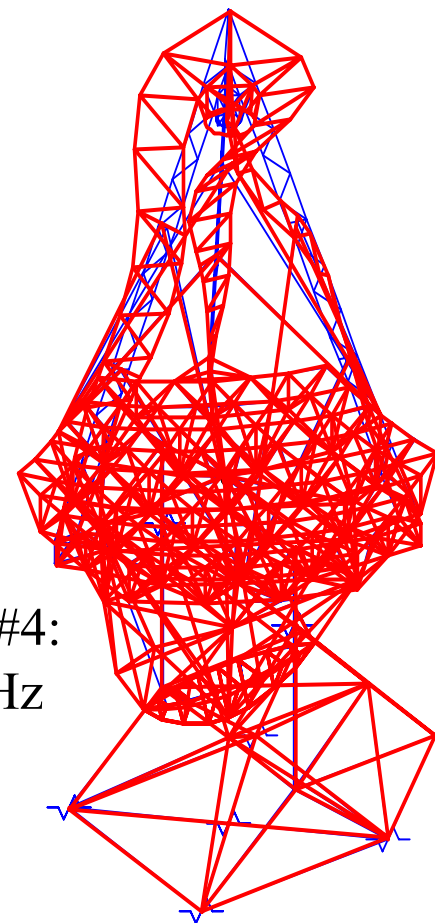
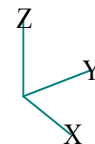

GSMT: OPD Zernike #2

AURA NEW INITIATIVES OFFICE

Tilt

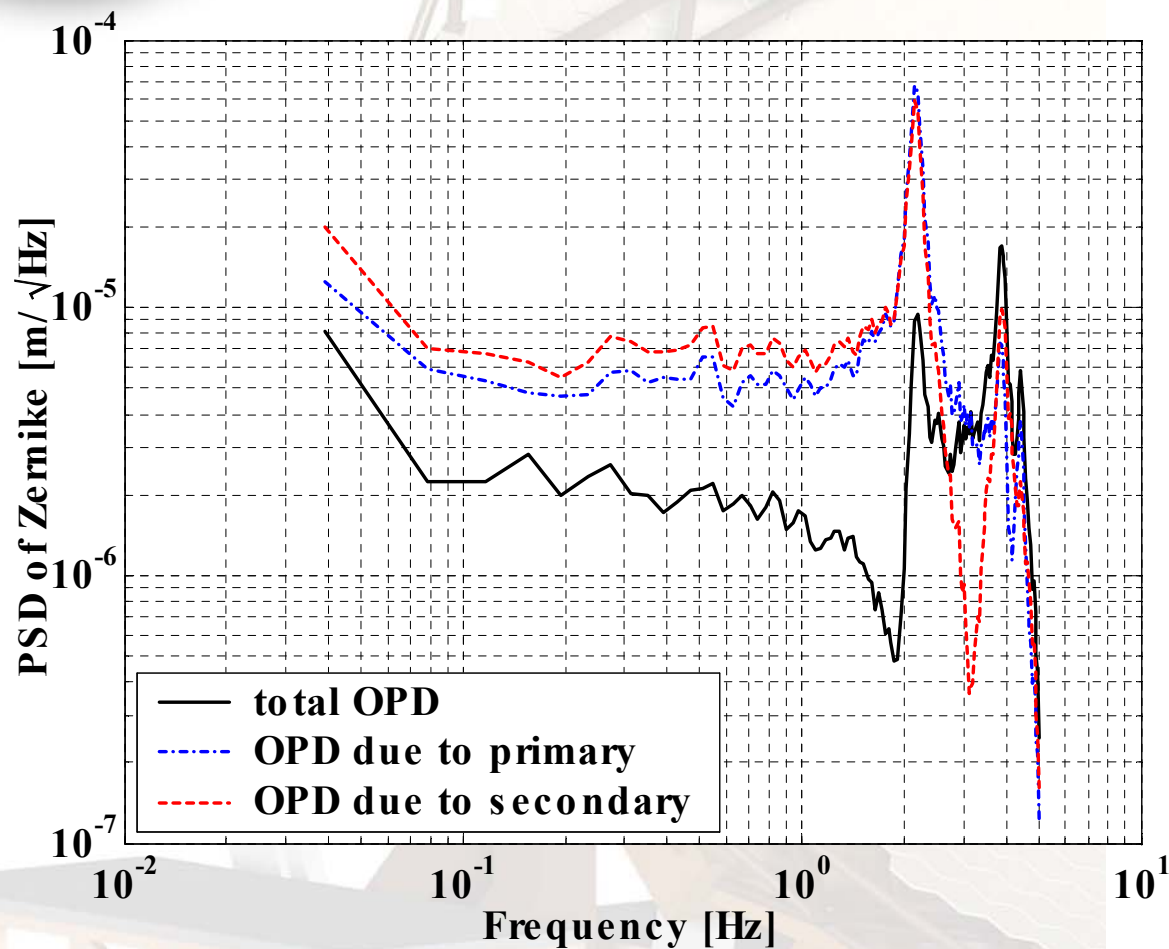

Mode #1:
2.17 Hz

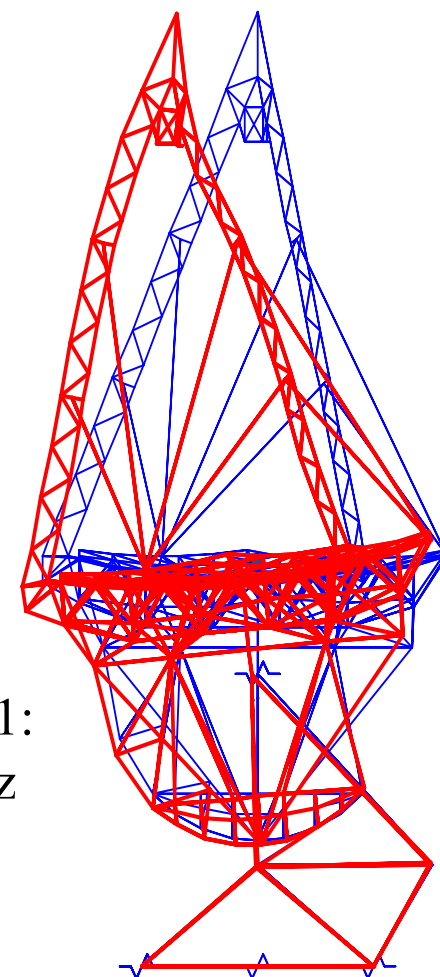
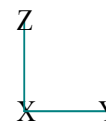

Interface to ray tracing

AURA NEW INITIATIVES OFFICE

- **Why OSLO?**
 - Former experience (Brooke)
 - Compiled, C like language (ccl) available for development
 - DLL capability for high speed
 - Linux version coming
- **Interface**
 - Self contained (object like) optical block
 - Deformation passed from Matlab to OSLO
 - Custom ray trace written in ccl or DLL
 - OPD calculated in OSLO and read back to Matlab
 - Currently through DDE



Gemini Imaginary Segmented Mirror Testbed

AURA NEW INITIATIVES OFFICE

- **“Segmented” Gemini mirror**
 - Segment size 1.152 m edge-to-edge
 - Actuator stiffness 10 N/ μm
 - No dynamics

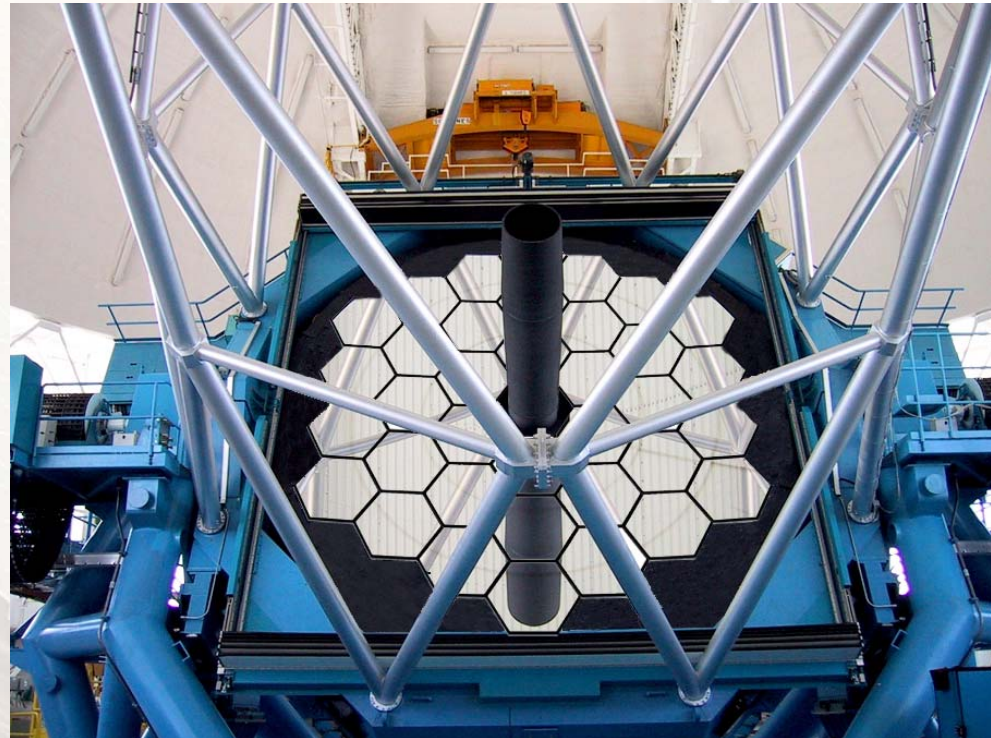

GISMT continuity and shape control

AURA NEW INITIATIVES OFFICE

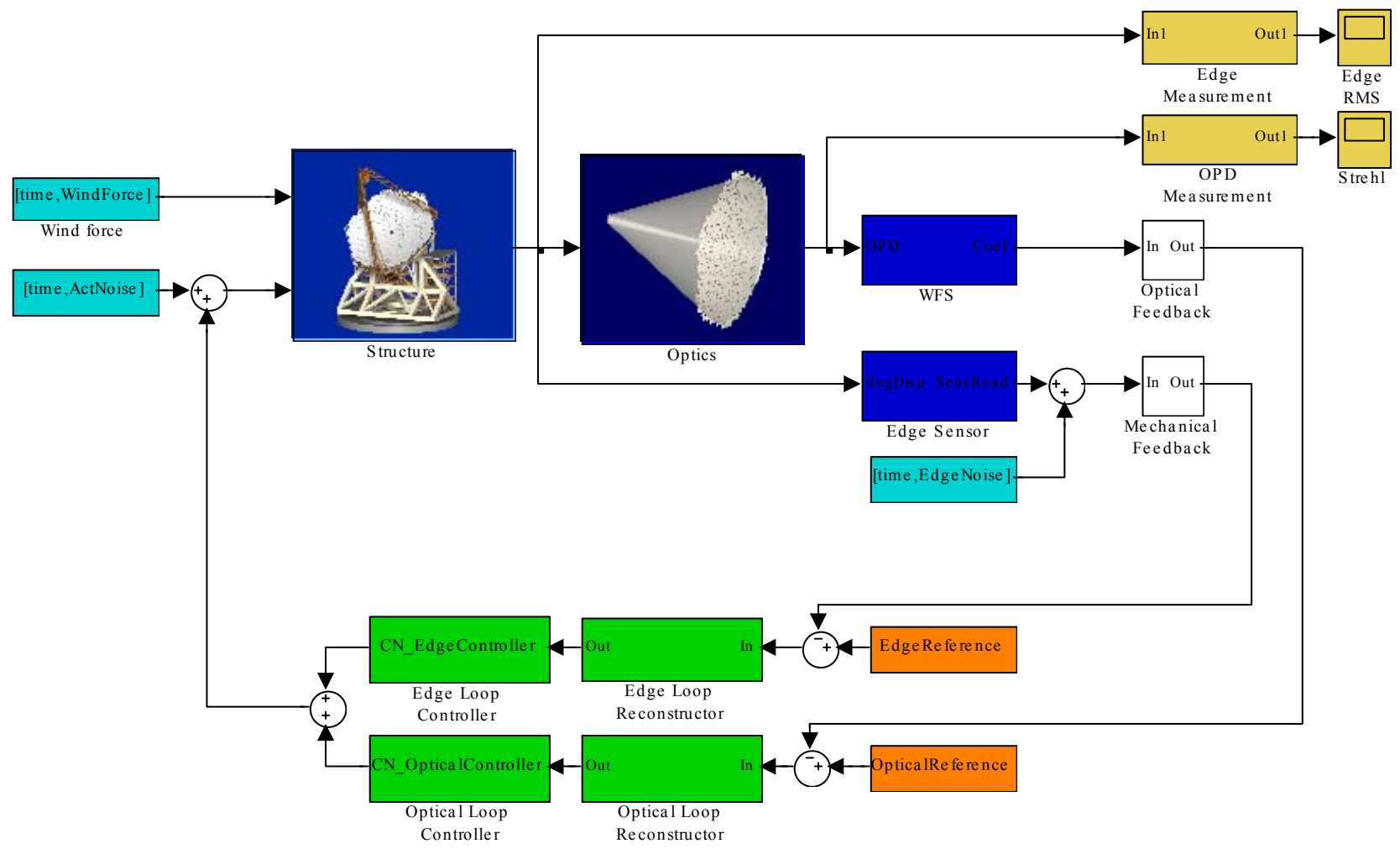

GISMT primary mirror

AURA NEW INITIATIVES OFFICE

$A_{\text{optical}}=20$
 $BW_{\text{optical}}=0.05 \text{ Hz}$

$A_{\text{edge}}=20$
 $BW_{\text{edge}}=0.1 \text{ Hz}$

Wind: c00030oo

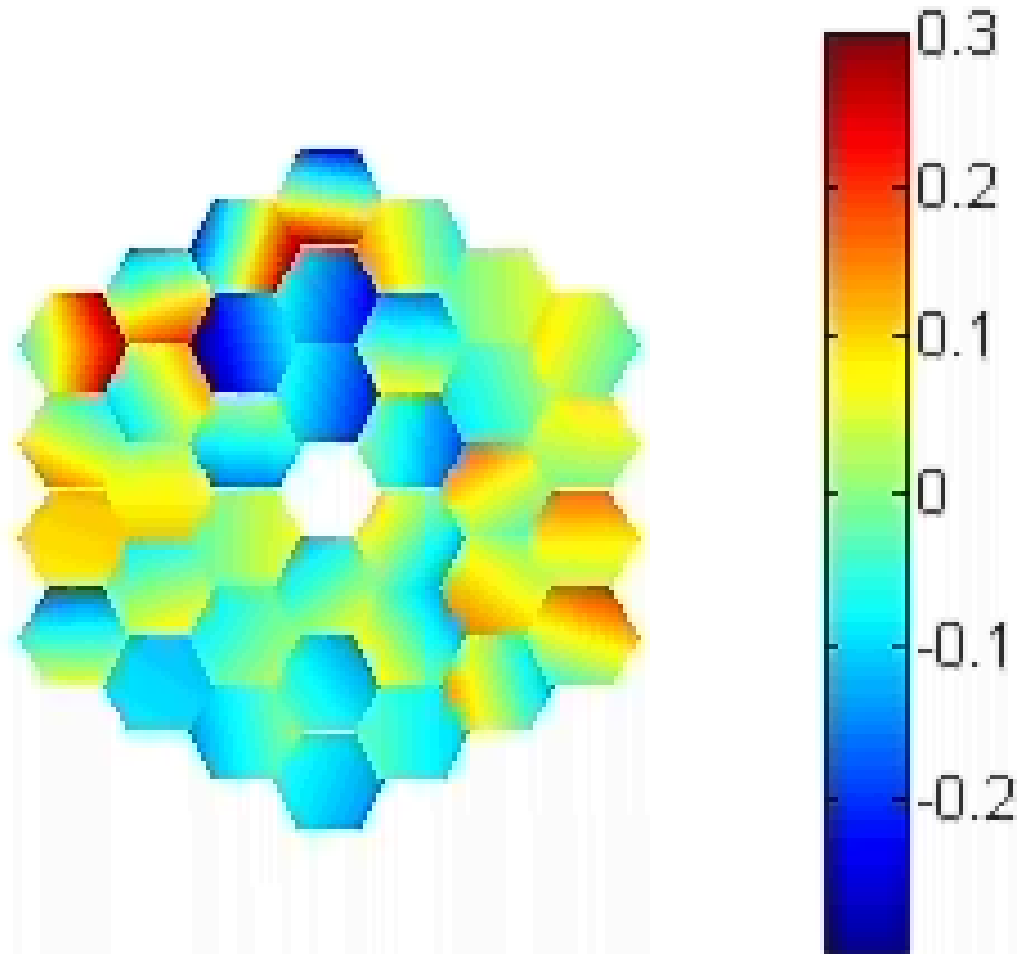

GISMT primary mirror continuity

AURA NEW INITIATIVES OFFICE

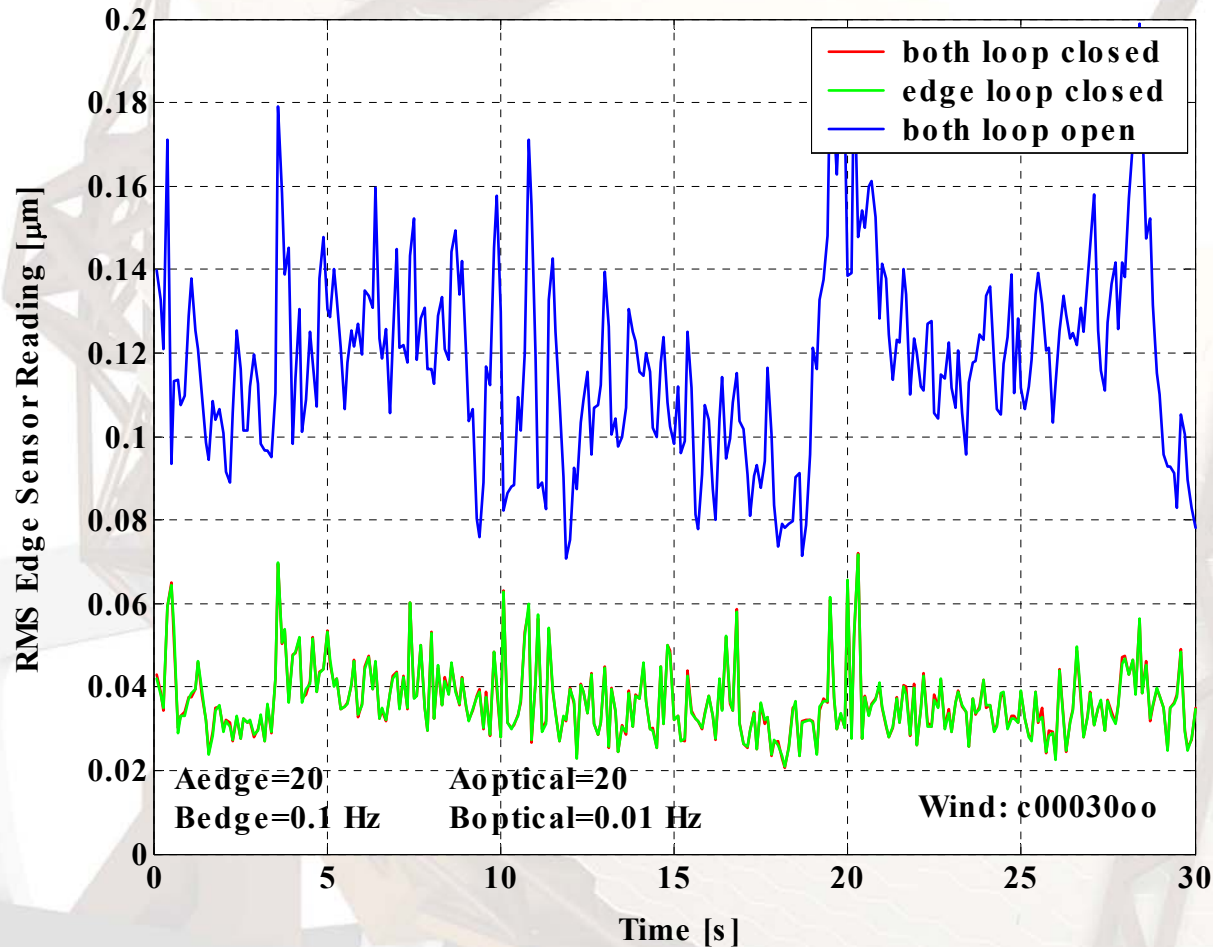

GISMT optical quality

AURA NEW INITIATIVES OFFICE

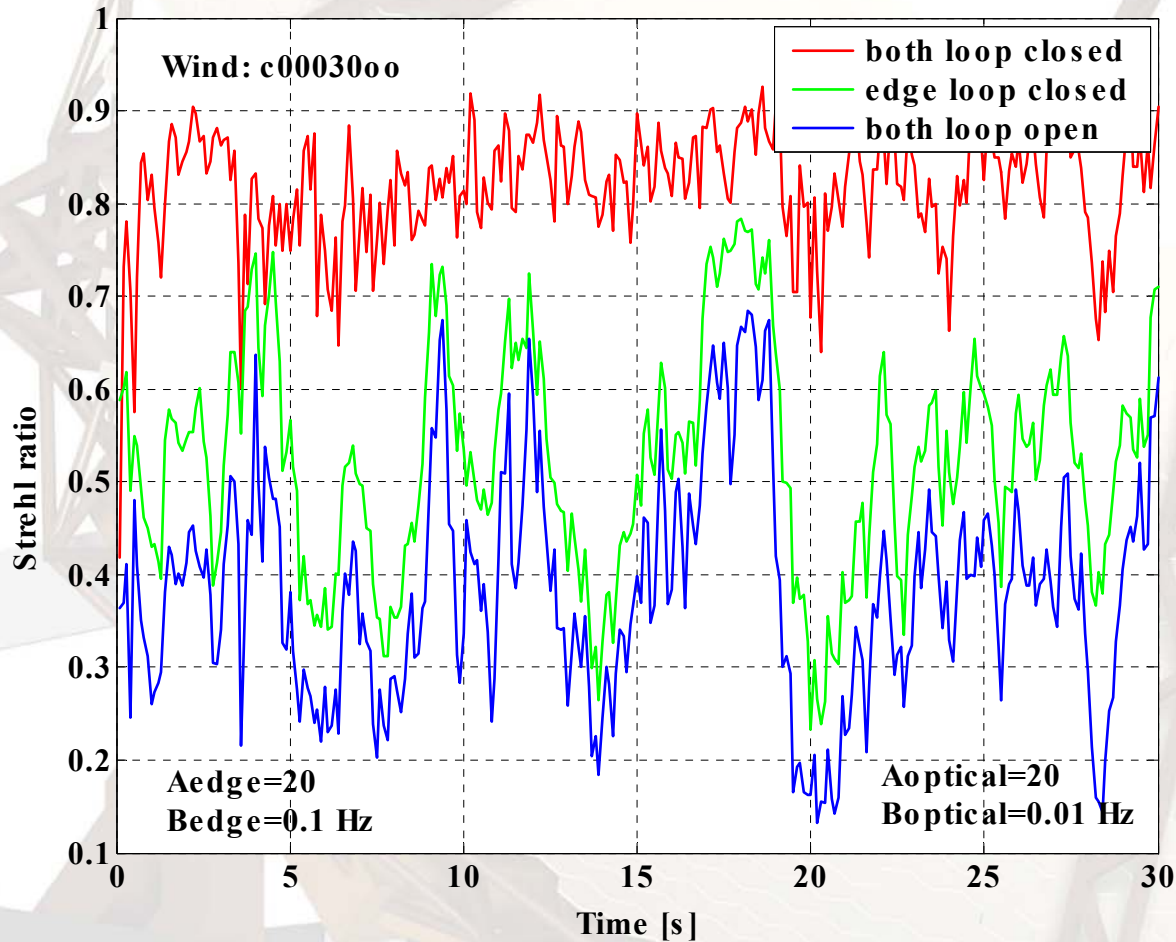

Next steps

AURA NEW INITIATIVES OFFICE

- Fully develop the **linear wind model**
- Install the **cluster** to
 - Improve ray tracing
 - Allow parallel structural dynamics and ray tracing
- Incorporate GISMT structural dynamics and introduce the third control loop (secondary rigid body)
- **Optimize** control laws
- Integrate with AO simulation (“independent” telescope)



Linear optical model (cont.)

AURA NEW INITIATIVES OFFICE

$$\varepsilon(\rho, \varphi) = \sum_{i=0}^{\infty} \mathbf{a}_i \mathbf{z}_i(\rho, \varphi)$$

$$\boldsymbol{\varepsilon} = [\mathbf{z}_0 \quad \mathbf{z}_1 \quad \cdots \quad \mathbf{z}_N] \mathbf{a} = \mathbf{Z} \mathbf{a}$$

$$\mathbf{d}_\rho = \mathbf{Z}_\rho \mathbf{b}_\rho$$

$$\mathbf{d}_\rho = \mathbf{P} \boldsymbol{\Phi}_\rho \mathbf{q}_m$$

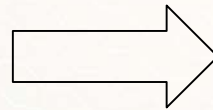

$$(\mathbf{Z}_\rho^T \mathbf{Z}_\rho) \mathbf{b}_\rho = \mathbf{Z}_\rho^T \mathbf{P} \boldsymbol{\Phi}_\rho \mathbf{q}_m$$

$$(\mathbf{Z}_\rho^T \mathbf{Z}_\rho) = \mathbf{I}$$



$$\mathbf{b}_\rho = \mathbf{Z}_\rho^T \mathbf{P} \boldsymbol{\Phi}_\rho \mathbf{q}_m$$

$$\mathbf{a}_{\text{system}} = \mathbf{a}_{\text{atmosphere}} + \mathbf{S}_\rho \mathbf{b}_\rho + \mathbf{S}_s \mathbf{b}_s \quad (+ \mathbf{a}_{\text{telescope}})$$



GSMT: OPD Zernike #6

AURA NEW INITIATIVES OFFICE

Coma

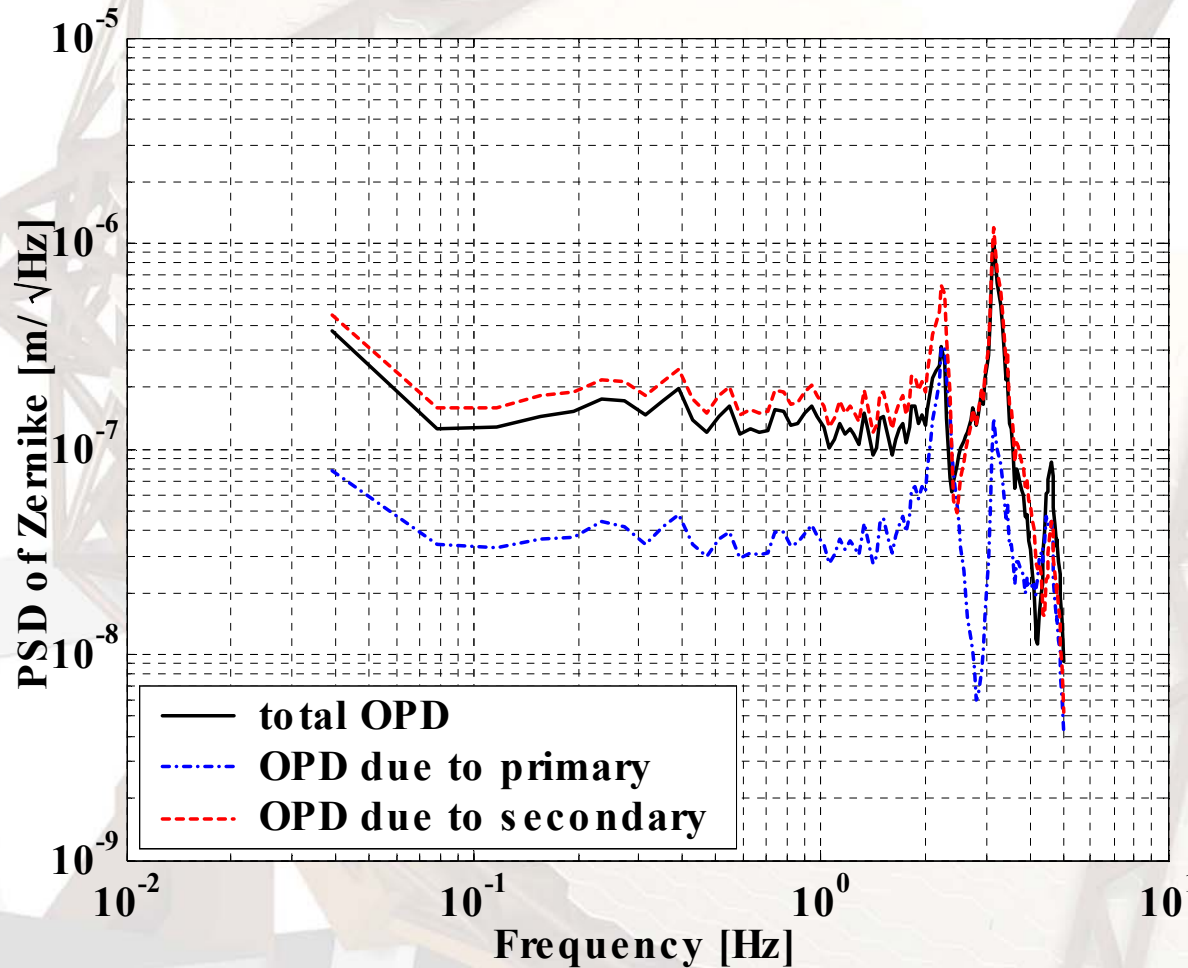

Modeling approaches

AURA NEW INITIATIVES OFFICE

- **Design model (linear)**
 - Understand the underlying physics
 - Compare design approaches
 - Specify and design sensors, actuators and control laws
 - Run analyses (disturbance, sensitivity, uncertainty, isoperformance)
 - Optimization
- **Verification model (full, nonlinear)**
 - Derive and verify design models
 - Estimate the validity regions of linear models
 - Verify telescope design (structural, optical and control)
 - Estimate telescope performance

