

THIS DOCUMENT CONTAINS INFORMATION PROPRIETARY TO WESTERN GEAR CORPORATION. ALL DESIGN, MANUFACTURING, REPRODUCTION, USE, PATENT, AND SALES RIGHTS REGARDING THE SAME ARE HEREBY EXPRESSLY RESERVED BY WESTERN GEAR CORPORATION. THIS DOCUMENT IS SUBMITTED FOR REFERENCE PURPOSES ONLY AND SHALL NOT BE DISCLOSED TO ANY UNAUTHORIZED PERSON OR INCORPORATED INTO ANY OTHER PROJECT.

REVISIONS				
ZONE	LTR	DESCRIPTION	DATE	APPROVED
	A	REVISED PER AURA REQ	1-10-70	WJL
	B	CORRECTIONS NOTED & ADDED PER AURA REQ	2-26-70	

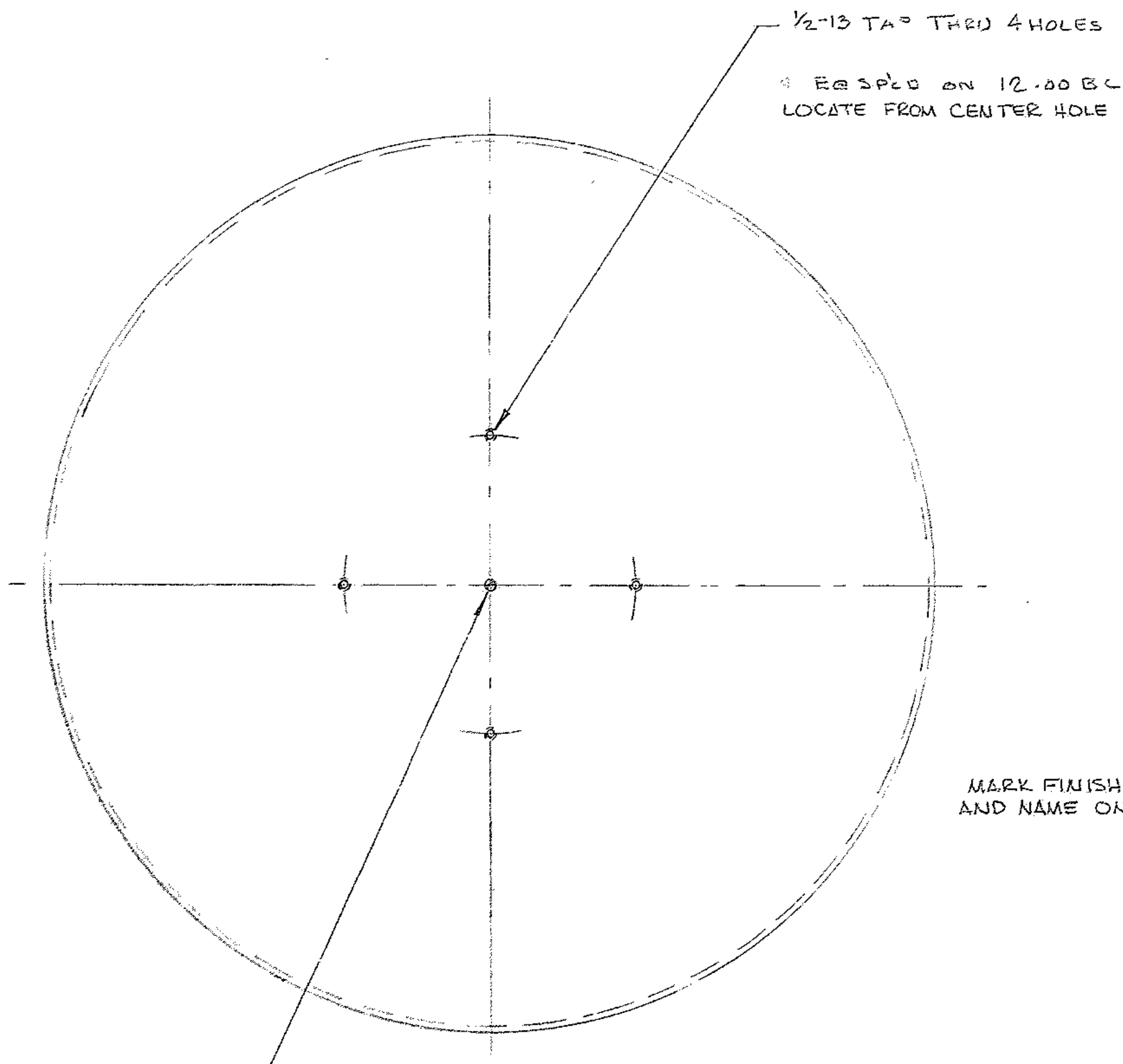

1/16" DRILL FOR VENT, CENTER WITHIN .010.
 AFTER MACHINING, MIRROR, BORE .500/.502 DIA
 CENTERED TO O.D. WITHIN .005 T.I.R.,

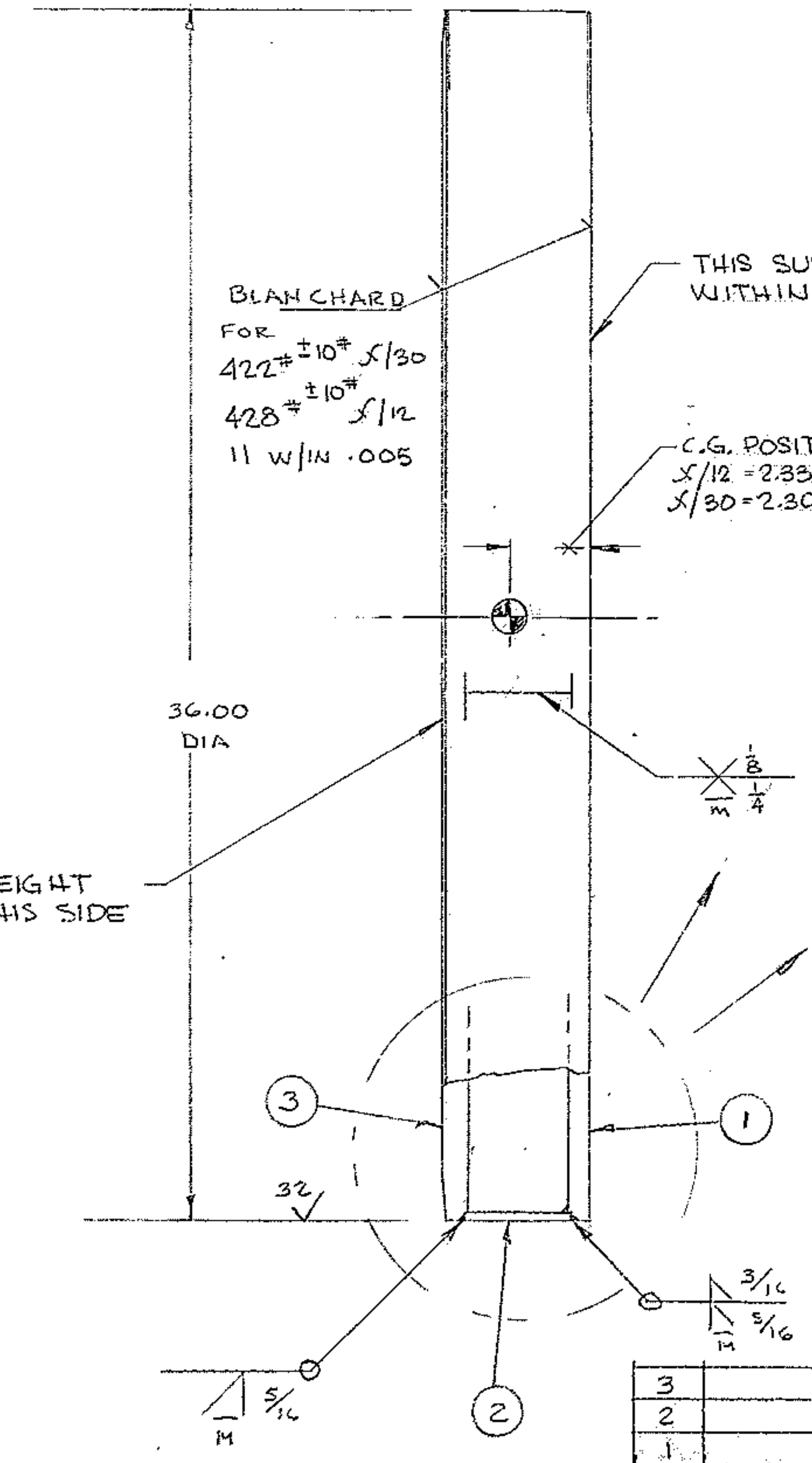

MARK FINISH WEIGHT AND NAME ON THIS SIDE

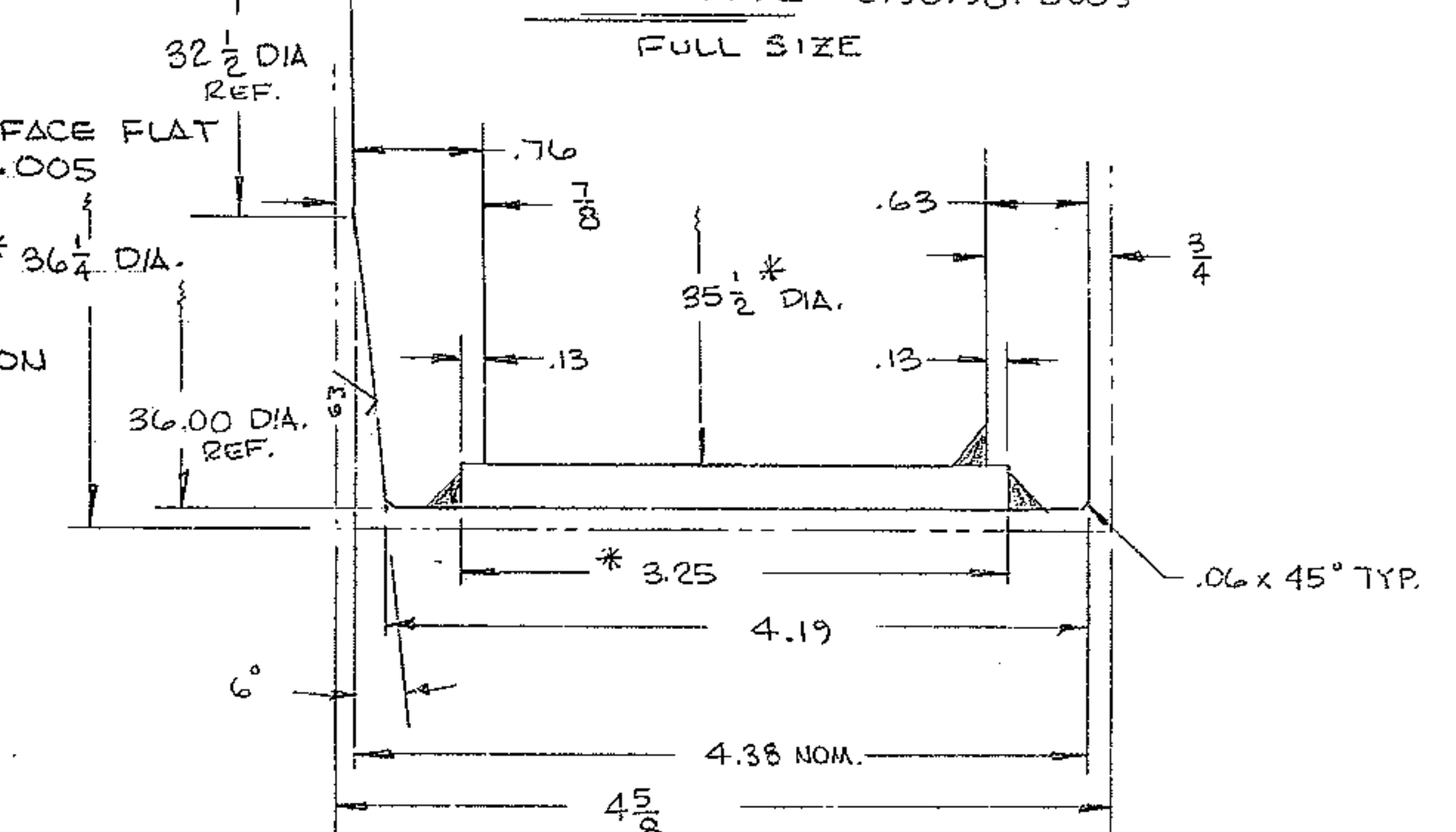
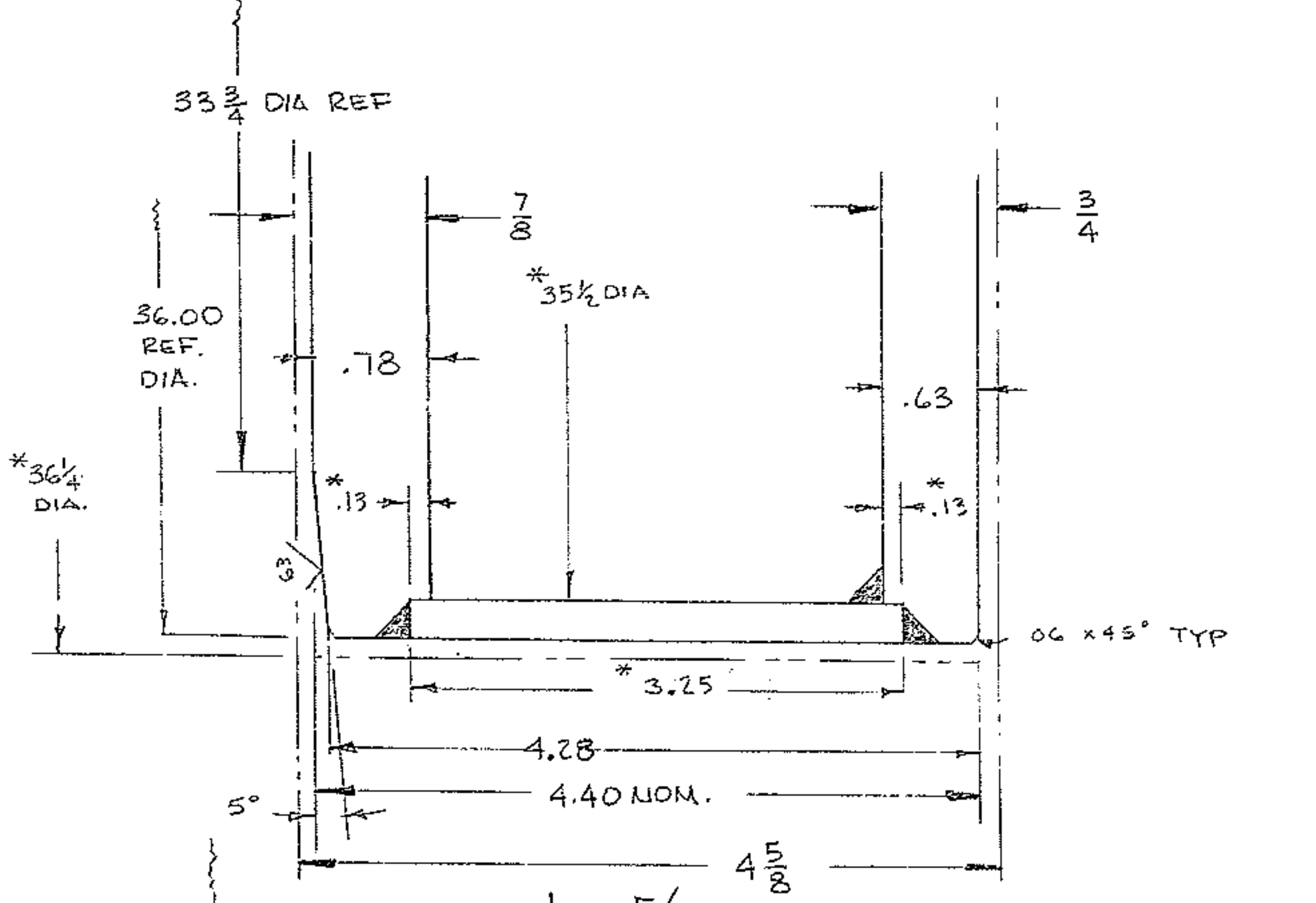

- NOTE:
 * 1. PREMACHINE MAT'L TO DIMS MARKED *
 2. WELD & STRESS RELIEVE
 3. MACHINE & BLANCHARD GRIND
 4. PARKERIZE

REF. 1199

REF. 1200

FIND. NO.	PART. NO.	DESCRIPTION	QTY	MATERIAL	CODE IDENT
3		36 1/4 DIA X 7/8 R	2	C-1020 HR STL	
2		3/8 X 3 1/2 BAR	2	C-1020 HR STL	
1		36 1/2 DIA X 3/4 R	2	C-1020 HR STL	

LIST OF MATERIAL (LM)

LIMITS ON MACHINED DIMENSIONS EXCEPT AS NOTED ANGULAR AS NOTED LINEAR: X = ±.1, .XXX = ±.010, .003 .XX = ±.001 FRACTIONAL = ±1/32 BREAK ALL SHARP EDGES		150" STELLAR TELESCOPE		HEAVY MACHINERY DIVISION EVERETT, WASHINGTON	
DRAWN WJR 4-25-69 CHECK WJR 1-12-70 ENGR DE 1-12-70		WESTERN GEAR CORPORATION		X/12 DUMMY MIRROR AND X/30 DUMMY MIRROR	
MATERIAL NOTED		APPROVED		X/12 CELL AND SUPPORT ASSY X/30 CELL AND SUPPORT ASSY	
SIZE CODE IDENT NO. D 16603		2150.581 D003 (-1)		REV B	
SCALE 1/2" = 1" (AS NOTED)		WT NOTED		LB SHEET OF	

N/A 2150.581 E002 - X/12
 N/A 2150.582 E002 - X/30
 (2) TOTAL / 1EA.