

THIS DOCUMENT CONTAINS INFORMATION PROPRIETARY TO WESTERN GEAR CORPORATION. ALL DESIGN, MANUFACTURING, REPRODUCTION, USE, PATENT, AND SALES RIGHTS REGARDING THE SAME ARE HEREBY EXPRESSLY RESERVED BY WESTERN GEAR CORPORATION. THIS DOCUMENT IS SUBMITTED FOR REFERENCE PURPOSES ONLY AND SHALL NOT BE DISCLOSED TO ANY UNAUTHORIZED PERSON OR INCORPORATED INTO ANY OTHER PROJECT.

REVISIONS				
ZONE	LTR	DESCRIPTION	DATE	APPROVED
A	AS BUILT		2289 M.C.	7-20-71 JLB

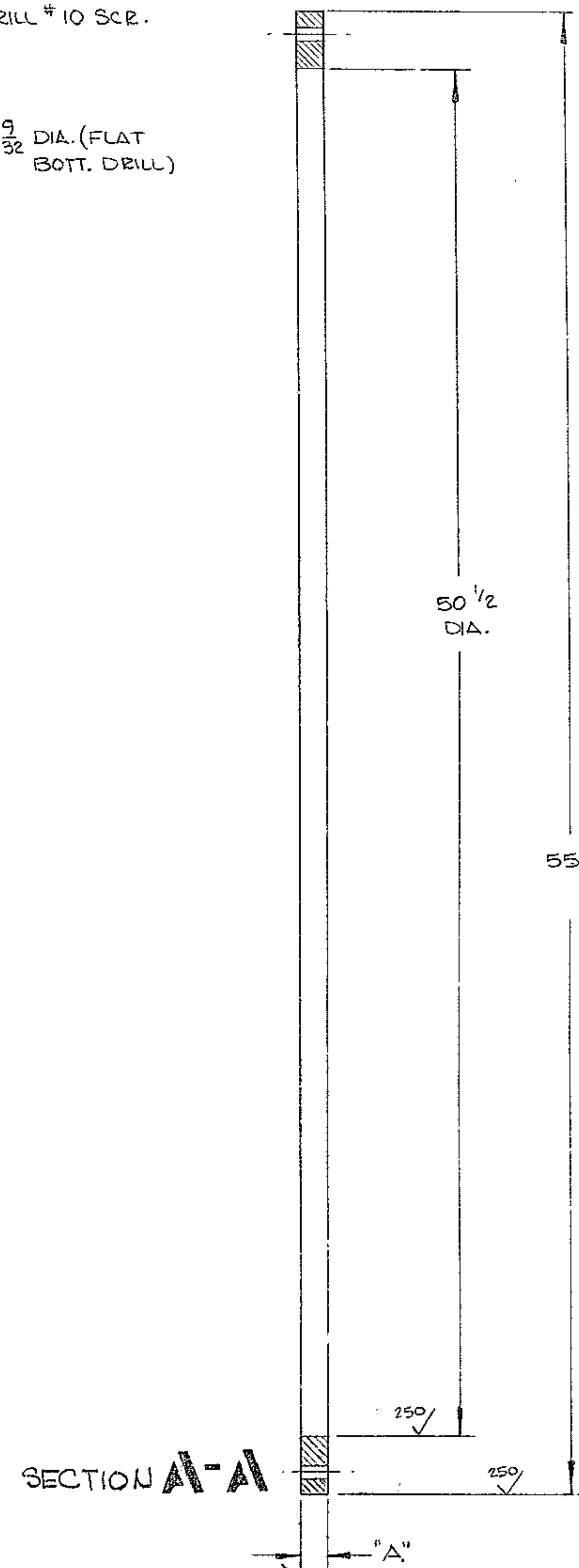
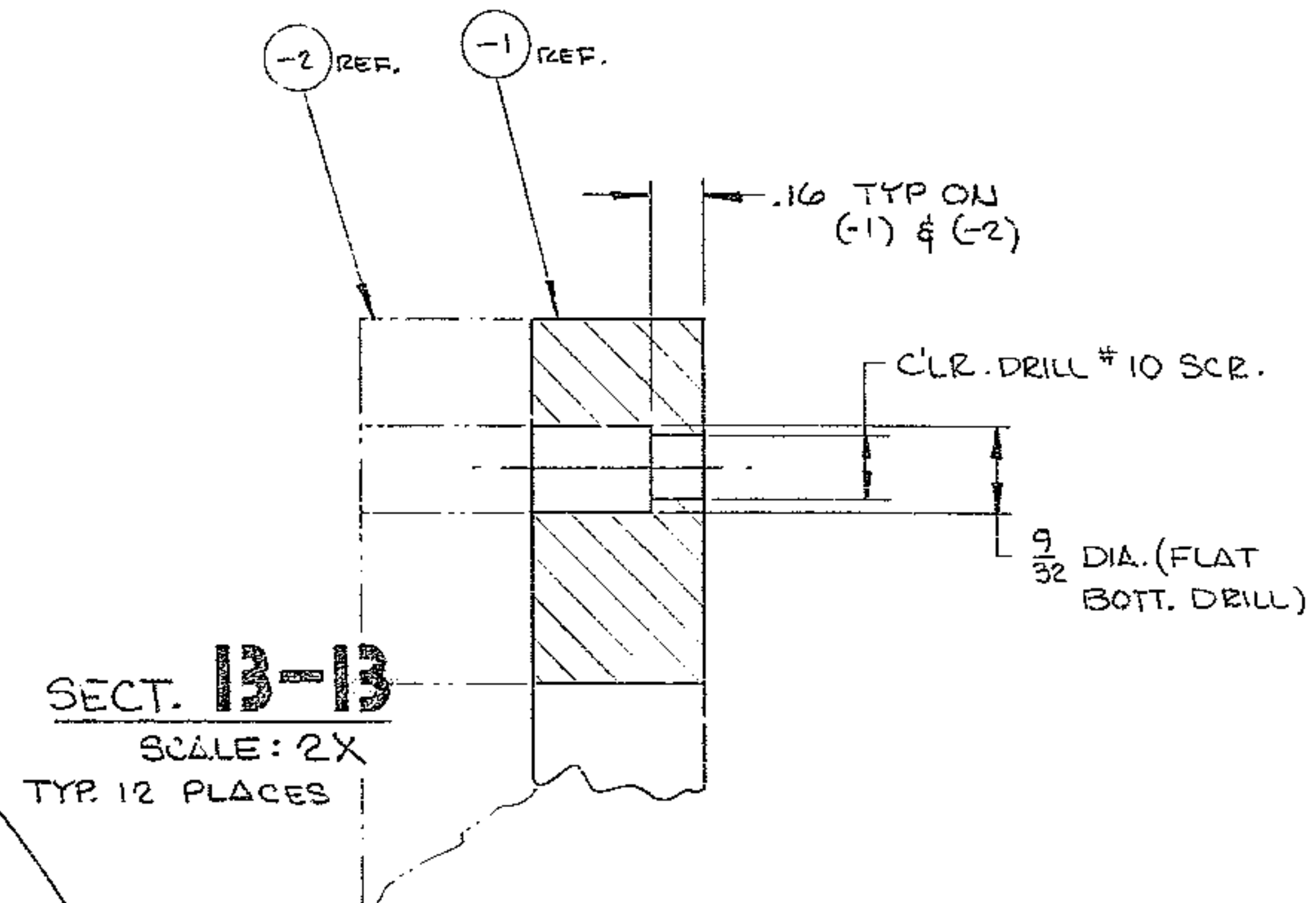
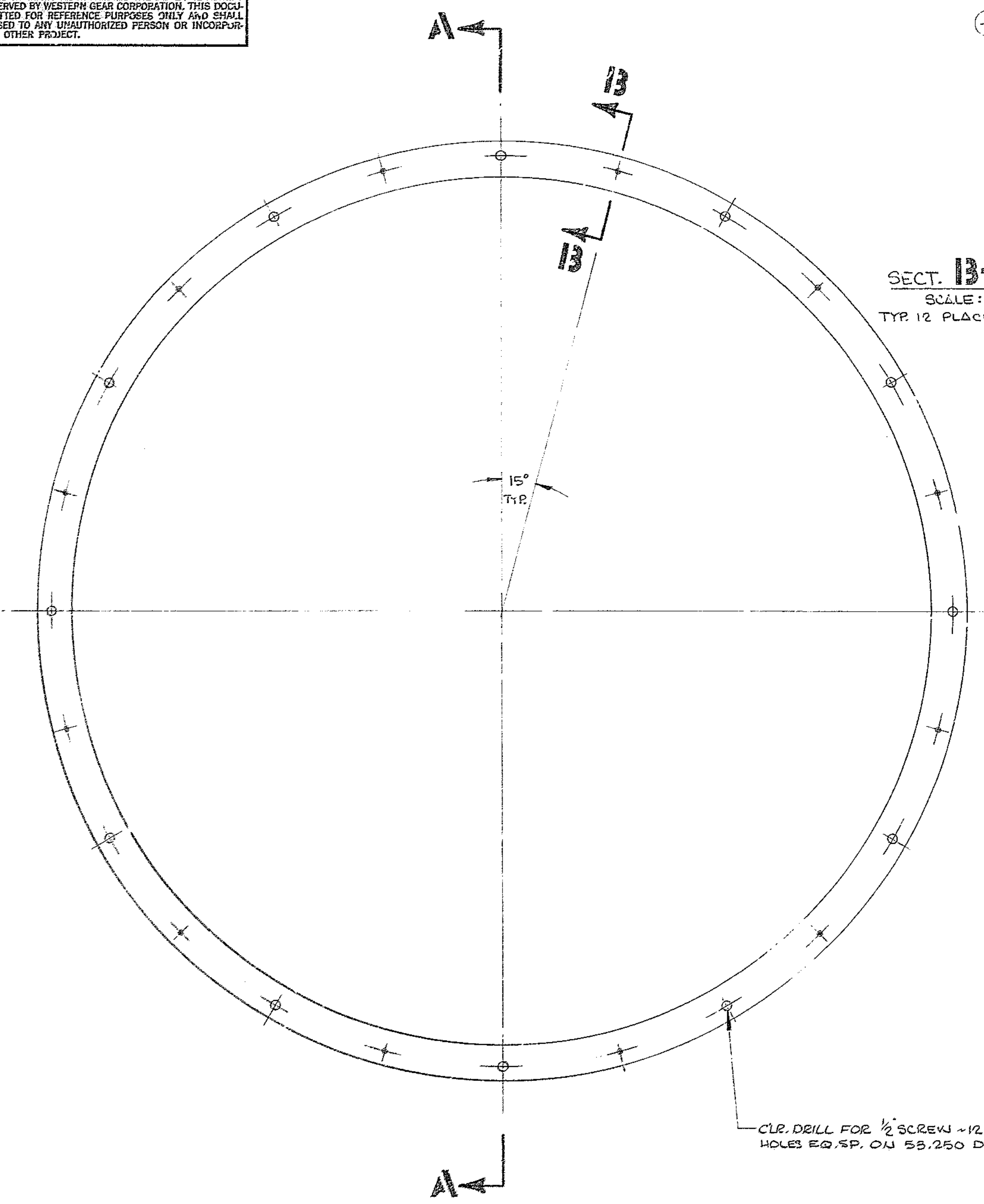

DASH	PART NO.	"A" DIM	REQ.	
-1	2150.580D018	.50	1	STANDARD SPACER
-2	2150.580D019	1.00	1	LONG SPACER

1. NOTE THIS PART IS TO BE SUPPLIED LOOSE WITH FINAL ASSEMBLY 2150.501E002 FOR FUTURE FOCAL ADJUSTMENT BY AURA

REF 1198

SEE NOTE 1.  
N/A-2150.580E002  
(1) 2150.580D018 REQ.  
(1) 2150.580D019 REQ.

FIND NO.	PART NO.	DESCRIPTION	QTY	MATERIAL	CODE IDENT
LIST OF MATERIAL (LM)					
LIMITS ON MACHINED DIMENSIONS EXCEPT AS NOTED		150" STELLAR TELESCOPE		 HEAVY MACHINERY DIVISION EVERETT, WASHINGTON  <b>FOCUS POSITION SPACER</b> <b>1/8" MIRROR CELL &amp; SUPPORT ASSY</b>	
ANGULAR = ± 1/2°		DRAWN R. CHAVEZ 3-13-70			
LINEAR: X = ± .1 XXX = ± .001 .003 XX = ± .001 FRACTIONAL = ± 1/32		CHECK WIE 3-16-70			
BREAK ALL SHARP EDGES		ENGR [Signature] 3-17-70			
MATERIAL		2024-T4 ALUM.			
FINISH - BLACK ANODIZE		1 (1) REQ. PER N/A			
		1 (2) REQ. PER N/A			
APPROVED					
SIZE		CODE IDENT NO.			
D 16603		2150.580D018 (1)		REV A	
SCALE 1/4"		WT 18.4		LB SHEET 1 OF 1	