

REVISIONS				
ZONE	LTR	DESCRIPTION	DATE	APPROVED
A		REVISED / AURA COHEN PRINT	2-27-74	W.R.
B		AS BUILT 2288 C.S.	7/7/77	JLB

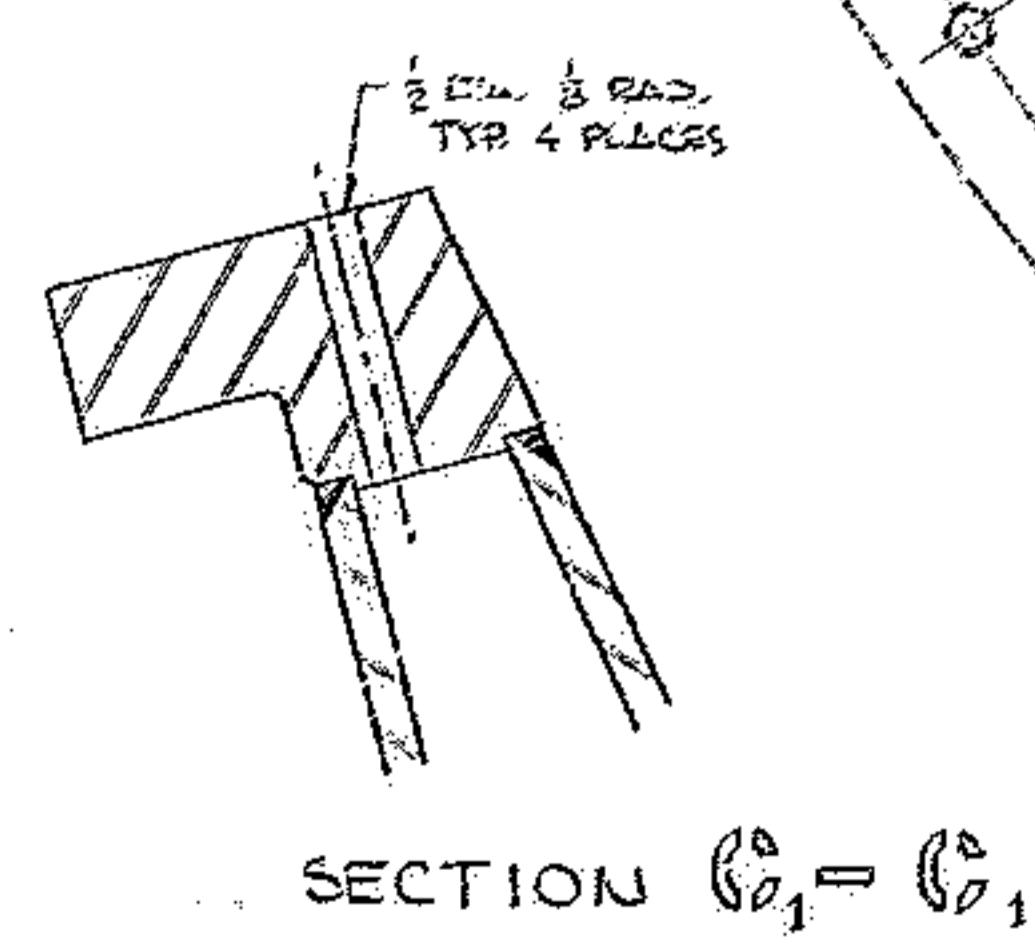
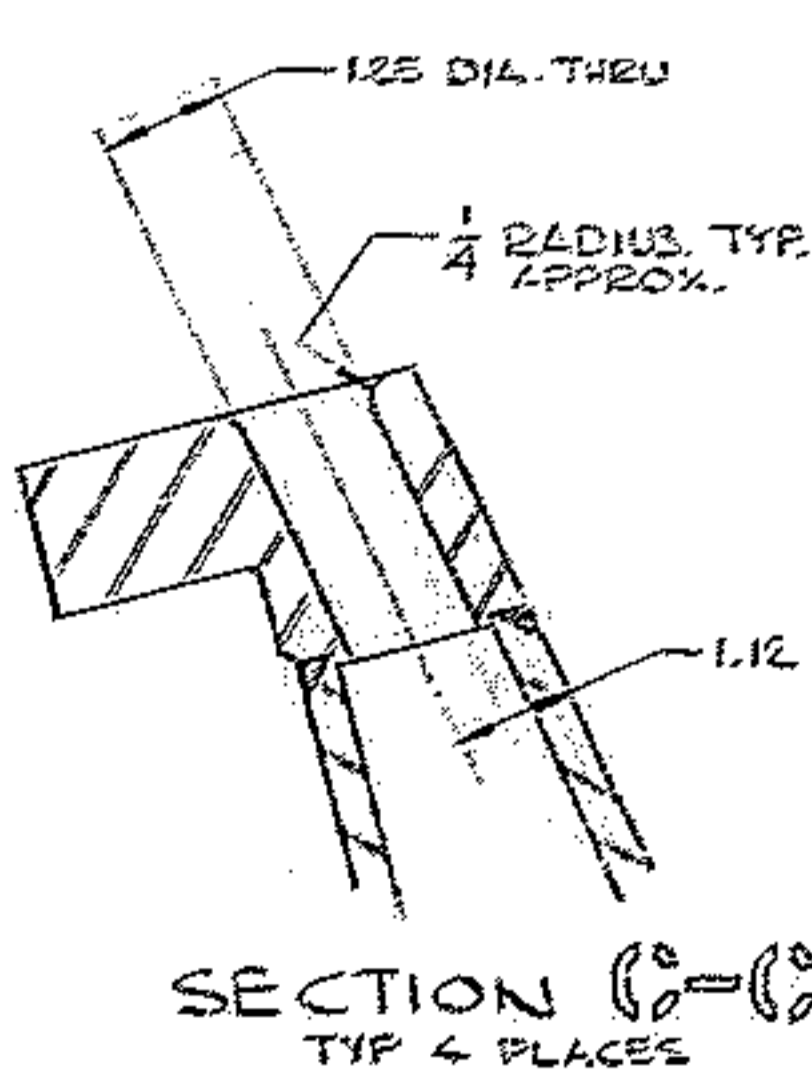
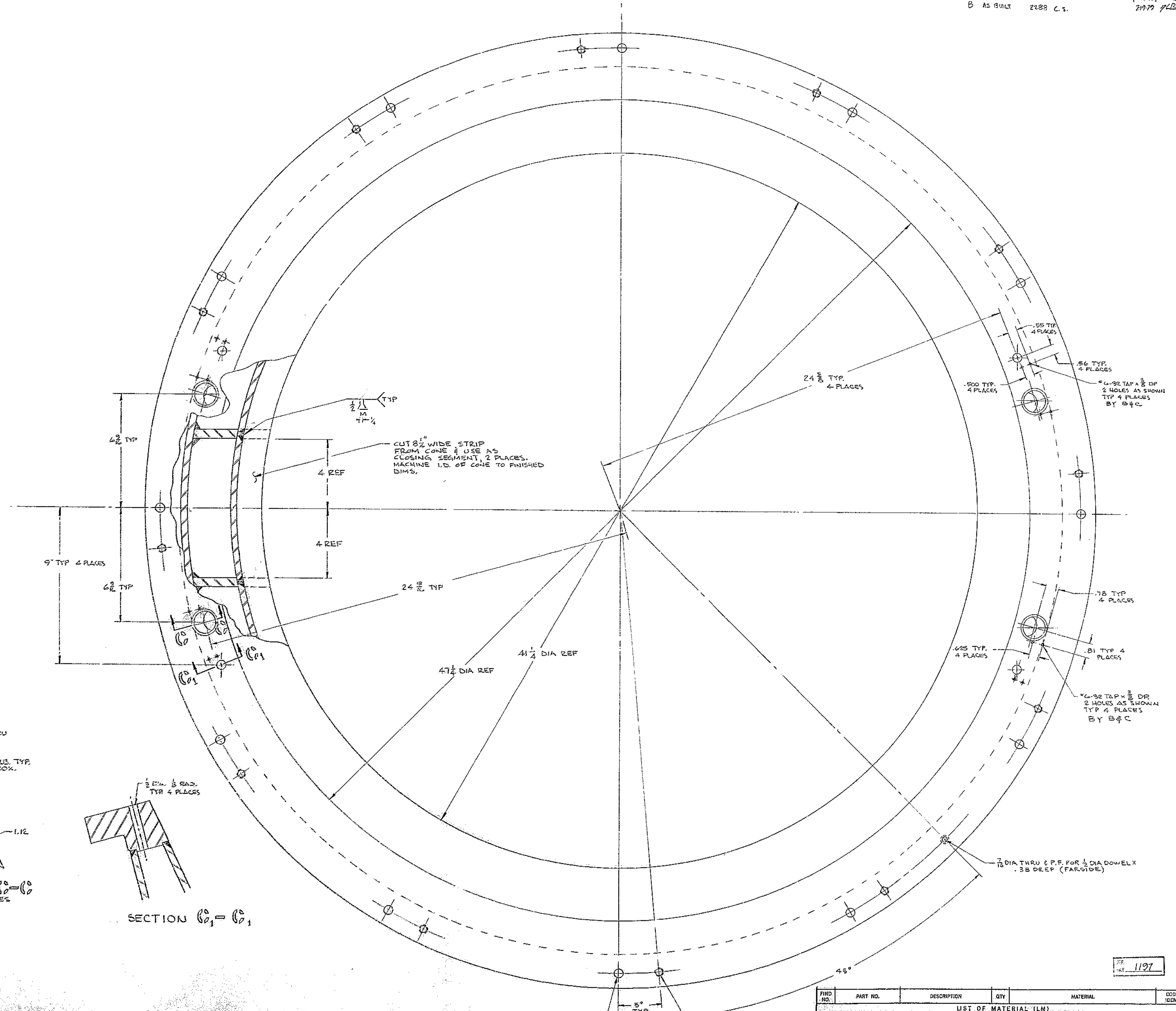

VIEW 13-13

TAP 1/2-13 THRU 12 HOLES EQ. SP. ON A 53 1/2 DIA. B.C. (FOR JACKING SCREWS & HANDLING) BY B&C

CLD DRILL FOR 1/2 SCR 12 HOLES EQ. SP. ON A 53.250 DIA. B.C. BY B&C

FIG. NO.	PART NO.	DESCRIPTION	QTY	MATERIAL	CODE IDENT									
LIST OF MATERIAL (LM)														
LIMITS ON MACHINED DIMENSIONS EXCEPT AS NOTED														
ANGULAR = ± 100'														
LINEAR: .XX = ± .001														
.XX = ± .001														
.XXX = ± .0005														
.XXX = ± .001 FRACTIONAL = ± 1/22														
B&C														
BREAK ALL SHARP EDGES														
MATERIAL														
<table border="1"> <tr> <td>DRAWN</td> <td>C. JACKSON</td> <td>5-31-69</td> </tr> <tr> <td>CHECK</td> <td>W.R.</td> <td>5-10-70</td> </tr> <tr> <td>ENGR</td> <td>JLB</td> <td>2-11-70</td> </tr> </table>						DRAWN	C. JACKSON	5-31-69	CHECK	W.R.	5-10-70	ENGR	JLB	2-11-70
DRAWN	C. JACKSON	5-31-69												
CHECK	W.R.	5-10-70												
ENGR	JLB	2-11-70												
<table border="1"> <tr> <td>SIZE</td> <td>CODE IDENT NO.</td> <td>REV</td> </tr> <tr> <td>E 16603</td> <td>2150.570 E004</td> <td>B</td> </tr> </table>						SIZE	CODE IDENT NO.	REV	E 16603	2150.570 E004	B			
SIZE	CODE IDENT NO.	REV												
E 16603	2150.570 E004	B												
SCALE: HALF WT LB SHEET 2 OF 2														