

THIS DOCUMENT CONTAINS INFORMATION PROPRIETARY TO WESTERN GEAR CORPORATION. ALL DESIGN, MANUFACTURING, REPRODUCTION, USE, PATENT AND SALES RIGHTS REGARDING THE SAME ARE HEREBY EXPRESSLY RESERVED BY WESTERN GEAR CORPORATION. THIS DOCUMENT IS SUBMITTED FOR REFERENCE PURPOSES ONLY AND SHALL NOT BE DISCLOSED TO ANY UNAUTHORIZED PERSON OR INCORPORATED INTO ANY OTHER PROJECT.

REVISIONS				
ZONE	LTR	DESCRIPTION	DATE	APPROVED
	A	INITIAL RELEASE	10-DEC-69	<i>[Signature]</i>

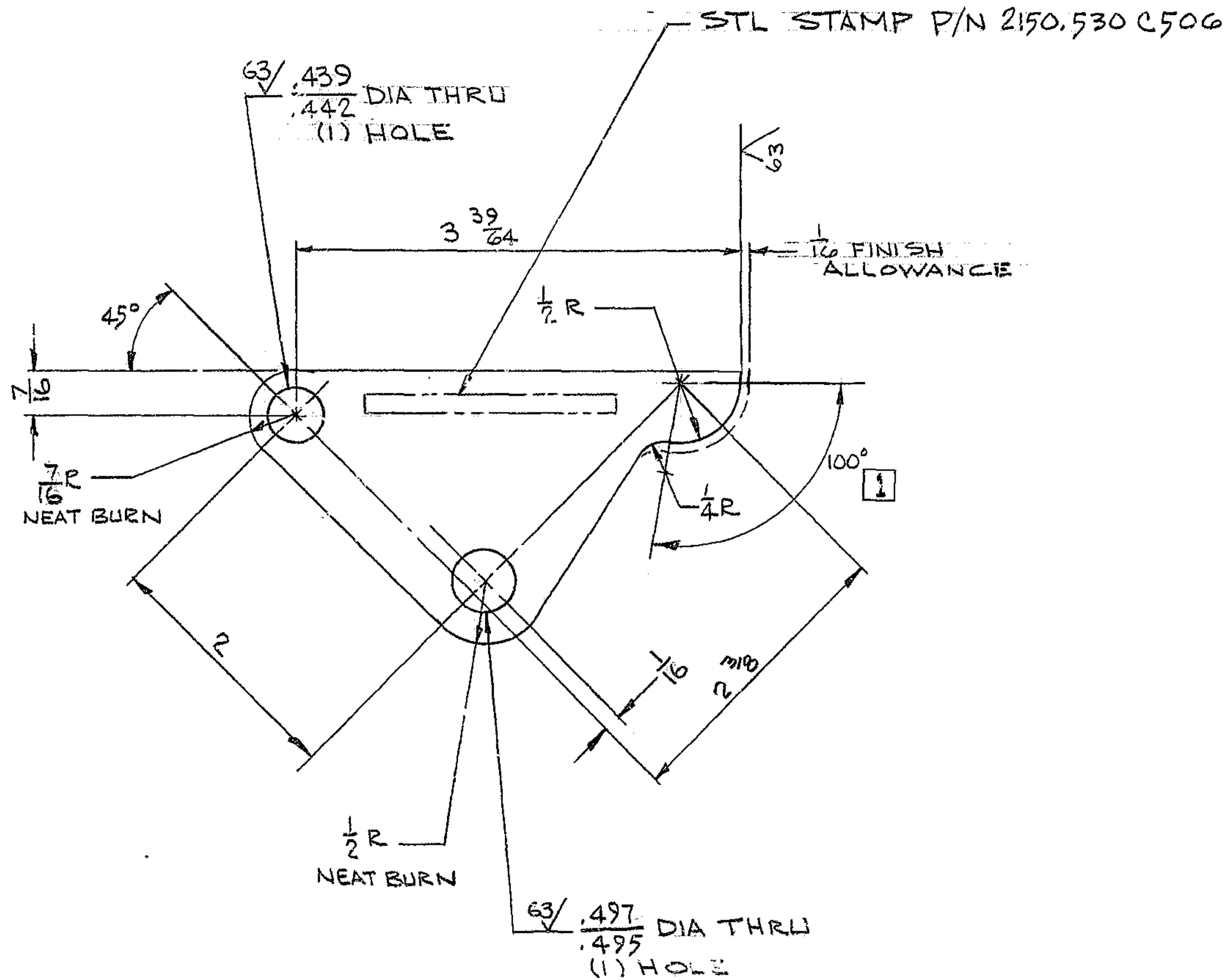

NOTES:

- CASE HARDEN $63\sqrt$ SURFACE TO 45 R_c MIN; .020 MIN FINISHED DEPTH.
- APPLY ONE COAT OF PRIME PAINT IMMEDIATELY AFTER CLEANING PER WGC SPEC NO. 511.

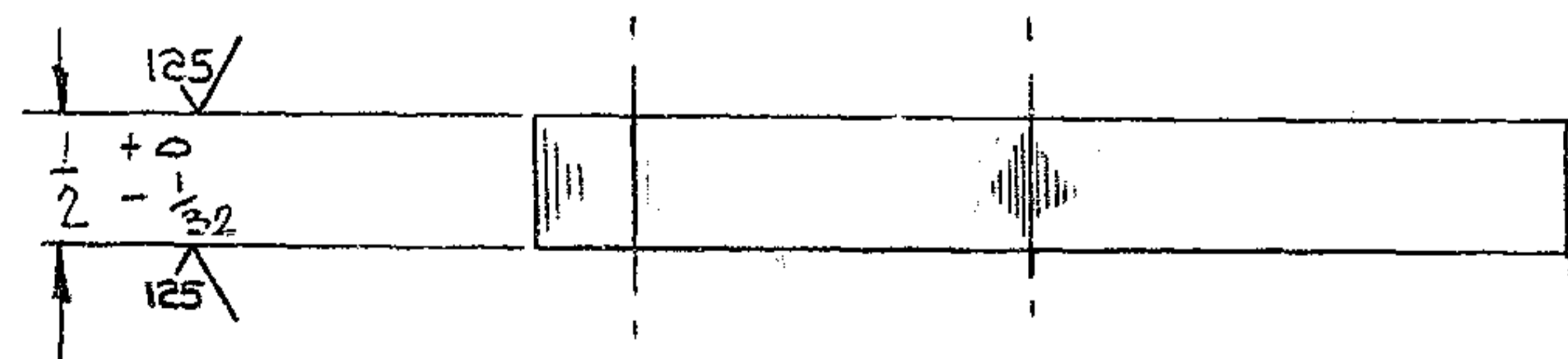

WESTERN GEAR CORPORATION
 CONSTRUCTION PROJECTS
 DEPARTMENT
 APPROVED FOR
 PROCUREMENT
G. P. [Signature] DATE 12/5/69

NEXT ASSY: 2150.530 D502 (WGD 300 293)

1193

FIND NO.	PART NO.	DESCRIPTION	QTY	MATERIAL	CODE IDENT
LIST OF MATERIAL (LM)					
LIMITS ON MACHINED DIMENSIONS EXCEPT AS NOTED ANGULAR = ± 1° 0'		150" STELLAR TELESCOPE MOUNTING		WESTERN HEAVY MACHINERY DIVISION GEAR CORPORATION EVERETT, WASHINGTON	
LINEAR: X = ± .1 .XXX = ± .010 .XX = ± .03 FRACTIONAL = ± 1/32		DRAWN SIBGREN 17 SEPT 69 CHECK <i>[Signature]</i> 30 SEP 69		<u>PLUNGER</u> SHOCK ABSORBER ASSY	
BREAK ALL SHARP EDGES		ENGR			
MATERIAL STEEL ASTM A-36 1/2 x 2 3/16 x 4 1/16		WGC 300 284		SIZE C	CODE IDENT NO. 2150.530 C 506
APPROVED				REV A	
SCALE 1/1		WT 1 LB		SHEET 1 OF 1	