

| REVISIONS |     |                             |         |          |
|-----------|-----|-----------------------------|---------|----------|
| ZONE      | LTR | DESCRIPTION                 | DATE    | APPROVED |
|           | A   | REVISED PER AURA APPD PRINT | 10/1/68 |          |

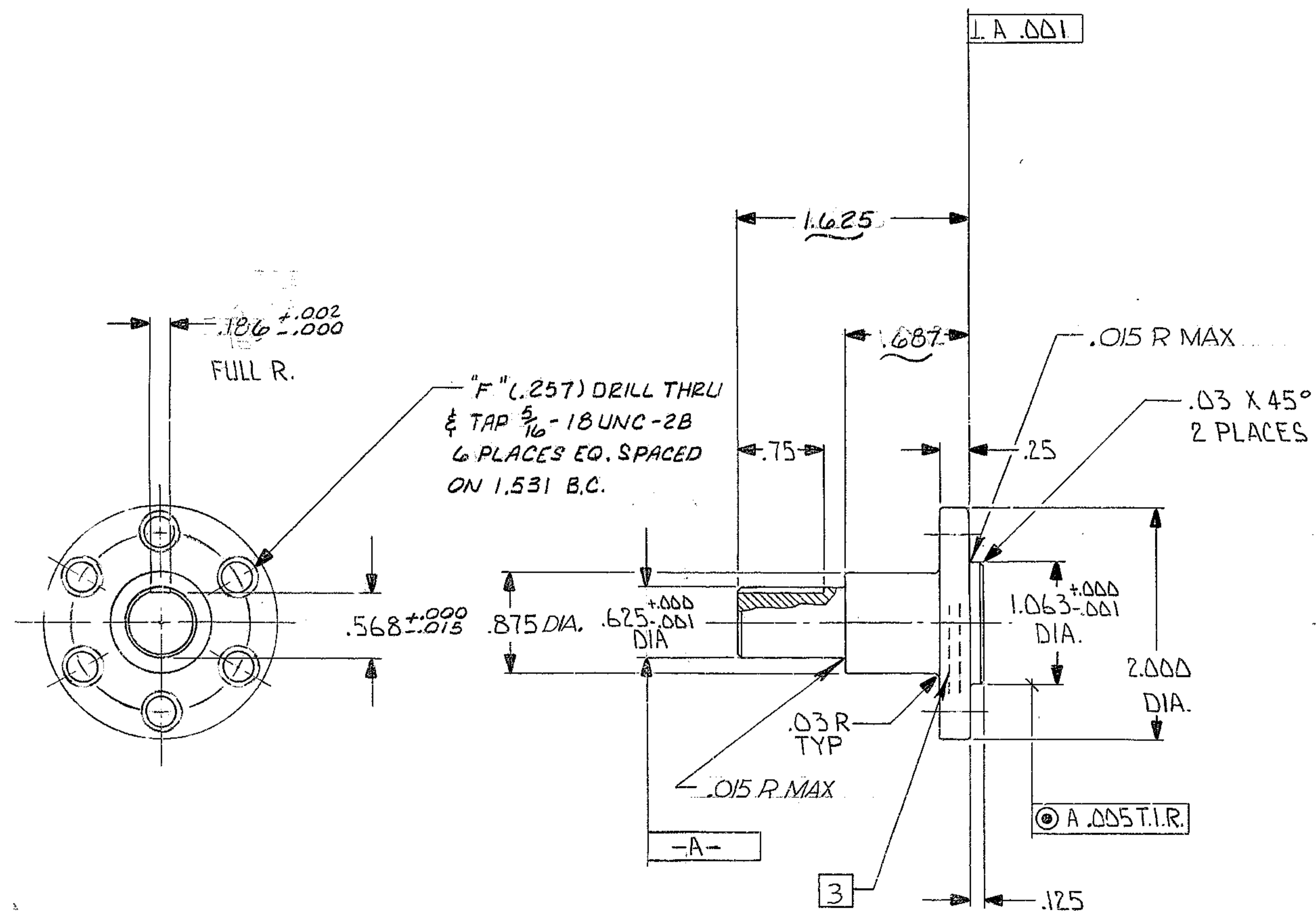

- NOTES:
1. ALL DIMENSIONS IN INCHES
  2. ALL SURFACES TO BE 125/ FINISH
  3. STAMP PART NO. "2150.530C106"
  4. CENTERS PERMISSABLE

NEXT ASSY : 2150.530E102 (WGN 102,939)

REF. FILE 1193

WESTERN GEAR CORPORATION  
 CONSTRUCTION PROJECTS  
 DEPARTMENT  
**APPROVED FOR  
 PROCUREMENT**  
 GR DATE 10-15-68

| FIND NO.  | PART NO. | DESCRIPTION   | QTY | MATERIAL                        | CODE IDENT                                      |
|---|----------|---|-----|---------------------------------|---|
| LIST OF MATERIAL (LM)   |          |   |     |                                 |   |
| LIMITS ON MACHINED DIMENSIONS EXCEPT AS NOTED<br>ANGULAR = ± 1° 0'<br>LINEAR:<br>.X = ± .1    .XXX = ± .010<br>.XX = ± .03    FRACTIONAL = ± 1/32 |          | 150 IN. STELLAR TELESCOPE MOUNTING                            |     | <b>WESTERN GEAR CORPORATION</b> | HEAVY MACHINERY DIVISION<br>EVERETT, WASHINGTON |
| BREAK ALL SHARP EDGES   |          | DRAWN R. SANDERS 3-22-68<br>CHECK <i>W.W.</i> 7-30-68<br>ENGR |     | SHAFT, FLANGED<br>SHAFT DRIVE   |   |
| MATERIAL<br>BAR - 2 1/4 DIA. X 2 1/2,<br>STL AISI C-1018  |          | W.G.D 107,430   |     | SIZE C 16603                    | CODE IDENT NO. 2150.530C106                     |
| APPROVED  |          |   |     | REV A                           |   |
| SCALE 1/1   |          | WT 2  | LB  | SHEET 1                         | OF 1  |