

REVISIONS

LTR	DESCRIPTION	DATE	APPROVED
-----	-------------	------	----------

SPUR GEAR DATA

DIAMETRAL PITCH	32
PRESSURE ANGLE	20°
NO. OF TEETH	60
PITCH DIA.	1.8750
OUTSIDE DIA.	1.9375
CLASS	PREC. 1
BACKLASH	
TOP HOB	

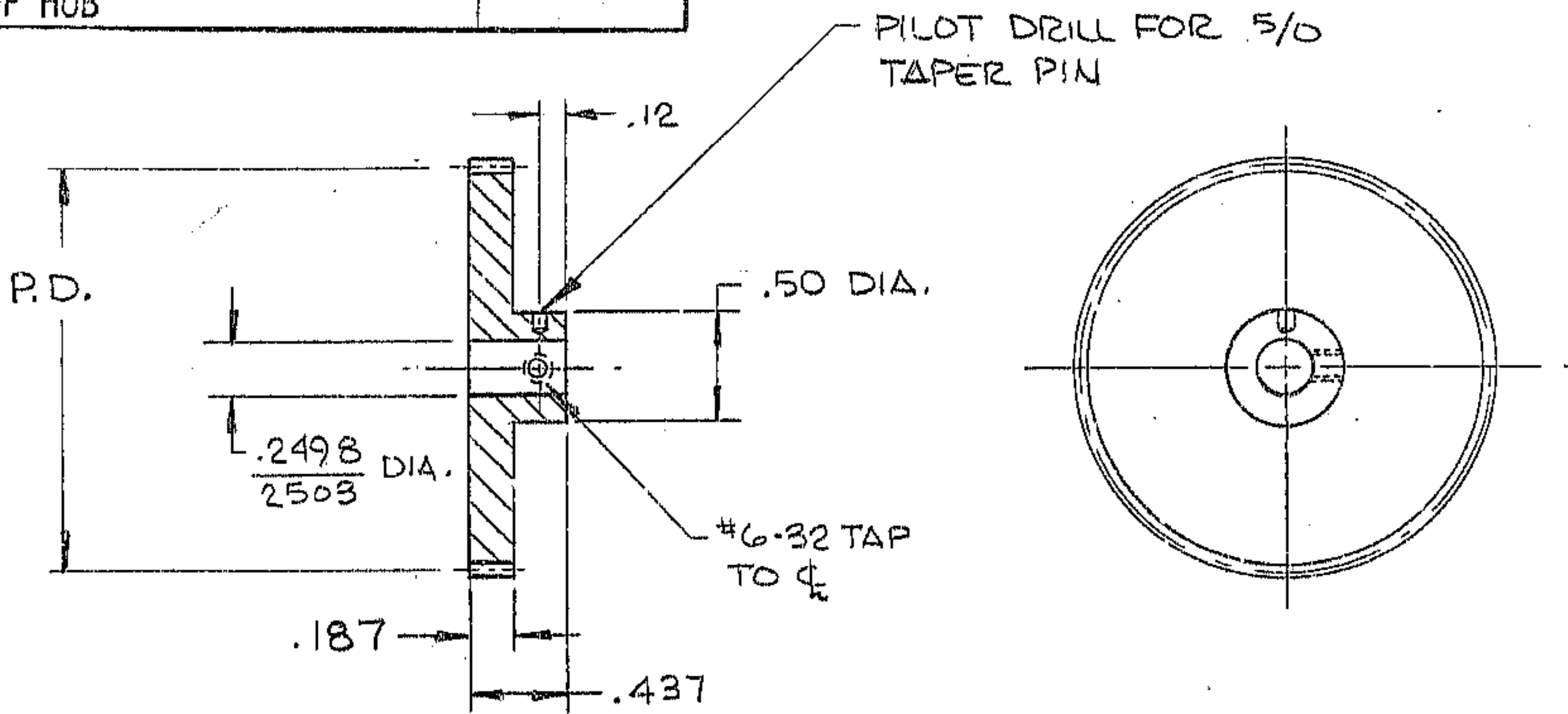

REF. FILE 1190

N/A - 2150.570E102 (2) REQ'D (x2)

NO. REQ. - NOTED PER NEXT ASSEM.  
 MAT'L - H.T. 416 ST. STL.  
 FINISH -  
 HT. TRT. -

(4) TOTAL

LIMITS ON MACHINED DIMENSIONS EXCEPT AS NOTED  
 ANGULAR ± 30' 1/2°  
 LINEAR  
 .X = ± .1  
 .XX = ± .03 .01  
 .XXX = ± .010 .003  
 FRACTIONAL ± 1/32  
 BREAK ALL SHARP EDGES .01 x 45°

150" STELLAR TELESCOPE  
 DRAWN RC 2-11-70  
 CHECK WR 2-12-70  
 ENGR [Signature] 2-20-70  
 ORIGINAL  
 APPROVED

**WESTERN GEAR CORPORATION** HEAVY MACHINERY DIVISION  
 EVERETT, WASHINGTON

GEAR  
 SEC. & PRIME FOCUS ASS'Y

SIZE	CODE IDENT NO.	REV
A	16603 2150.505A114	
SCALE FULL	WT. .15 LB	SHEET OF