

REVISIONS

LTR	DESCRIPTION	DATE	APPROVED
A	REVISED PER AURA REQ	2-20-70	WR
B	N/A #2150.000497ZE WAS 2150.570E00Z	7-31-97	J.H./PB

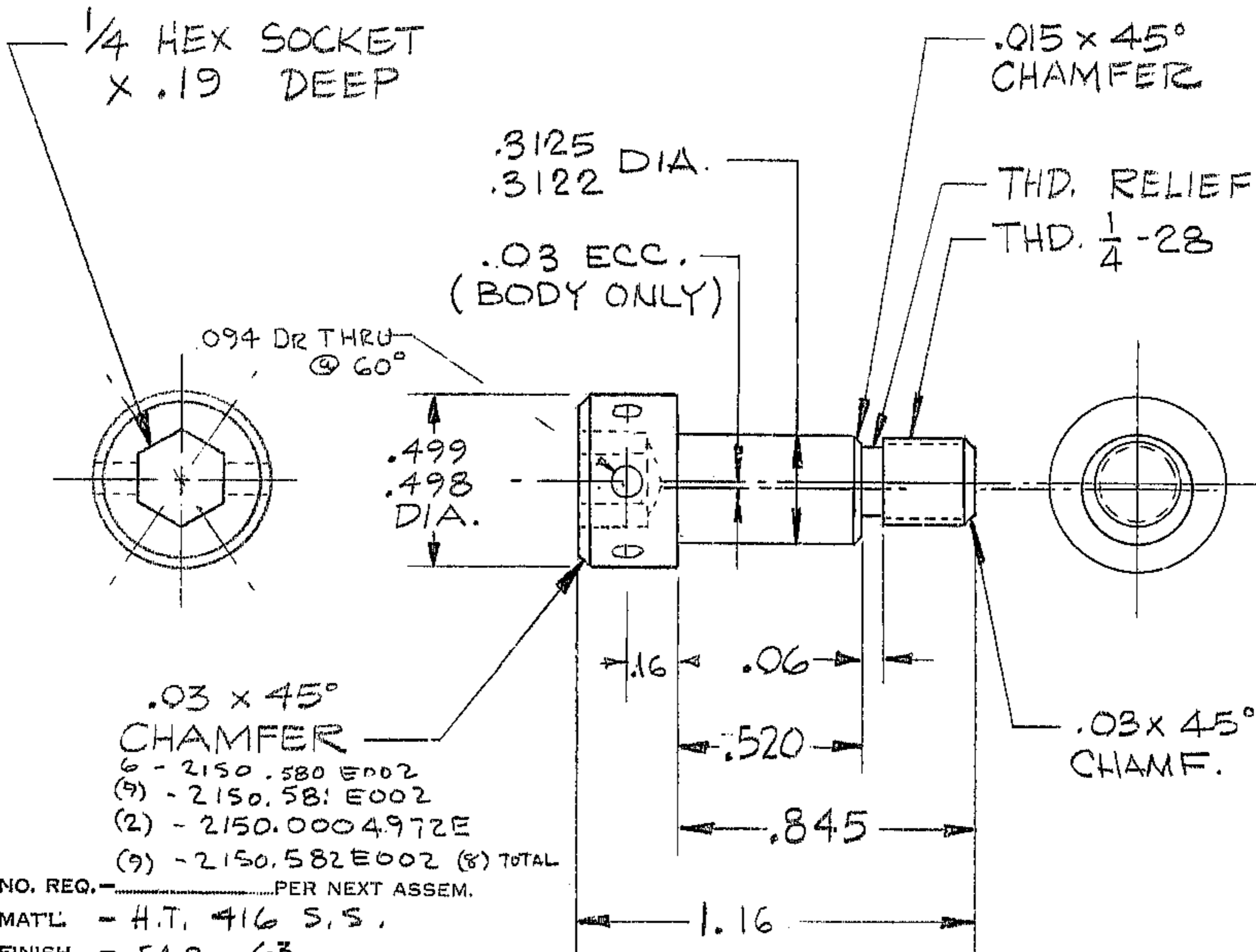

.03 x 45°  
CHAMFER  
6 - 2150.580E00Z  
(9) - 2150.581E00Z  
(2) - 2150.000497ZE  
(9) - 2150.582E00Z (8) TOTAL

NO. REQ. - PER NEXT ASSEM.  
MATL - H.T. 416 S.S.  
FINISH - F.A.O. 63  
HT. TRT. -

REF. FILE 1190

LIMITS ON  
MACHINED DIMENSIONS  
EXCEPT AS NOTED  
ANGULAR ± 1/2°  
LINEAR  
.X = ± .1  
.XX = ± .03 .01  
.XXX = ± .010 .003  
FRACTIONAL ± 1/32

150" STELLAR  
TELESCOPE

**WESTERN** HEAVY MACHINERY DIVISION  
GEAR CORPORATION EVERETT, WASHINGTON

DRAWN D.N.V.  
CHECK WR 2-10-70  
ENGR P 2-11-70

ROLLER SHAFT  
SEC. AND PRIME FOCUS ASS'Y

APPROVED

SIZE	CODE IDENT NO.	REV
<b>A</b>	<b>16603</b>	<b>B</b>
2150.505A110		

SCALE 2X WT. — LB SHEET OF