

THIS DOCUMENT CONTAINS INFORMATION PROPRIETARY TO WESTERN GEAR CORPORATION. ALL DESIGN, MANUFACTURING, REPRODUCTION, USE, PATENT, AND SALES RIGHTS REGARDING THE SAME ARE HEREBY EXPRESSLY RESERVED BY WESTERN GEAR CORPORATION. THIS DOCUMENT IS SUBMITTED FOR REFERENCE PURPOSES ONLY AND SHALL NOT BE DISCLOSED TO ANY UNAUTHORIZED PERSON OR INCORPORATED INTO ANY OTHER PROJECT.

REVISIONS				
ZONE	LTR	DESCRIPTION	DATE	APPROVED
	A	CORRECTED PER AURA REQ.	12-3-73	RC

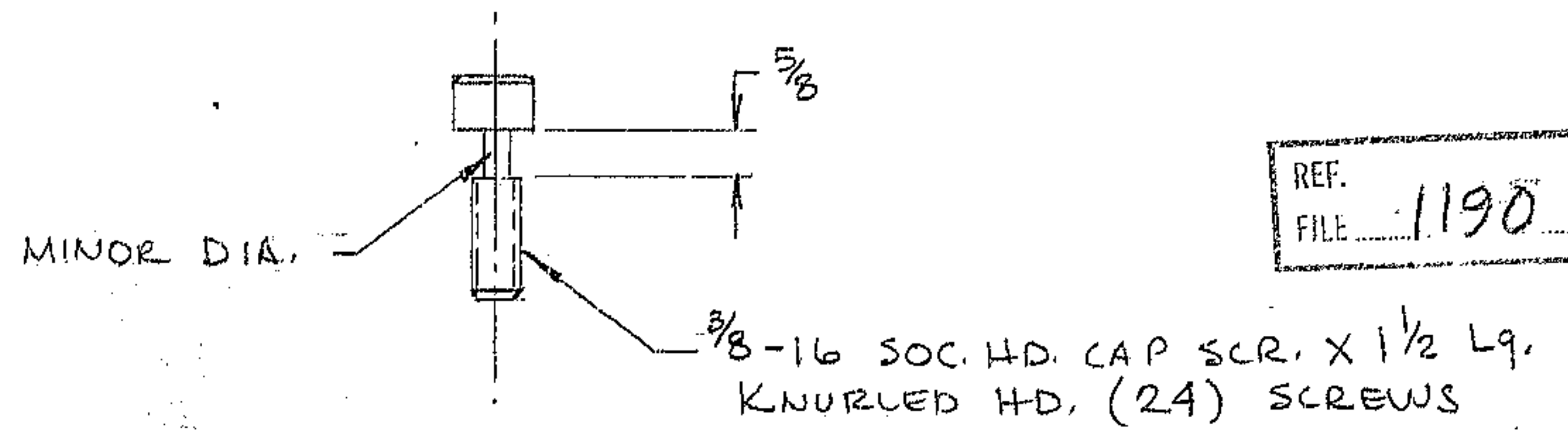
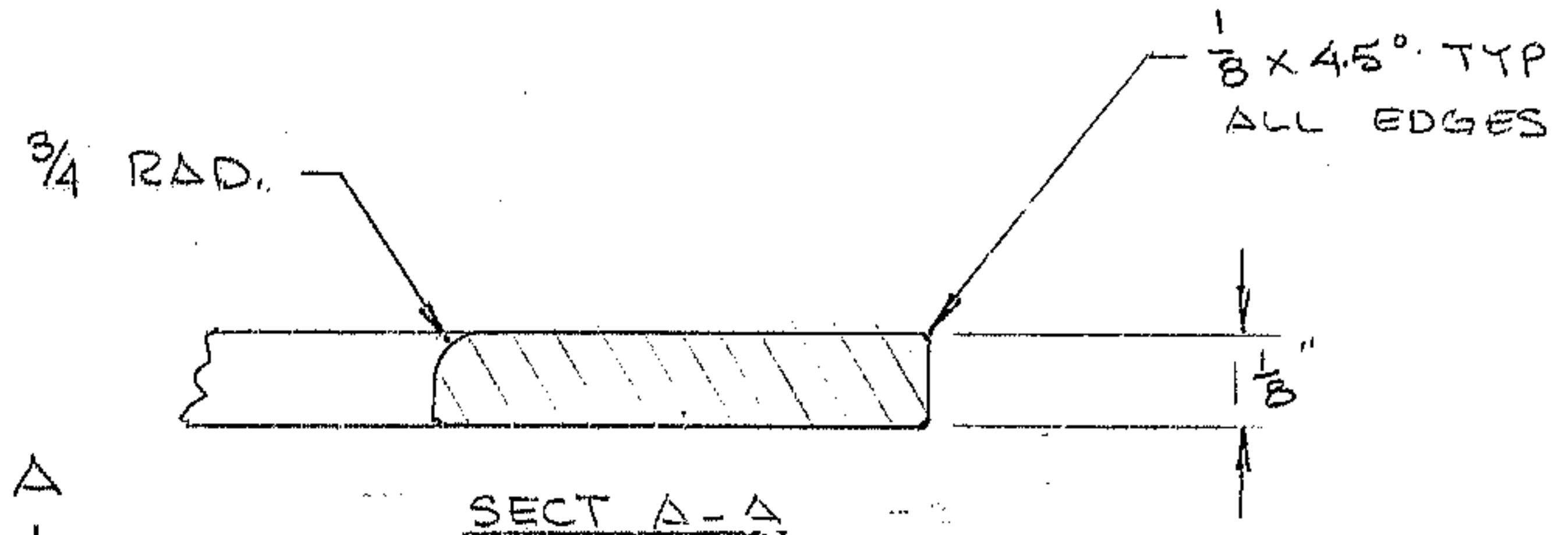
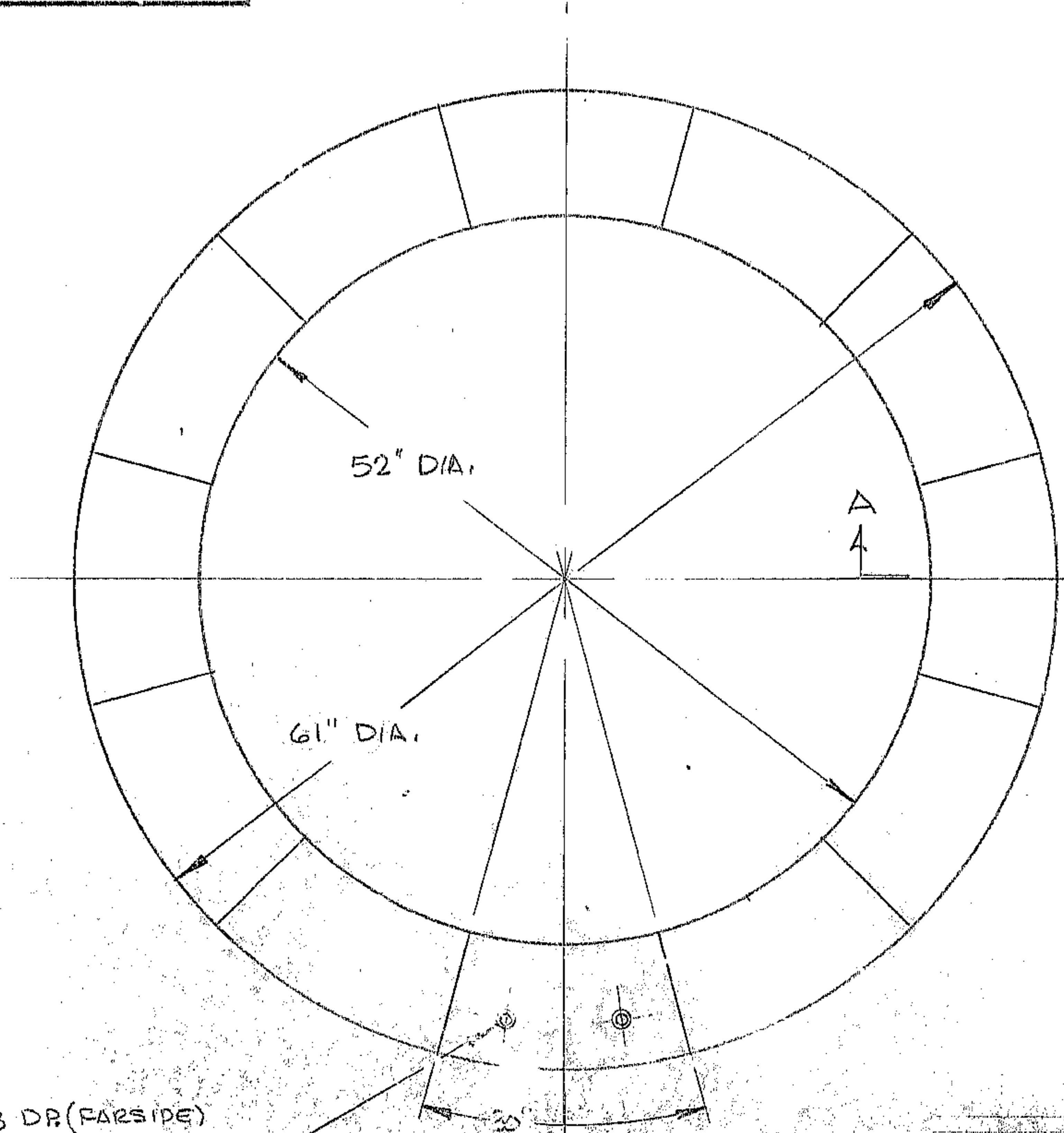

REF. FILE 1190

NO. REQ 24 PER N/A = 1
NO. REQ 12 PER N/A = 2
MAT'L - CRS
FINISH - PARKERIZE & 4002 BLK

25/64 DRILL X 7/8 DR. (FAR SIDE)
3/8-16 TAP THRU - 24 HOLES
EQ. SP. ON 56.50 B.C.

LIMITS ON MACHINED DIMENSIONS EXCEPT AS NOTED
ANGULAR ± 1/2°
LINEAR
X = ± .1
XX = ± .001
XXX = ± .0003
FRACTIONAL ± 1/32
BREAK ALL SHARP EDGES

150 STELLAR TELESCOPE
DRAWN RC
CHECK
ENGR
APPROVED

WESTERN GEAR CORPORATION		HEAVY MACHINERY DIVISION EVERETT, WASHINGTON	
COUNTER WEIGHTS SEC. MIRROR & PRIME FOCUS ASSY			
SIZE	CODE IDENT NO.	REV	
B	16603	2150.501 B.140-1	A
SCALE	WT.	LB	SHEET OF