

THIS DOCUMENT CONTAINS INFORMATION PROPRIETARY TO WESTERN GEAR CORPORATION. ALL DESIGN, MANUFACTURING, REPRODUCTION, USE, PATENT, AND SALES RIGHTS REGARDING THE SAME ARE HEREBY EXPRESSLY RESERVED BY WESTERN GEAR CORPORATION. THIS DOCUMENT IS SUBMITTED FOR REFERENCE PURPOSES ONLY AND SHALL NOT BE DISCLOSED TO ANY UNAUTHORIZED PERSON OR INCORPORATED INTO ANY OTHER PROJECT.

REVISIONS				
ZONE	LTR	DESCRIPTION	DATE	APPROVED
	A	REVISED PER AUR. REQ.	3-31-70	WR.
	B	NO. REQ. WAS 2	10-14-76	JH.

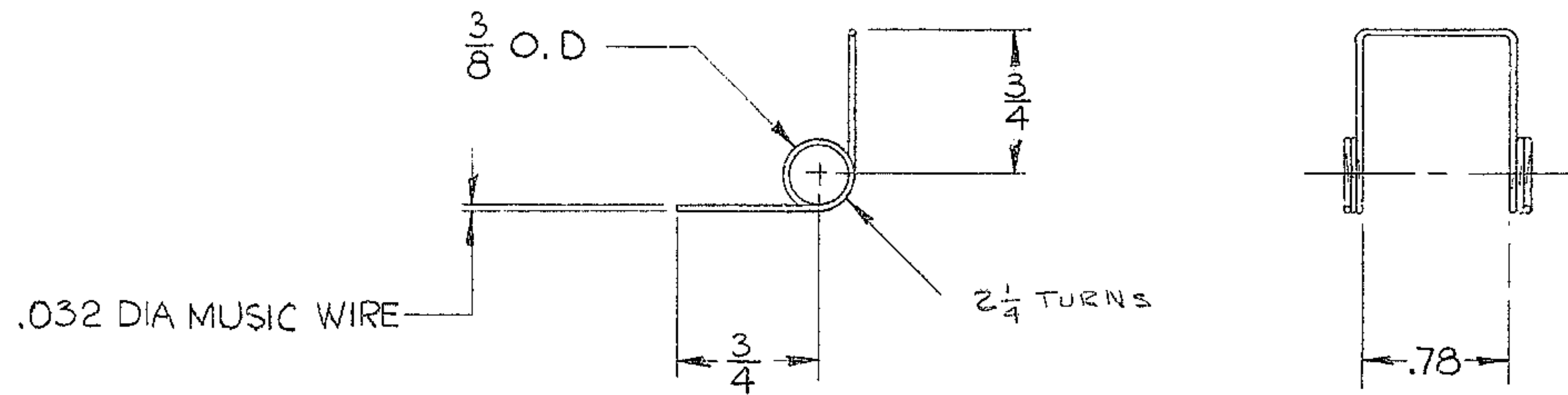

REF. FILE 1190

NO. REQ. - 1 PER NEXT ASSEM.
 MAT'L - .032 MUSIC WIRE
 FINISH -
 HT. TRT. -

LIMITS ON MACHINED DIMENSIONS EXCEPT AS NOTED ANGULAR $\pm 1^\circ - 1/2^\circ$ LINEAR X = $\pm .1$.XX = $\pm .03 - .01$.XXX = $\pm .010 - .003$ FRACTIONAL $\pm 1/32$ BREAK ALL SHARP EDGES	150 INCH STELLAR TELESCOPE	Western GEAR CORPORATION HEAVY MACHINERY DIVISION EVERETT, WASHINGTON		
	DRAWN MMS/4-23-69 CHECK WR - 4-2-70 ENGR <i>R</i> - 4-10-70	ACCESS DOOR LATCH SPRING SEC. MIRROR & PRIME FOCUS ASS'Y		
	APPROVED	SIZE B CODE IDENT NO. 16603 SCALE FULL	2150.501 B123 WT. — LB SHEET 1 OF 1	REV B

N/A-2150.501E002

BOLLER & CHIVENS DATA:
 NEXT ASSY: E-30228, JOB NO: 58070

B-31309