

THIS DOCUMENT CONTAINS INFORMATION PROPRIETARY TO WESTERN GEAR CORPORATION. ALL DESIGN, MANUFACTURING, REPRODUCTION, USE, PATENT AND SALES RIGHTS REGARDING THE SAME ARE HEREBY EXPRESSLY RESERVED BY WESTERN GEAR CORPORATION. THIS DOCUMENT IS SUBMITTED FOR REFERENCE PURPOSES ONLY AND SHALL NOT BE DISCLOSED TO ANY UNAUTHORIZED PERSON OR INCORPORATED INTO ANY OTHER PROJECT.

REVISIONS				
ZONE	LTR	DESCRIPTION	DATE	APPROVED
A		REDRAWN FROM SK-72-18-D2 G.R.	8-30-73	LD5

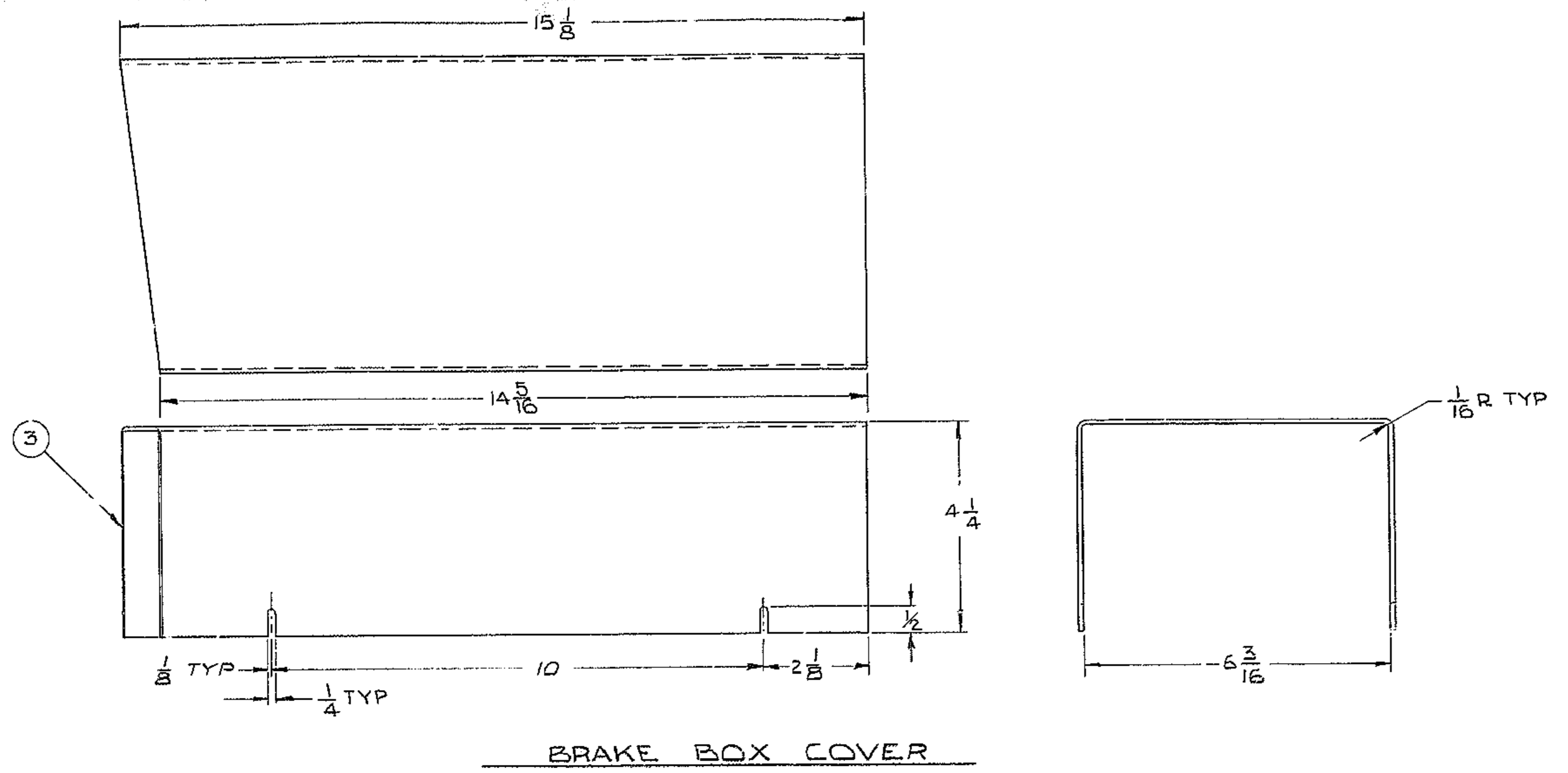

BRAKE BOX COVER

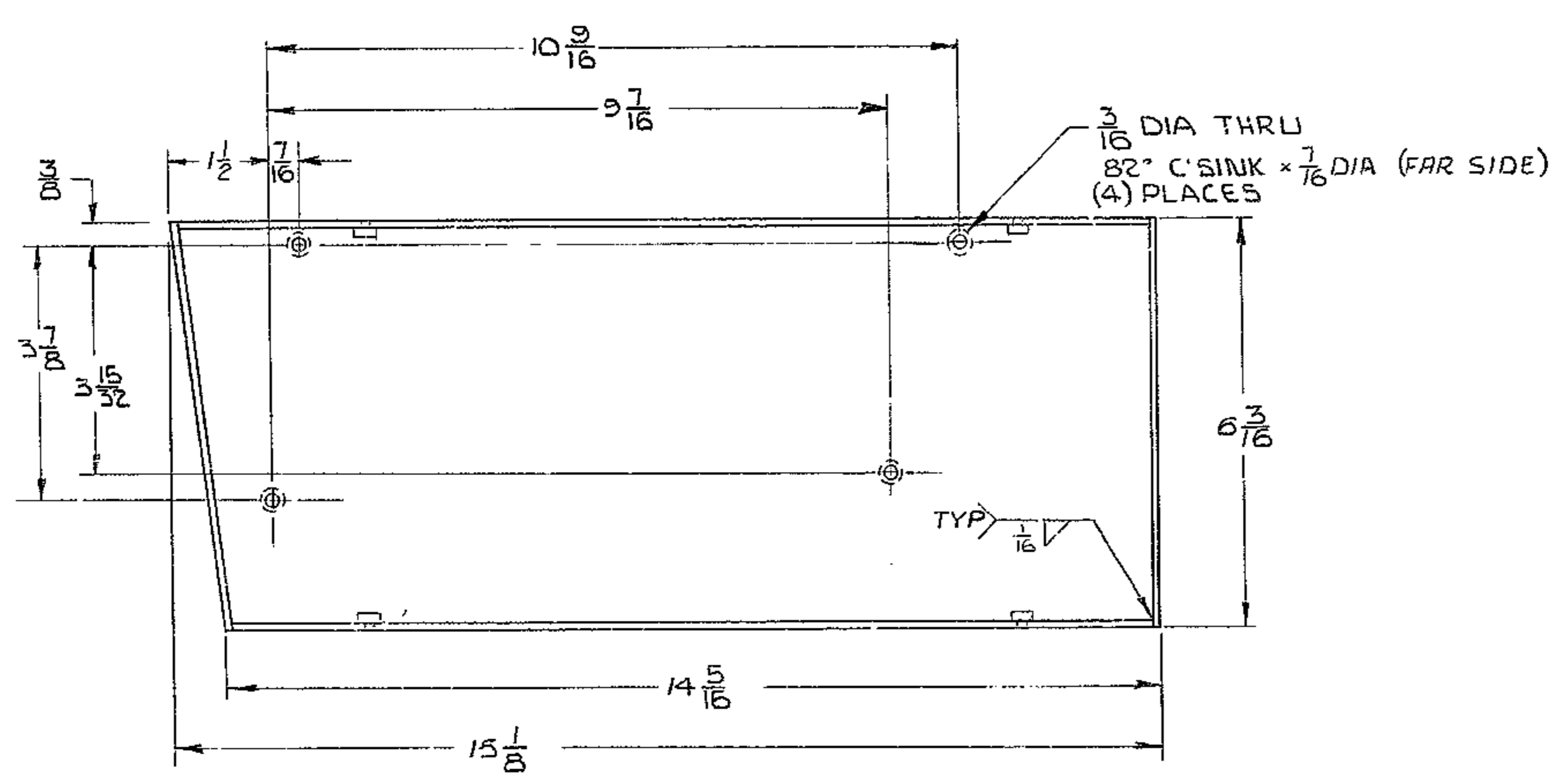

NOTE
1. INSIDE BEND RADIUS $\frac{1}{16}$ E.A.W.

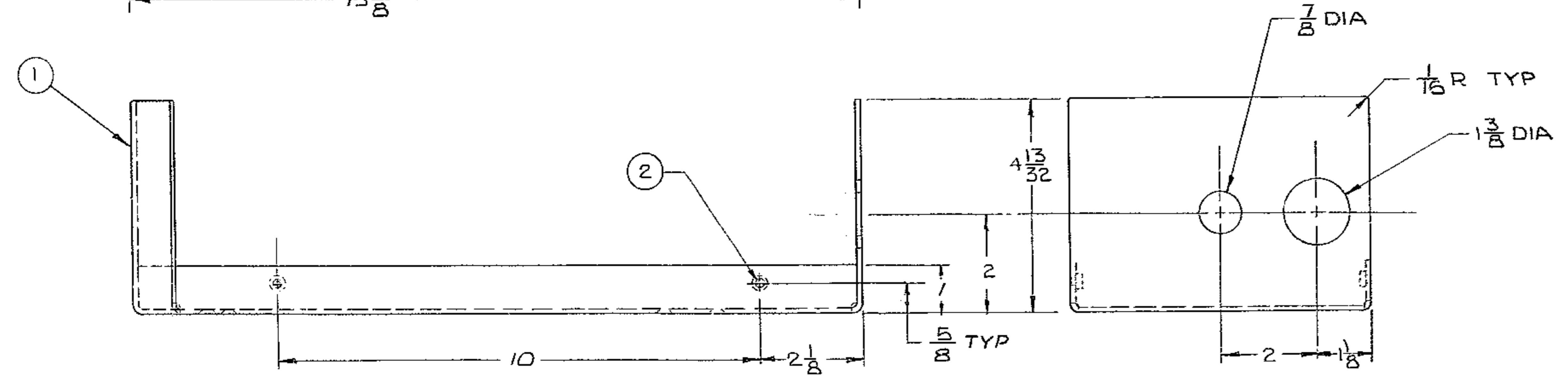

BRAKE BOX

NEXT ASSY 2150.500E002 (P/N 98)

FIND NO.	PART NO.	DESCRIPTION	QTY	MATERIAL	UNIT WEIGHT
3		.090 x $14 \frac{3}{4}$ x $15 \frac{1}{8}$	1	ALUM - 5052-H32	
2	CLS-032-2	N/LT	4	ALUMSCD	
1		.090 x $8 \frac{1}{4}$ x 24	1	ALUM - 5052-H32	

LIST OF MATERIAL (LM)

LIMITS ON MACHINED DIMENSIONS EXCEPT AS NOTED ANGULAR = $\pm 1^\circ 0'$ LINEAR: X = $\pm .1$ XXX = $\pm .010$ XX = $\pm .03$ FRACTIONAL = $\pm 1/32$ BREAK ALL SHARP EDGES	150" STELLAR TELESCOPE	WESTERN GEAR CORPORATION Heavy Machinery Division EVERETT, WASHINGTON
MATERIAL SEE L/M 1215	DRAWN CHECK ENGR LD5 8-30-73	BRAKE BOX AND COVER 1AJB4 UPPER RING ASSEMBLY
WG D306319	APPROVED	SIZE CODE IDENT NO. D 16603 2150.500-DD045
F/N NEXT ASSY QTY USED ON APPLICATION		SCALE 1/2 WT LB SHEET 1 OF 1