

THIS DOCUMENT CONTAINS INFORMATION PROPRIETARY TO WESTERN GEAR CORPORATION. ALL DESIGN, MANUFACTURING, REPRODUCTION, USE, PATENT AND SALES RIGHTS REGARDING THE SAME ARE HEREBY EXPRESSLY RESERVED BY WESTERN GEAR CORPORATION. THIS DOCUMENT IS SUBMITTED FOR REFERENCE PURPOSES ONLY AND SHALL NOT BE DISCLOSED TO ANY UNAUTHORIZED PERSON OR INCORPORATED INTO ANY OTHER PROJECT.

REVISIONS			
ZONE	LTR	DESCRIPTION	DATE
	A	REVISED BOX QUANTITY SIZE	7/15/71

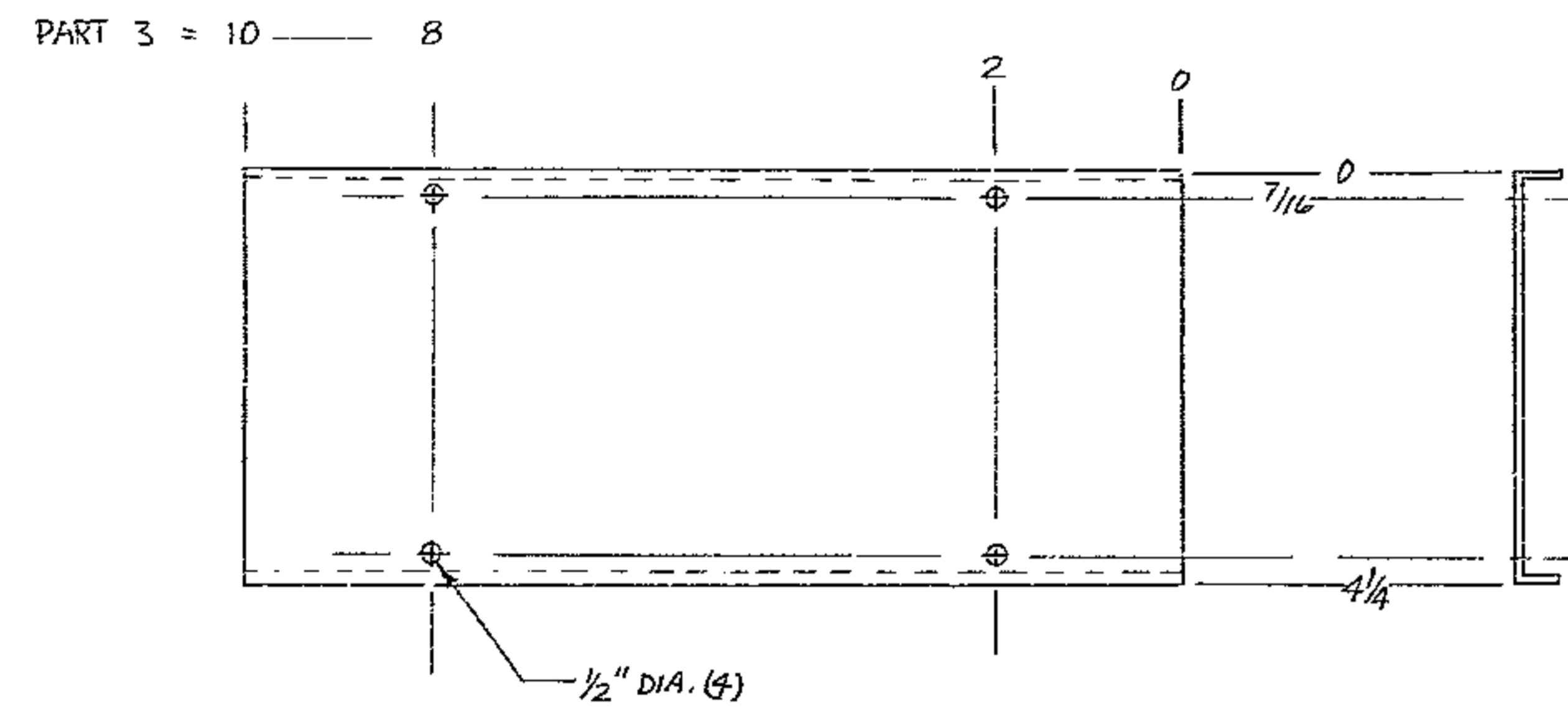
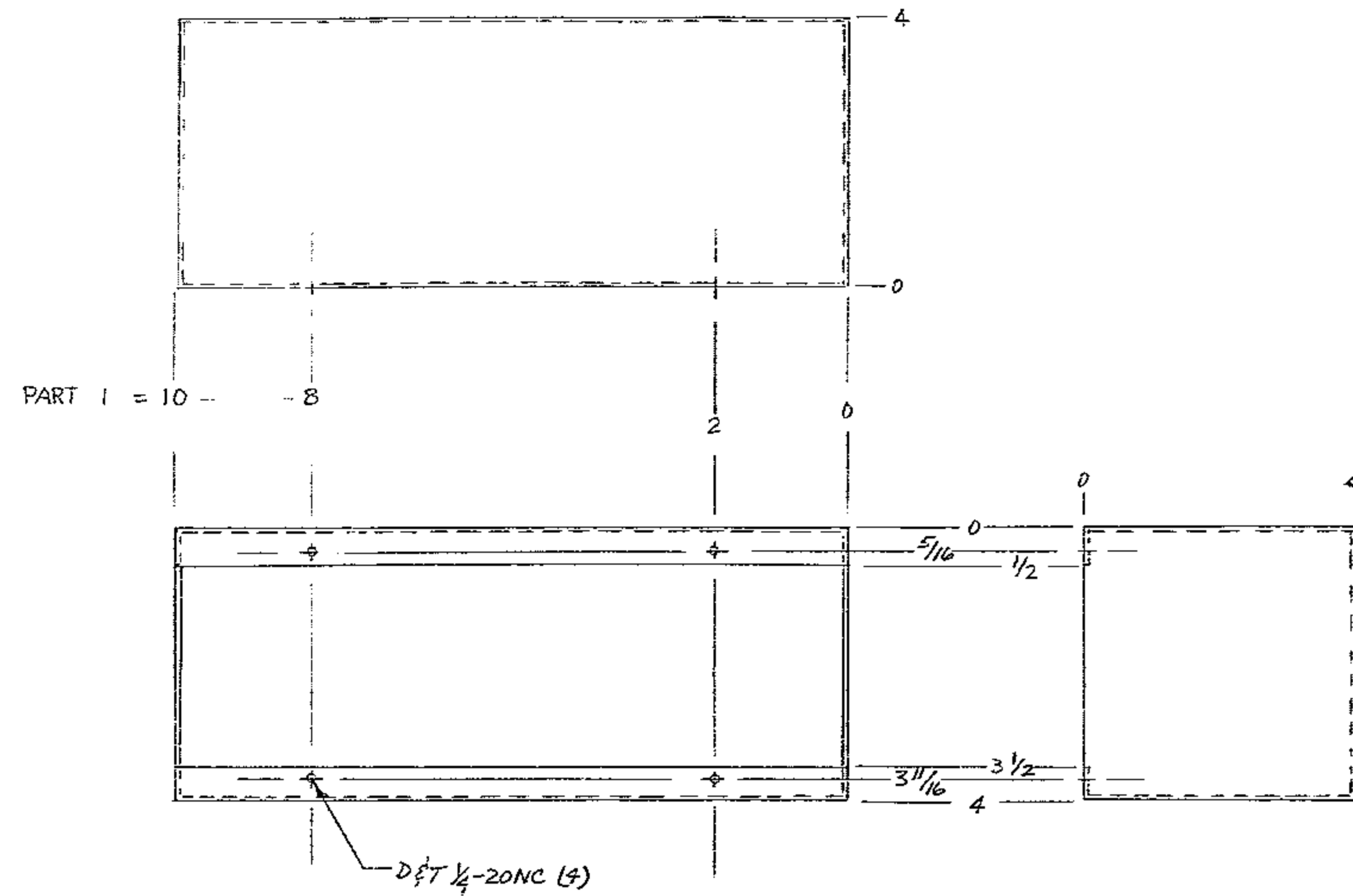

NOTES:
 1. FINISH: ALL PARTS TO BE THOROUGHLY CLEANED & DEGREASED, THEN PRIME WITH ZINC CHROMATE PRIMER.

NEXT ASSY 2150.500E002 (P/N 67)

FIND NO.	PART NO.	DESCRIPTION	QTY	MATERIAL	CODE IDENT
	3	RACEWAY COVER	2	14 GA. ALUM.	
	1	RACEWAY	2		

LIST OF MATERIAL (LM)

LIMITS ON MACHINED DIMENSIONS EXCEPT AS NOTED ANGULAR = ± 1° 0'		DRAWN G.S.		WESTERN HEAVY MACHINERY DIVISION GEAR CORPORATION EVERETT, WASHINGTON	
LINEAR: X = ± .1 .XXX = ± .010 XX = ± .03 FRACTIONAL = ± 1/32		CHECK ENGR G.S.		FABRICATION DETAILS	
MATERIAL		D303141		UPPER RING 4" X 4" RACEWAY	
SCALE 1/2" = 1"		APPROVED		SIZE D 16603	CODE IDENT NO. 2150.500-0091
				REV A	

SCALE 1/2" = 1" WT LB SHEET OF