

REVISIONS				
ZONE	LTR	DESCRIPTION	DATE	APPROVED
	A	CORRECTED PER AURA REQ.	12-3-73	RL

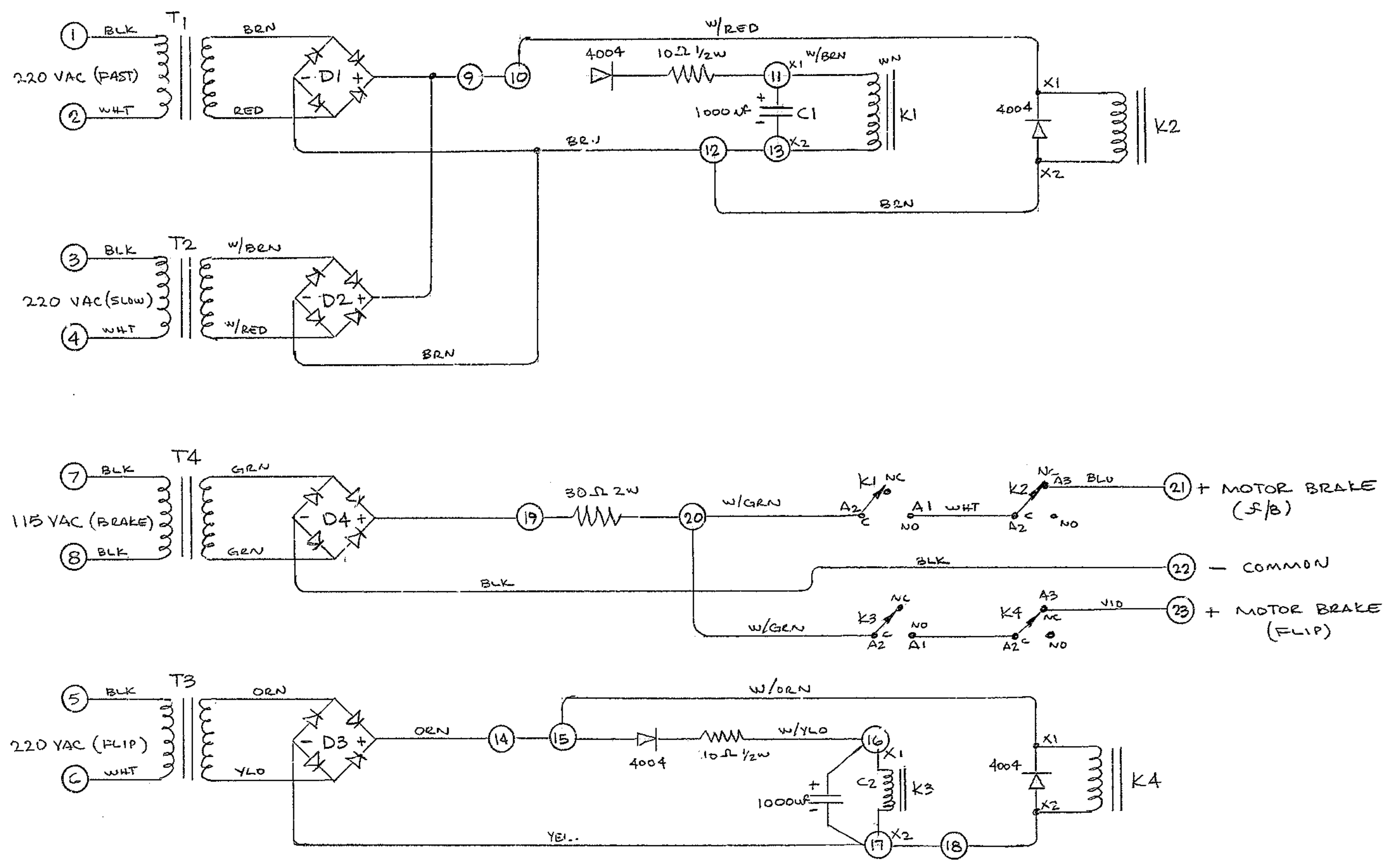

REF. 1215

NO REQ 2 PER N/A (REF)

NC	C	NO
• F3	• F2	• F1
• E3	• E2	• E1
• D3	• D2	• D1
• C3	• C2	• C1
• B3	• B2	• B1
• A3	• A2	• A1

LEACH RELAY #9226-4429

○ ← DESIGNATES BARRIER STRIP POSITION OCCUPIED

N/A 2150.500 D 102
N/A 2150.500 D 102

FIND NO.	PART NO.	DESCRIPTION	QTY	MATERIAL	CODE IDENT
LIST OF MATERIAL (LM)					
LIMITS ON MACHINED DIMENSIONS EXCEPT AS NOTED ANGULAR = ± 1° 0'		150 STELLAR TELESCOPE		WESTERN GEAR CORPORATION HEAVY MACHINERY DIVISION EVERETT, WASHINGTON	
LINEAR: X = ± .1 .XXX = ± .010 .XX = ± .03 FRACTIONAL = ± 1/32		DRAWN RC CHECK ENGR		DC POWER SUPPLY ELECTRICAL SCHEMATIC	
BREAK ALL SHARP EDGES		MATERIAL		SIZE CODE IDENT NO. REV	
REF.		APPROVED		C 16603 2150.500 C 107 A	
SCALE		WT		LB SHEET 1 OF 1	