

NOTES: UNLESS OTHERWISE NOTED

1. REMOVE ALL BURRS AND SHARP EDGES \sqrt{R} MAX
2. MACHINED SURFACE ROUGHNESS $\sqrt{125}$
3. MAT'L: TOOL STEEL
4. HEAT TREAT R/C 54-58

REVISIONS				
LTR	DESCRIPTION	ECR	DATE	BY/APVD

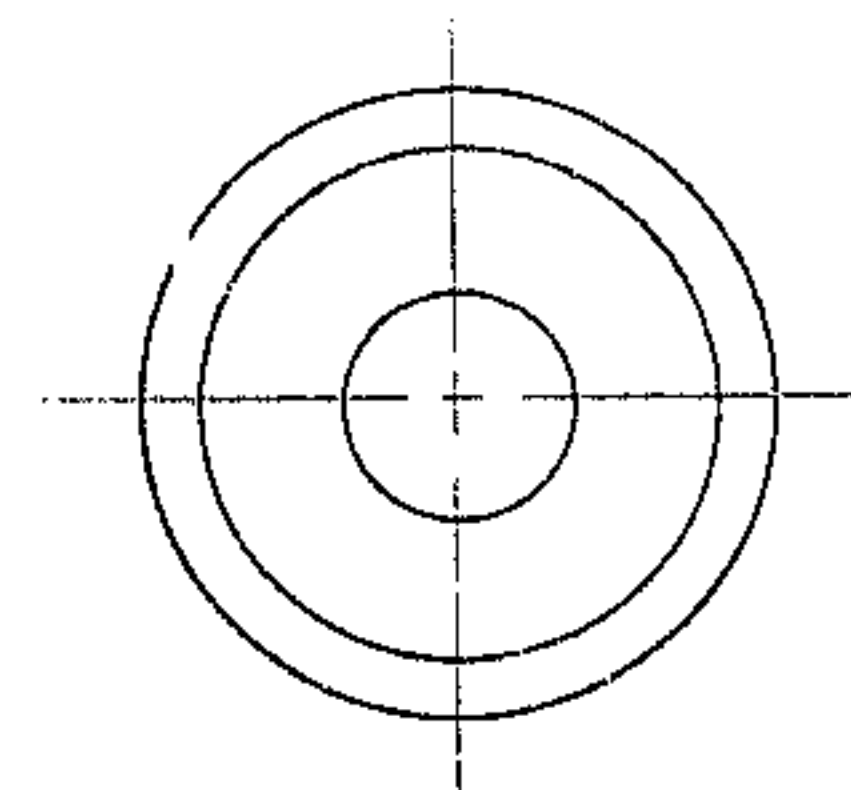
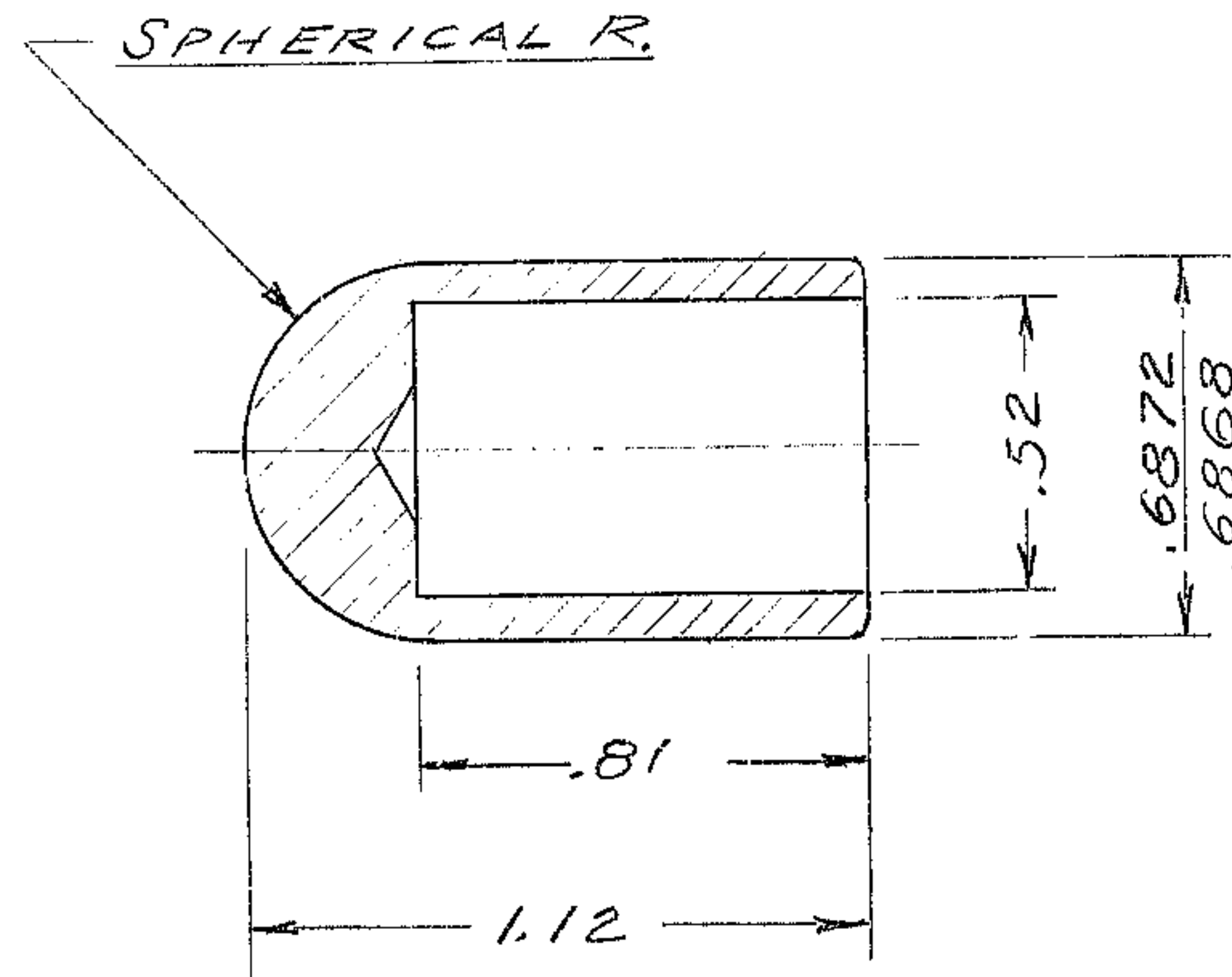

TOLERANCES UNLESS OTHERWISE NOTED			KITT PEAK NATIONAL OBSERVATORY OPERATED BY THE ASSOCIATION OF UNIVERSITIES FOR RESEARCH IN ASTRONOMY, INC. UNDER CONTRACT WITH NATIONAL SCIENCE FOUNDATION		
DECIMALS	FRACTIONS	ANGULAR			
.XX ± .03	± —	± 0° 30'	NEXT ASSEMBLY		
.XXX ± .010			2150-340-E502		
NAME			REF FILE		
PLUNGER			1186		
SCALE 2X	DESIGNED BY	DATE	APPROVED BY	DATE	DWG NO.
PRINT ISSUED	DRAWN BY	DATE	APPROVED BY	DATE	2150.340-B504
	CHECKED BY	DATE	APPROVED BY	DATE	RELEASE DATE 11-12-84
					REV