

THIS DOCUMENT CONTAINS INFORMATION PROPRIETARY TO WESTERN GEAR CORPORATION. ALL DESIGN, MANUFACTURING, REPRODUCTION, USE, PATENT AND SALES RIGHTS REGARDING THE SAME ARE HEREBY EXPRESSLY RESERVED BY WESTERN GEAR CORPORATION. THIS DOCUMENT IS SUBMITTED FOR REFERENCE PURPOSES ONLY AND SHALL NOT BE DISCLOSED TO ANY UNAUTHORIZED PERSON OR INCORPORATED INTO ANY OTHER PROJECT.

REVISIONS				
ZONE	LTR	DESCRIPTION	DATE	APPROVED

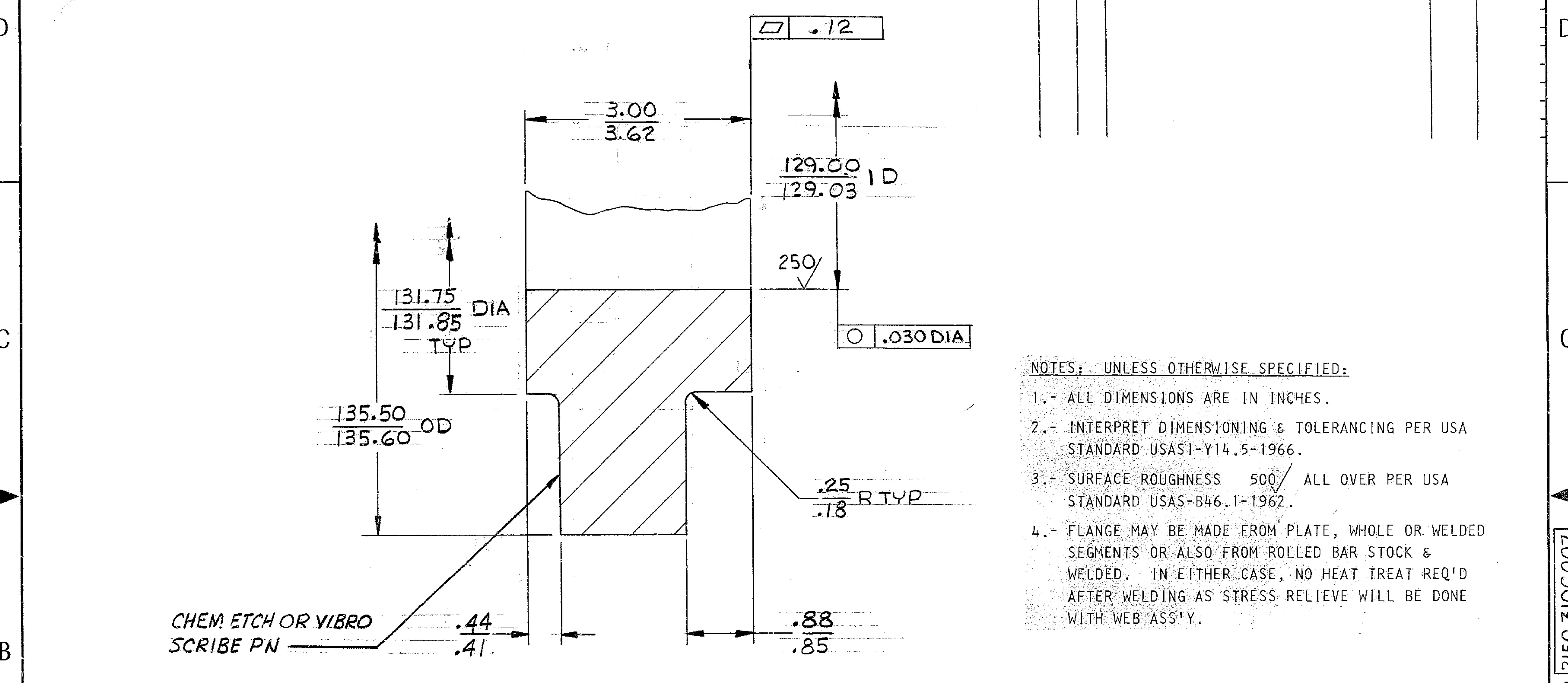

- NOTES: UNLESS OTHERWISE SPECIFIED:
- ALL DIMENSIONS ARE IN INCHES.
 - INTERPRET DIMENSIONING & TOLERANCING PER USA STANDARD USAS1-Y14.5-1966.
 - SURFACE ROUGHNESS 500/ ALL OVER PER USA STANDARD USAS-B46.1-1962.
 - FLANGE MAY BE MADE FROM PLATE, WHOLE OR WELDED SEGMENTS OR ALSO FROM ROLLED BAR STOCK & WELDED. IN EITHER CASE, NO HEAT TREAT REQ'D AFTER WELDING AS STRESS RELIEVE WILL BE DONE WITH WEB ASS'Y.

REF. FILE 1183

NEXT ASSY: 2150.310E003 & 2150.310E253 (82402-44175R103 & 44175R253)

FIND NO.	PART NO.	DESCRIPTION	QTY	MATERIAL	CODE IDENT
LIST OF MATERIAL (LM)					
LIMITS ON MACHINED DIMENSIONS EXCEPT AS NOTED ANGULAR = ± 1° 0'		150 IN. STELLAR TELESCOPE MTG		Western HEAVY MACHINERY DIVISION GEAR CORPORATION EVERETT, WASHINGTON	
LINEAR: .X = ± .1 .XXX = ± .010 .XX = ± .03 FRACTIONAL = ± 1/32		DRAWN <i>F.L. Bell</i>	9-10-69	FLANGE, OUTER-WEB ASSY- BULL GEAR - R.A. AND DECL.	
BREAK ALL SHARP EDGES		CHECK <i>VVG</i>	10-20-69		
MATERIAL		ENGR <i>VVG</i>	10-20-69		
ASTM-A36 SEE NOTE NO. 4.		82402-44175D107	SIZE C	CODE IDENT NO. 16603	2150.310C007
APPROVED <i>John H. Shook</i>		SCALE 1/1		WT	LB SHEET 1 OF 1

44175D107