

4

3

2

1

THIS DOCUMENT CONTAINS INFORMATION PROPRIETARY TO WESTERN GEAR CORPORATION. ALL DESIGN, MANUFACTURING, REPRODUCTION, USE, PATENT AND SALES RIGHTS REGARDING THE SAME ARE HEREBY EXPRESSLY RESERVED BY WESTERN GEAR CORPORATION. THIS DOCUMENT IS SUBMITTED FOR REFERENCE PURPOSES ONLY AND SHALL NOT BE DISCLOSED TO ANY UNAUTHORIZED PERSON OR INCORPORATED INTO ANY OTHER PROJECT.

REVISIONS				
ZONE	LTR	DESCRIPTION	DATE	APPROVED

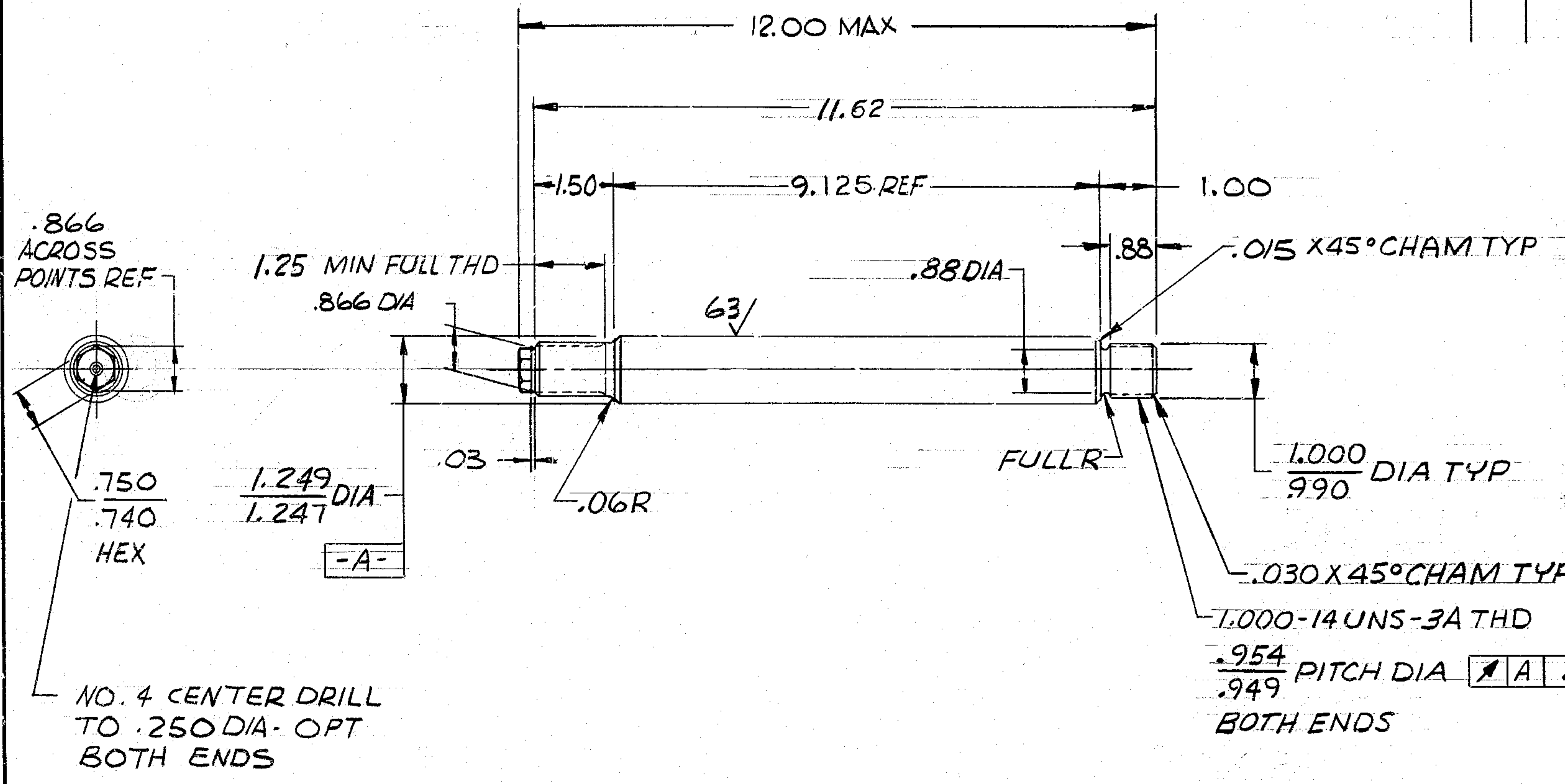

- NOTES: UNLESS OTHERWISE SPECIFIED:
- 1.- ALL DIMENSIONS ARE IN INCHES.
 - 2.- INTERPRET DIMENSIONING AND TOLERANCING PER USA STANDARD USASI-Y14.5-1966.
 - 3.- SURFACE ROUGHNESS 125 ✓ ALL OVER PER USA STANDARD USAS-B46.1-1962.
 - 4.- BAG AND IDENTIFY WITH P N: 2150.300C029
 - 5.- HEAT TREAT: R_C 32 TO 36 PER MIL-H-6875.

NEXT ASSY: 2150.300E002 (82402-44175R2)

FIND NO.	PART NO.	DESCRIPTION	QTY	MATERIAL	CODE IDENT
LIST OF MATERIAL (LM)					
LIMITS ON MACHINED DIMENSIONS EXCEPT AS NOTED ANGULAR = ± 1° 0'		150 IN. STELLAR TELESCOPE MOUNTING		WESTERN HEAVY MACHINERY DIVISION EVERETT, WASHINGTON	
LINEAR: X = ± .1 XXX = ± .010 .XX = ± .03 FRACTIONAL = ± 1/32		DRAWN <i>Hankson</i> 7-31-69	CHECK <i>B. SIKLI</i> 10-30-69	SHAFT GUIDE, THREADED-DRIVE GEARBOX	
BREAK ALL SHARP EDGES		ENGR			
MATERIAL					
STL BAR 4140 QQ-5-624		82402-44175D29		SIZE C	CODE IDENT NO. 16603 2150.300C029
APPROVED <i>JS</i>				SCALE 1/2	WT
				LB	SHEET / OF /

REF. FILE 1181

620.300C029

REV

44175D29