

THIS DOCUMENT CONTAINS INFORMATION PROPRIETARY TO WESTERN GEAR CORPORATION. ALL DESIGN, MANUFACTURING, REPRODUCTION, USE, PATENT, AND SALES RIGHTS REGARDING THE SAME ARE HEREBY EXPRESSLY RESERVED BY WESTERN GEAR CORPORATION. THIS DOCUMENT IS SUBMITTED FOR REFERENCE PURPOSES ONLY AND SHALL NOT BE DISCLOSED TO ANY UNAUTHORIZED PERSON OR INCORPORATED INTO ANY OTHER PROJECT.

REVISIONS				
ZONE	LTR	DESCRIPTION	DATE	APPROVED

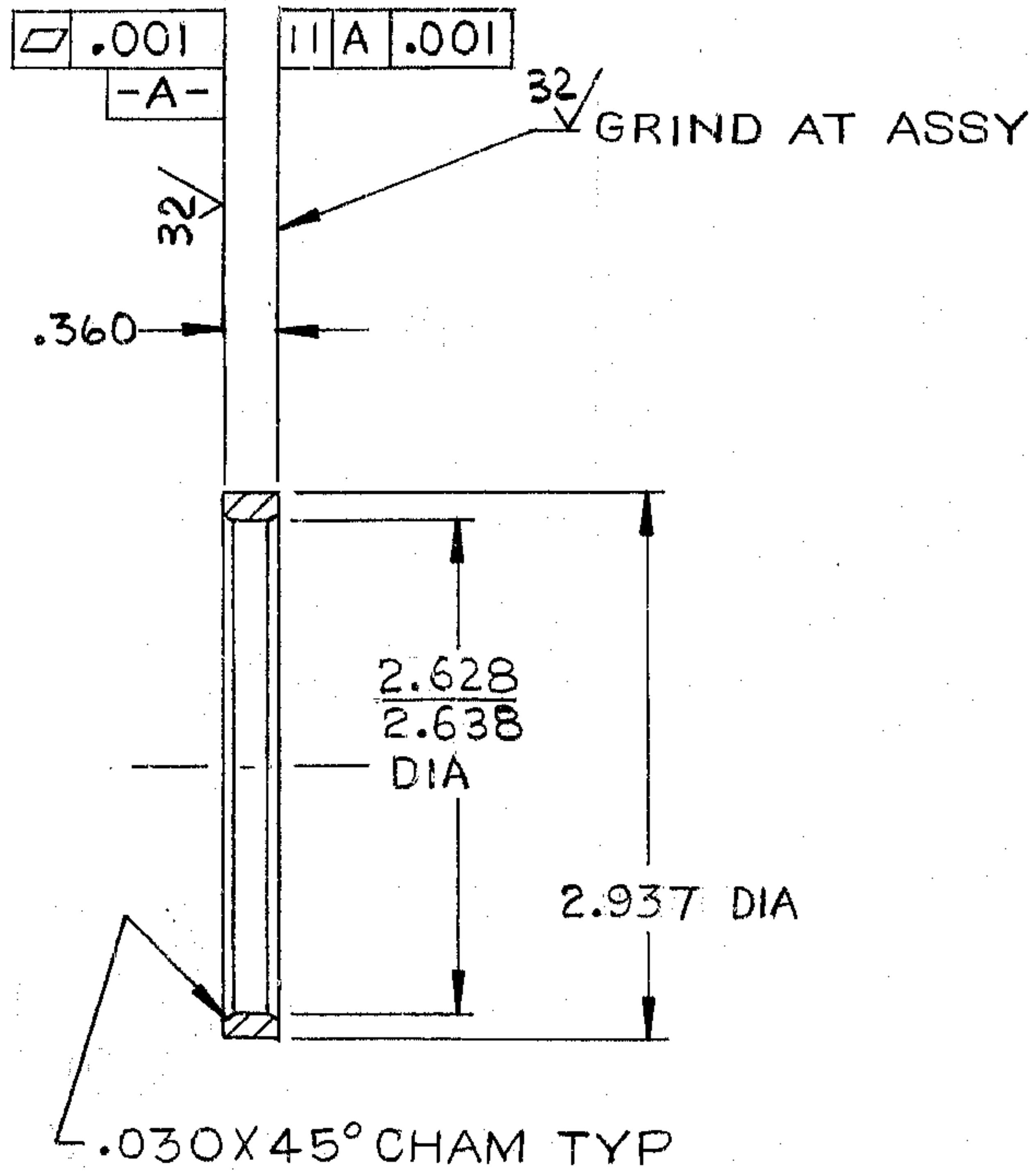

- NOTES: UNLESS OTHERWISE SPECIFIED:
- 1.- ALL DIMENSIONS ARE IN INCHES.
 - 2.- INTERPRET DIMENSIONS AND TOLERANCING PER USA STANDARD USAS1-Y14.5-1966.
 - 3.- SURFACE ROUGHNESS 125/ ALL OVER PER USA STANDARD USAS-B46.1-1962.
 - 4.- MATERIAL: STL 4130 PER QQ-S-624.
 - 5.- TAG AND IDENTIFY WITH PN: 2150.300B034.

REF. FILE 1181

NEXT ASSY: 2150.300E002 (82402-44175R2)

LIMITS ON MACHINED DIMENSIONS EXCEPT AS NOTED ANGULAR ± 1° 0' LINEAR X = ± .1 .XX = ± .03 .XXX = ± .010 FRACTIONAL ± 1/32	150 IN. STELLAR TELESCOPE MTG	WESTERN HEAVY MACHINERY DIVISION GEAR CORPORATION EVERETT, WASHINGTON	
	DRAWN <i>J.L. Bell</i> 7-28-69 CHECK <i>B. SIKLI</i> 10-30-69 ENGR	RING SPACER - DRIVE GEARBOX	
BREAK ALL SHARP EDGES	82402-44175C34	SIZE B	CODE IDENT NO. 16603
	APPROVED <i>JL</i>	2150.300B034	REV
		SCALE 1/1	WT. — LB SHEET 1 OF 1

REV

44175C34