

THIS DOCUMENT CONTAINS INFORMATION PROPRIETARY TO WESTERN GEAR CORPORATION. ALL DESIGN, MANUFACTURING, REPRODUCTION, USE, PATENT, AND SALES RIGHTS REGARDING THE SAME ARE HEREBY EXPRESSLY RESERVED BY WESTERN GEAR CORPORATION. THIS DOCUMENT IS SUBMITTED FOR REFERENCE PURPOSES ONLY AND SHALL NOT BE DISCLOSED TO ANY UNAUTHORIZED PERSON OR INCORPORATED INTO ANY OTHER PROJECT.

REVISIONS				
ZONE	LTR	DESCRIPTION	DATE	APPROVED

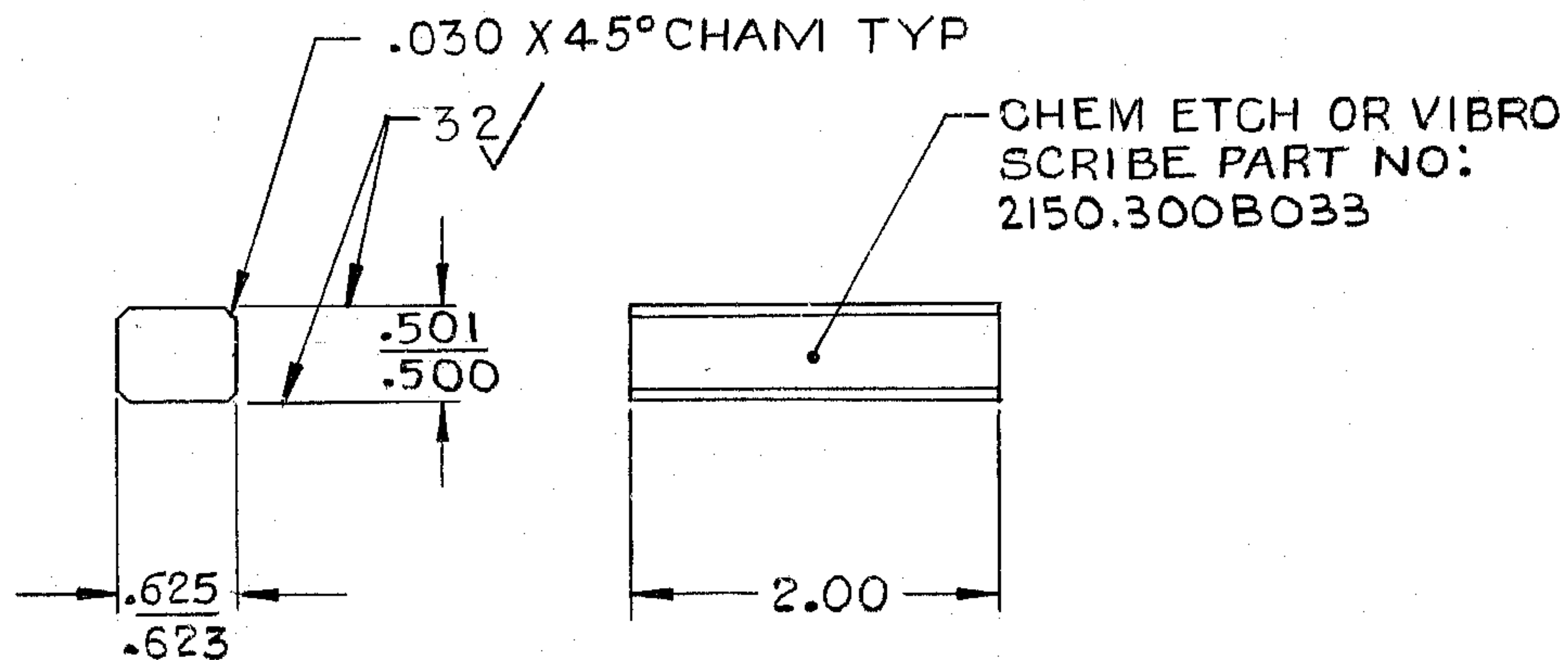

- NOTES: UNLESS OTHERWISE SPECIFIED:
- 1.- ALL DIMENSIONS ARE IN INCHES.
  - 2.- INTERPRET DIMENSIONING & TOLERANCING PER USA STANDARD USASI-Y14.5-1966.
  - 3.- SURFACE ROUGHNESS 63/ ALL OVER PER USA STANDARD USAS-B46.1-1962.
  - 4.- MATERIAL STL 4140 PER QQ-S-624.
  - 5.- HEAT TREAT: R<sub>C</sub> 32-40 PER MIL-H-6875.

REF. FILE 1181

NEXT ASSY: 2150.300E002 (82402-44175 R2)

LIMITS ON MACHINED DIMENSIONS EXCEPT AS NOTED ANGULAR ± 1° LINEAR X = ± .1 XX = ± .03 XXX = ± .010 FRACTIONAL ± 1/32  BREAK ALL SHARP EDGES	150 IN. STELLAR TELESCOPE MTG		<b>WESTERN</b> HEAVY MACHINERY DIVISION GEAR CORPORATION EVERETT, WASHINGTON	
	DRAWN J.S. Bell 7-28-69		KEY —	
	CHECK B. SIKLID 10-24-69		DRIVE GEARBOX	
	ENGR			
APPROVED [Signature]		SIZE B	CODE IDENT NO. 16603	REV 2150.300B033
82402-44175C33		SCALE 1/1	WT. —	LB SHEET 1 OF 1

REV [Symbol]

44175C33