

THIS DOCUMENT CONTAINS INFORMATION PROPRIETARY TO WESTERN GEAR CORPORATION. ALL DESIGN, MANUFACTURING, REPRODUCTION, USE, PATENT, AND SALES RIGHTS REGARDING THE SAME ARE HEREBY EXPRESSLY RESERVED BY WESTERN GEAR CORPORATION. THIS DOCUMENT IS SUBMITTED FOR REFERENCE PURPOSES ONLY AND SHALL NOT BE DISCLOSED TO ANY UNAUTHORIZED PERSON OR INCORPORATED INTO ANY OTHER PROJECT.

REVISIONS				
ZONE	LTR	DESCRIPTION	DATE	APPROVED
D-4	A	PARA WAS RUN OUT	1-30-70	EFW

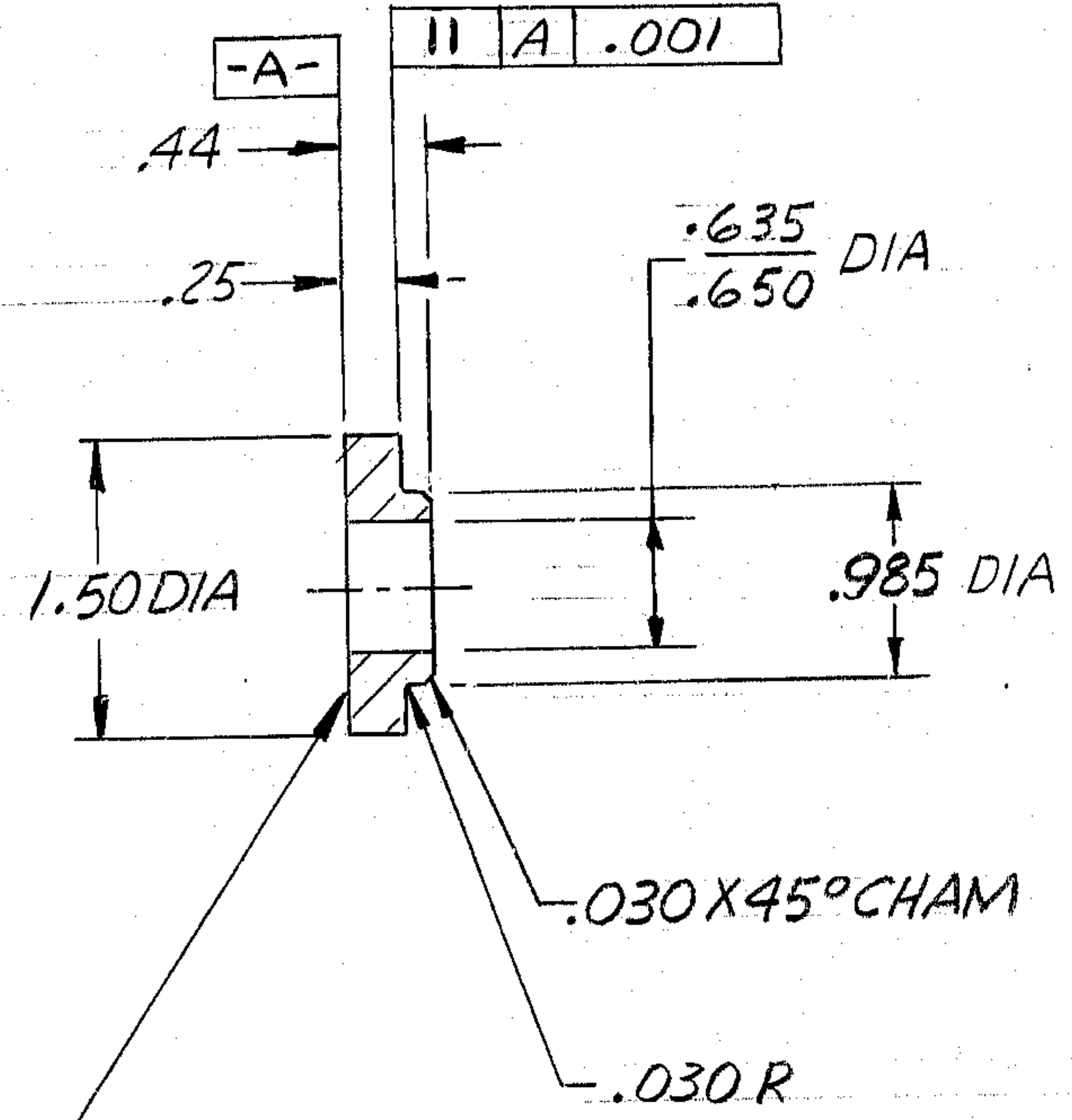

NOTES: UNLESS OTHERWISE SPECIFIED:

- 1.- ALL DIMENSIONS ARE IN INCHES.
- 2.- INTERPRET DIMENSIONING AND TOLERANCING PER USA STANDARD USAS1-Y14.5-1966.
- 3.- SURFACE ROUGHNESS 125√ ALL OVER PER USA STANDARD USAS-B46.1-1962.
- 4.- MATERIAL: STEEL BAR B1113, QQ-S-63T.
- 5.- APPLY BLACK OXIDE ALL OVER PER MIL-C-13924, CLASS 1.

REF. FILE 1181

CHEM ETCH OR VIBRO SCRIBE FN:
2150.300B027

NEXT ASSY: 2150.300E002 (82402-44175R2)

LIMITS ON MACHINED DIMENSIONS EXCEPT AS NOTED ANGULAR ± 1° 0' LINEAR X = ± .1 XX = ± .03 XXX = ± .010 FRACTIONAL ± 1/32 BREAK ALL SHARP EDGES	150 IN. STELLAR	WESTERN HEAVY MACHINERY DIVISION EVERETT, WASHINGTON	PLUG, GUIDE - DRIVE GEARBOX	
	TELESCOPE MOUNTING			
	DRAWN Henderson 7-31-69	CODE IDENT NO. 16603	2150.300B027	REV A
	CHECK B.S.W. 10-24-69	82402-44175C27	SCALE 1/1	WT. LB SHEET 1 OF 1

REV A

44175C27