

THIS DOCUMENT CONTAINS INFORMATION PROPRIETARY TO WESTERN GEAR CORPORATION. ALL DESIGN, MANUFACTURING, REPRODUCTION, USE, PATENT, AND SALES RIGHTS REGARDING THE SAME ARE HEREBY EXPRESSLY RESERVED BY WESTERN GEAR CORPORATION. THIS DOCUMENT IS SUBMITTED FOR REFERENCE PURPOSES ONLY AND SHALL NOT BE DISCLOSED TO ANY UNAUTHORIZED PERSON OR INCORPORATED INTO ANY OTHER PROJECT.

REVISIONS

ZONE	LTR	DESCRIPTION	DATE	APPROVED

1.062 ID

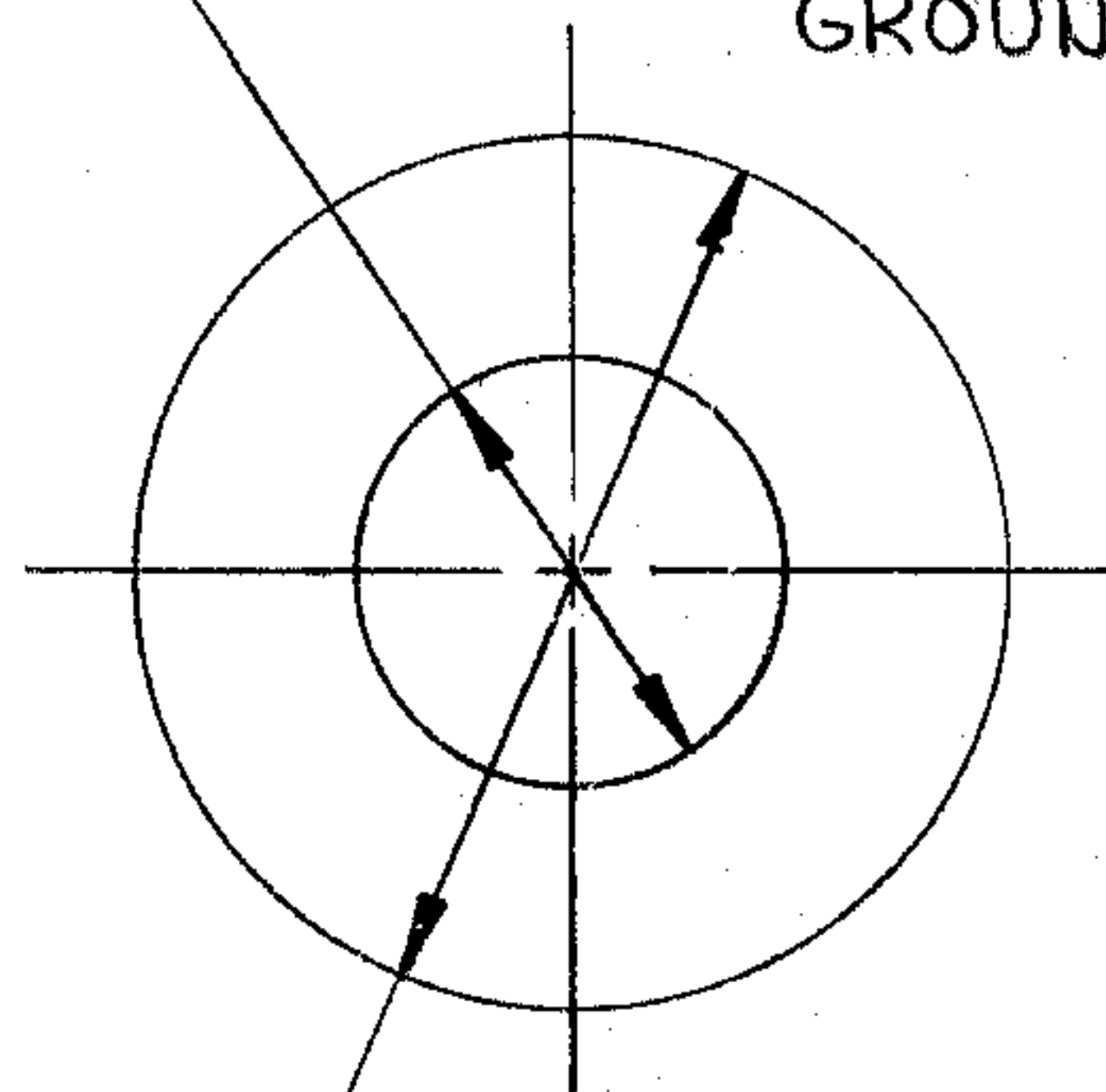

2.375 OD

THIS END TO BE
GROUND AT ASSY

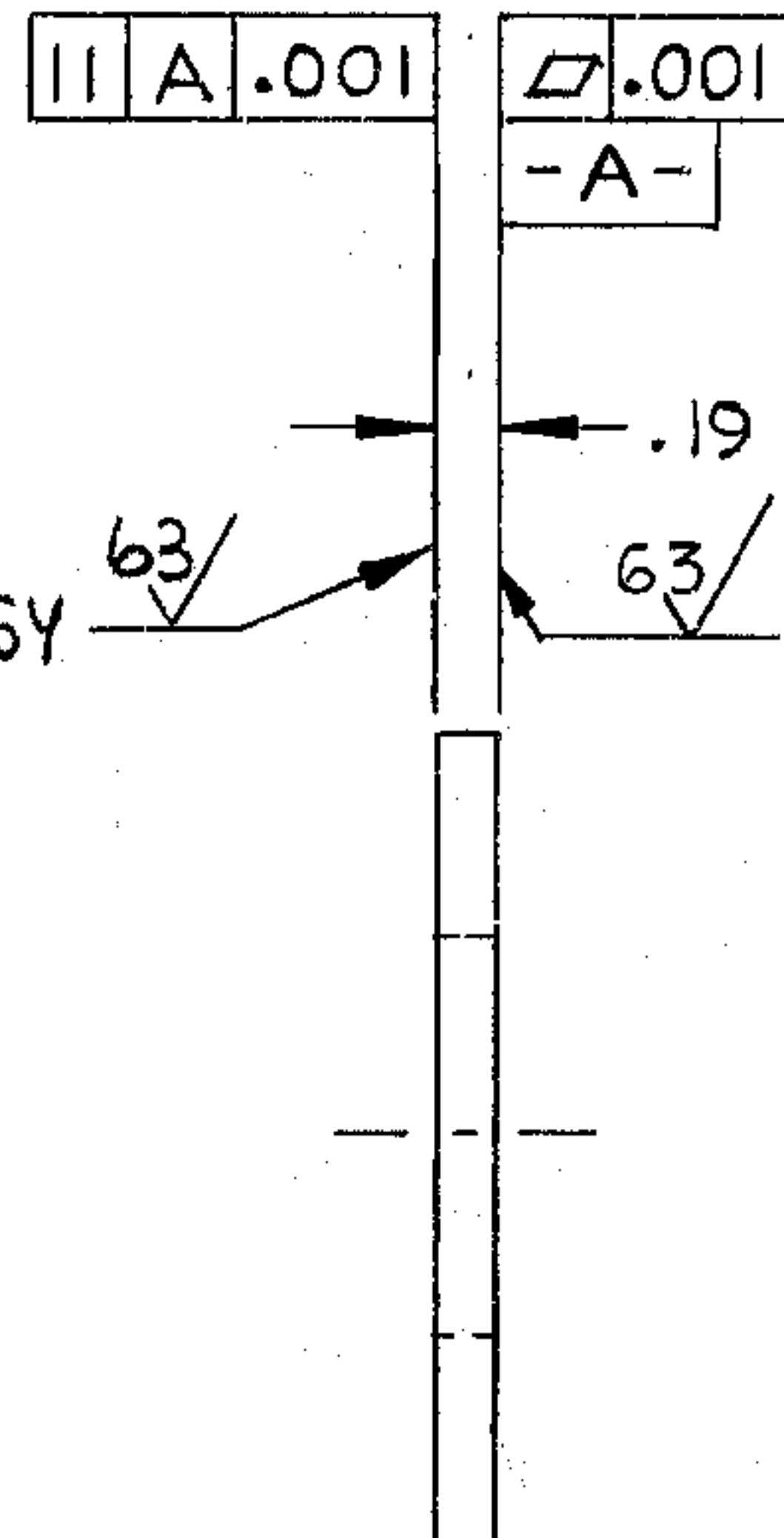

NOTES: UNLESS OTHERWISE SPECIFIED:

- 1.- ALL DIMENSIONS ARE IN INCHES.
- 2.- INTERPERET DIMENSIONING & TOLERANCING PER USA STANDARD USAS1-Y14.5-1966.
- 3.- SURFACE ROUGHNESS 250/ ALL OVER PER USA STANDARD USAS-B46.1-1962.
- 4.- MATERIAL: STEEL PLATE, 4140, QQ-S-624.
- 5.- BAG AND IDENTIFY WITH PN: 2150.300B019.

NEXT ASSY: 2150.300E002 (82402-44175R2)

REF. FILE 1181

LIMITS ON MACHINED DIMENSIONS EXCEPT AS NOTED ANGULAR ± 1° 0' LINEAR X = ± .1 JX = ± .03 XXX = ± .010 FRACTIONAL ± 1/32 BREAK ALL SHARP EDGES	150 IN. STELLAR TELESCOPE MTG		WESTERN HEAVY MACHINERY DIVISION GEAR CORPORATION EVERETT, WASHINGTON	
	DRAWN <i>L. Ogilvie</i> 7-17-69		SHIM —	
	CHECK <i>B, Sikli</i>		DRIVE GEARBOX	
	ENGR		SIZE B	CODE IDENT NO. 16603
APPROVED <i>[Signature]</i>		82402-44175C19		2150.300B019
SCALE 1 / 1		WT. — LB		SHEET 1 OF 1

REV

44175C19