

THIS DOCUMENT CONTAINS INFORMATION PROPRIETARY TO WESTERN GEAR CORPORATION. ALL DESIGN, MANUFACTURING, REPRODUCTION, USE, PATENT, AND SALES RIGHTS REGARDING THE SAME ARE HEREBY EXPRESSLY RESERVED BY WESTERN GEAR CORPORATION. THIS DOCUMENT IS SUBMITTED FOR REFERENCE PURPOSES ONLY AND SHALL NOT BE DISCLOSED TO ANY UNAUTHORIZED PERSON OR INCORPORATED INTO ANY OTHER PROJECT.

CHEM ETCH OR VIBRO SCRIBE  
PART NO. FAR SIDE:  
2150.300B018

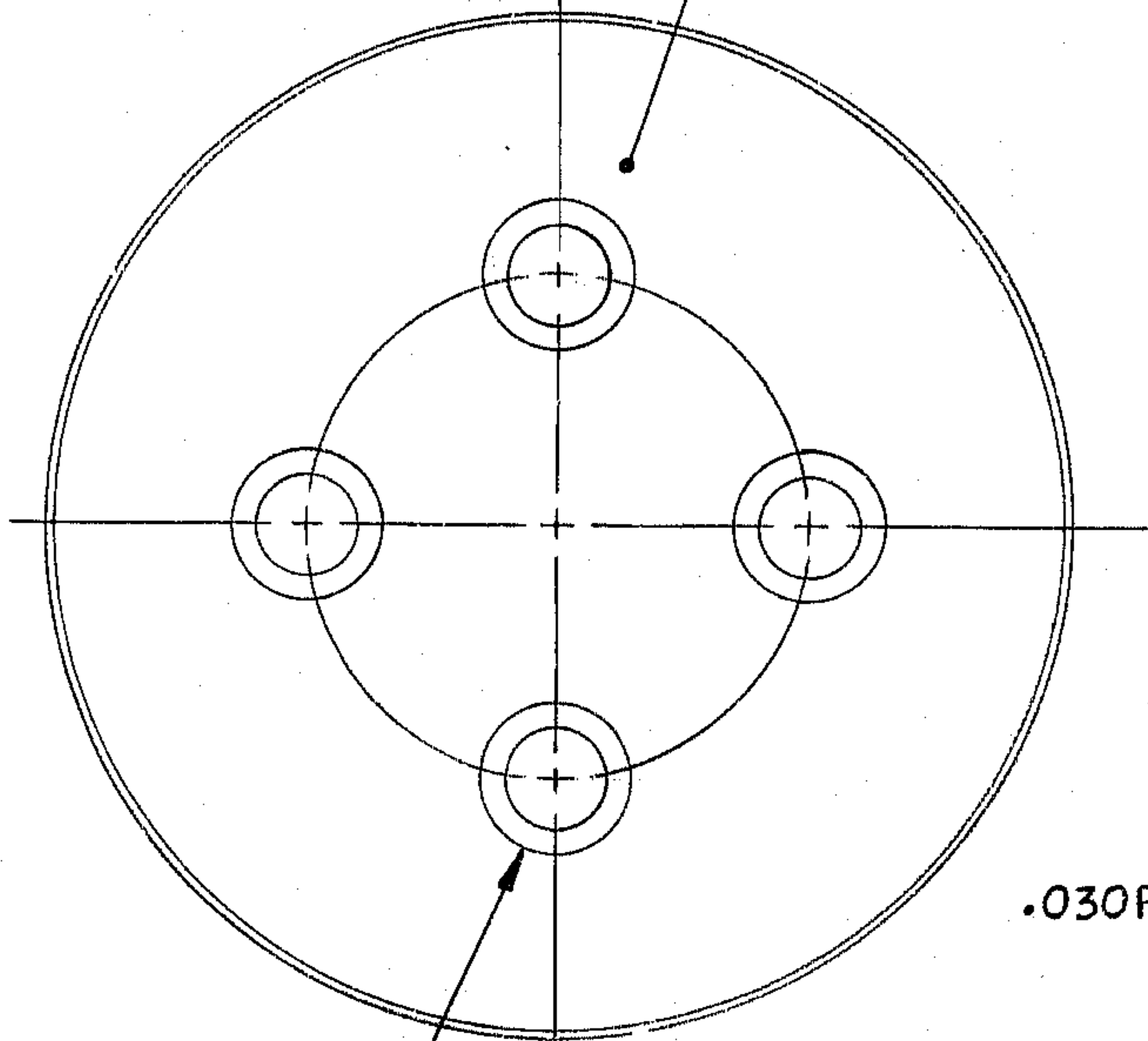

.560  
.575 DIA-THRU  
.812 CBORE - .53 DEEP  
.830  
4 HOLES EQL SP  
ON 2.500 DIA BSC  
⊕ A .030 DIA

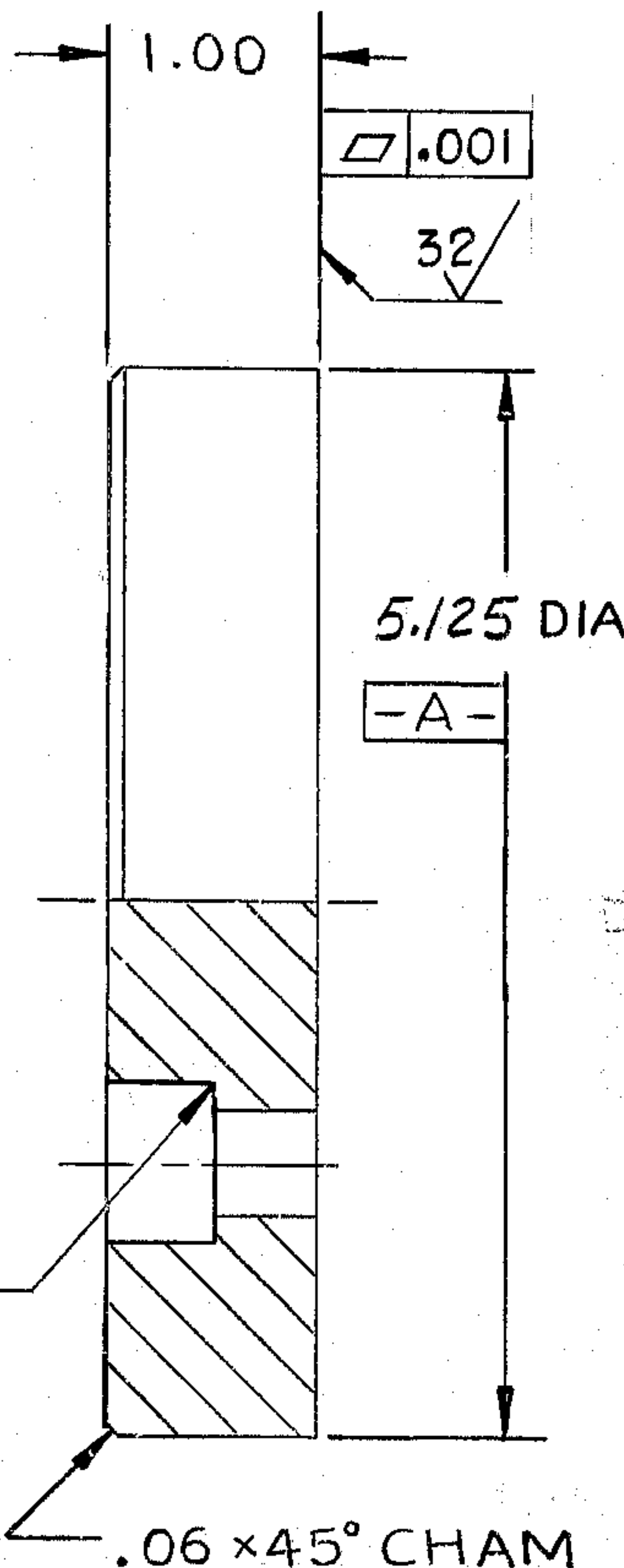

.030R TYP

.06 x 45° CHAM

NEXT ASSY: 2150.300E002(82402-44175R2)

NOTES: UNLESS OTHERWISE SPECIFIED:

- 1.- ALL DIMENSIONS ARE IN INCHES.
- 2.- INTERPRET DIMENSIONING & TOLERANCING PER USA STANDARD USAS1-Y14.5-1966.
- 3.- SURFACE ROUGHNESS 250/ ALL OVER PER USA STANDARD USAS-B46.1-1962.
- 4.- MATERIAL: STEEL BAR, 4140, QQ-S-624.

REVISIONS				
ZONE	LTR	DESCRIPTION	DATE	APPROVED

REF. 1181

LIMITS ON MACHINED DIMENSIONS EXCEPT AS NOTED ANGULAR ± 1° LINEAR X = ± .1 XX = ± .03 XXX = ± .010 FRACTIONAL ± 1/32  BREAK ALL SHARP EDGES	150 IN. STELLAR TELESCOPE MTG	<b>WESTERN</b> GEAR CORPORATION HEAVY MACHINERY DIVISION EVERETT, WASHINGTON
	82402-44175C18	
APPROVED <i>[Signature]</i>	SIZE <b>B</b>	CODE IDENT NO. <b>16603</b>
REV <i>[Symbol]</i>	SCALE   /	WT. — LB SHEET   OF
		2150.300B018

44175C18