

REVISIONS				
ZONE	L/R	DESCRIPTION	DATE	APPROVED
A		REVISED PER AURAL APP PRINT	7/23/63	
FS	A	5% DIA WAS 5/16 (3.000) DIA WAS 5/16	7/23/63	
GS	B	ADDED NOTE: STAMP PART # 2150.289E005	7/23/63	
		ADDED [1 A .003] & [2 .030 DIA]		
GS	C	ADDED 3/8 X 45° CHAM.	8-4-63	JW
DA	D	ADD 1 1/8" DIM FOR KPND ONLY	8-7-63	
FS	E	ADDED 3/8-45° AS BUILT	8-7-63	
		ADDED TOL TO 12% .5, 1.5% DIM	12-2-63	LLS

MATERIAL LIST				
PC NO	QTY	DESCRIPTION	MATL & SPEC	POURANT
1	1	R 1 1/2 DIA X 1	ASTM A36	29
2	2	R 1 1/2 X 3/8 X 12	ASTM A36	17
3	2	BAR 5 X 2 1/2 X 12	ASTM A36	33
4	1	R 1 1/2 DIA X 1/2	ASTM A36	14
5	AR	LEAD	94% LEAD 6% ANTIMONY	430

- NOTES:
1. ALL DIMENSIONS ARE IN INCHES
 2. FABRICATION TOLERANCES, EXCEPT AS NOTED
UP TO 10 INCHES = ± 1/16
10 TO 50 INCHES = ± 1/8
50 INCHES & OVER = ± 1/4
 3. WELD PER W.G.C SPECIFICATION TSZ, APPENDIX T1
 4. STRESS RELIEVE AFTER WELDING & BEFORE MACHINING PER W.G.C SPECIFICATION S10
 5. APPLY ONE COAT OF PRIME PAINT ALL OVER PER W.G.C SPECIFICATION S11 IMMEDIATELY AFTER STRESS RELIEVING & CLEANING & CASTING LEAD [2]
 6. CAST LEAD INTO FABRICATION AFTER STRESS RELIEVING & CLEANING & BEFORE PAINTING
 7. ALL SURFACES MARKED ✓ ARE TO BE [2] UNLESS OTHERWISE SPECIFIED

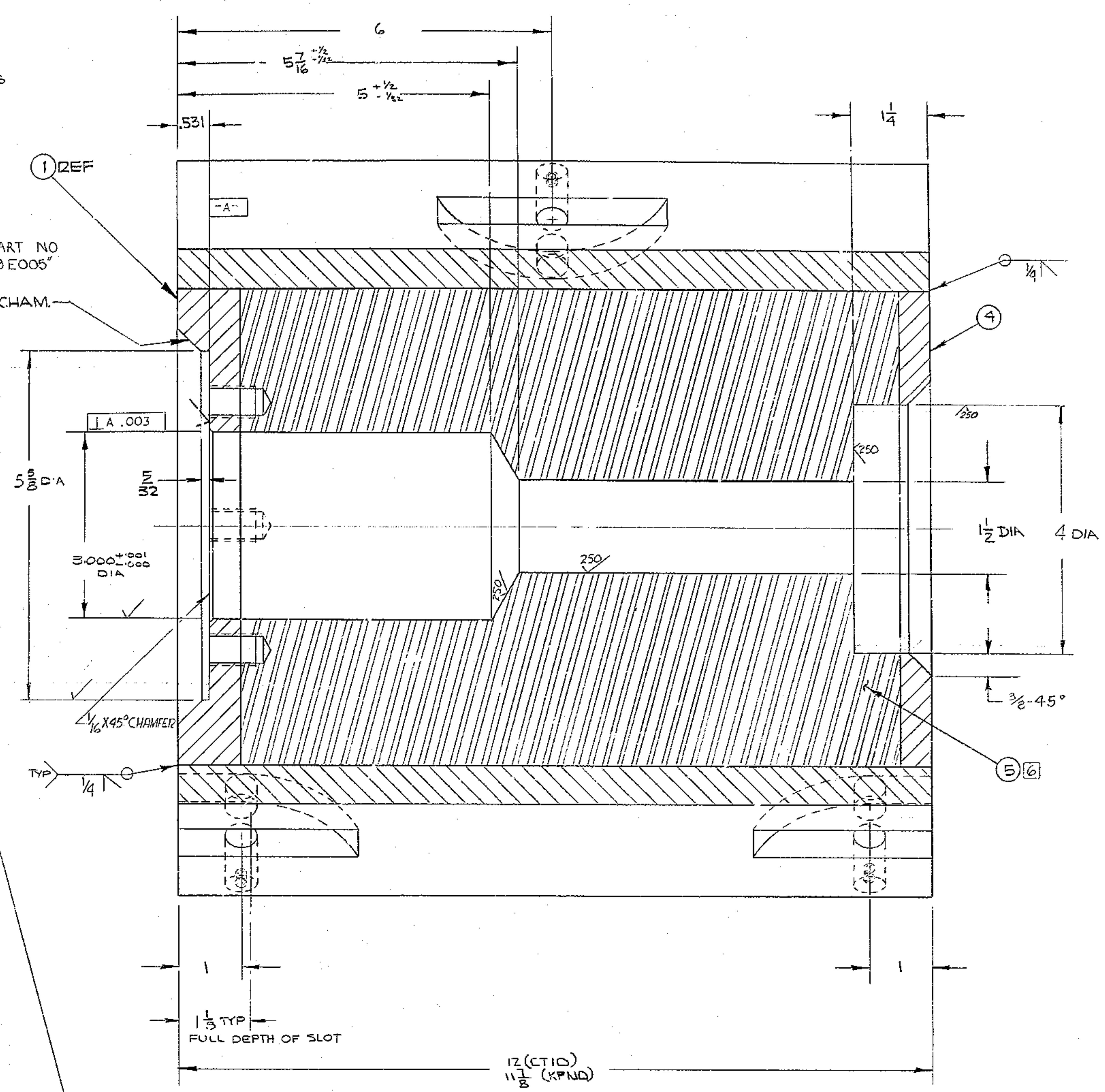
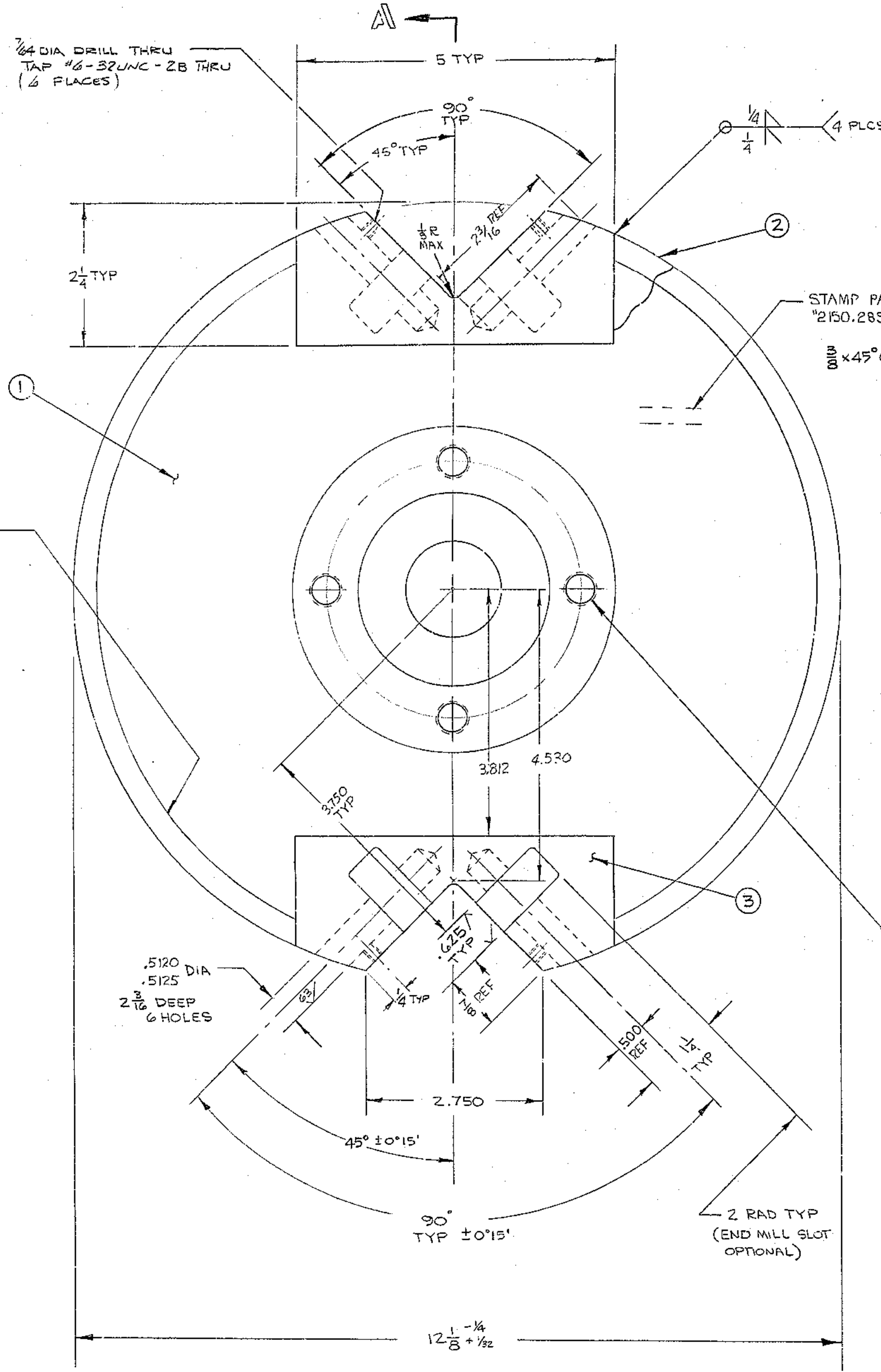

SECTION A-A

27/64 DRILL X 7/8 DEEP
TAP 1/2-13 UNC-2B X 7/8 DEEP 4 HOLES
EQUALLY SPACED ON 4.000 DIA CIRCLE
[2] .030 DIA

WESTERN GEAR CORPORATION
CONSTRUCTION PROJECTS
DEPARTMENT
APPROVED FOR
PROCUREMENT
DATE 9-22-63

NEXT ASSEMBLY: 2150.289E 002 (W.G.N 102 991)

FIND NO.	PART NO.	DESCRIPTION	QTY	MATERIAL	CODE IDENT
LIMITS ON MACHINED DIMENSIONS EXCEPT AS NOTED					
ANGULAR = ± 1' 0"					
LINEAR: X = ± .01 XXX = ± .010					
XX = ± .03 FRACTIONAL = ± 1/32					
BREAK ALL SHARP EDGES					
MATERIAL					
SEE MATERIAL LIST					
APPROVED					
LIST OF MATERIAL (LM)					
150 ^{LB} STELLAR TELESCOPE MOUNTING					
DRAWN: <i>Buffum</i> 5/29/63					
CHECK: <i>GR</i> 8/26/63					
ENGR					
WESTERN GEAR CORPORATION HEAVY MACHINERY DIVISION EVERETT, WASHINGTON					
WEIGHT -					
DEC AXIS COUNTERWEIGHT					
W.G.N 103 065					
SIZE CODE IDENT NO. E 16603 2150.289E 003					
SCALE 1/1 WT 527 LB SHEET 1 OF 1					