

5

4

3

2

1

REVISIONS				
ZONE	LTR	DESCRIPTION	DATE	APPROVED
	A	NEW DRAWING	9/28/68	
	B	NOTE 2: STAMP WAS TAG-ADDED 079	1/24/69	
	C	2 WAS 2 5/8, 2 3/4 WAS 2.687	3-13-71	JW
	D	1.187 WAS 1.570 <small>AREA NO. L5 A 5 2150, 289 B 079</small>	4-17-72	

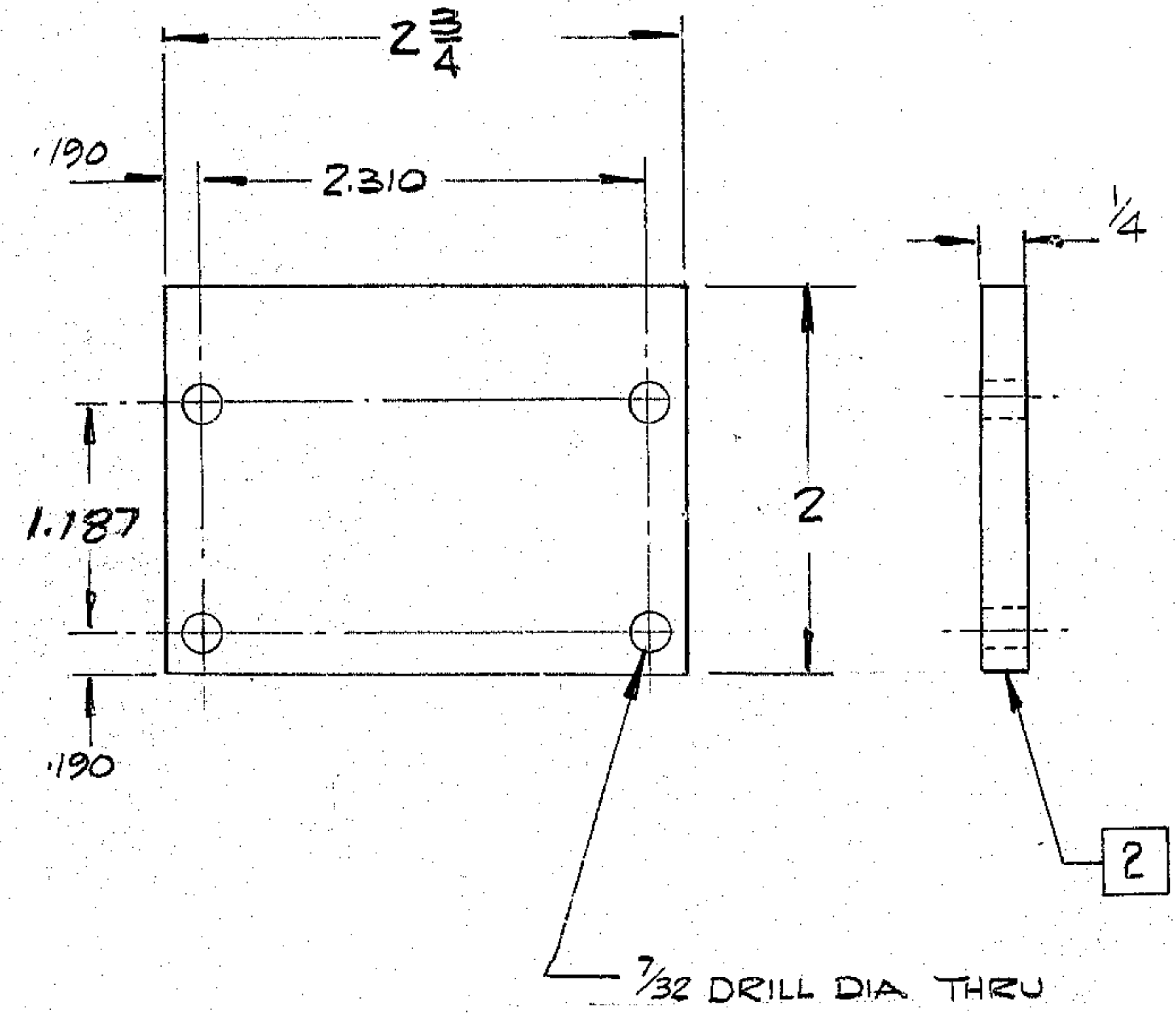

NOTES

1. ALL DIMENSIONS ARE IN INCHES.
2. STAMP PART NO 2150.289B.079
3. MATL STL C 1018.  
FLAT BAR 1/4 x 2 x 2 3/4

WESTERN GEAR CORPORATION  
 CONSTRUCTION PROJECTS  
 DEPARTMENT  
**APPROVED FOR  
 PROCUREMENT**

GR. DATE SEP 29 1968

REF. FILE 1179

LIMITS ON MACHINED DIMENSIONS EXCEPT AS NOTED  
 ANGULAR ± 1° 0'  
 LINEAR  
 .X = ± .1  
 .XX = ± .03  
 .XXX = ± .010  
 FRACTIONAL ± 1/32  
 BREAK ALL SHARP EDGES

150" STELLAR TELESCOPE MFG  
 DRAWN J. LYDSTER  
 CHECK P. GREFE  
 ENGR  
 W.G. C112681  
 APPROVED

**Western GEAR CORPORATION** HEAVY MACHINERY DIVISION  
 EVERETT, WASHINGTON

LIMIT SWITCH MOUNTING PLATE (DEC AXIS C/WEIGHT)

SIZE	CODE IDENT NO.	REV
B	16603 2150.289B020	D

SCALE 1/1 WT. LB SHEET 1 OF 1