

5

4

3

2

1

REVISIONS				
ZONE	LTR	DESCRIPTION	DATE	APPROVED
	A	REVISED PER AURA APP PRINT	9/27/68	
	B	ADDED NOTE #4	1/10/69	

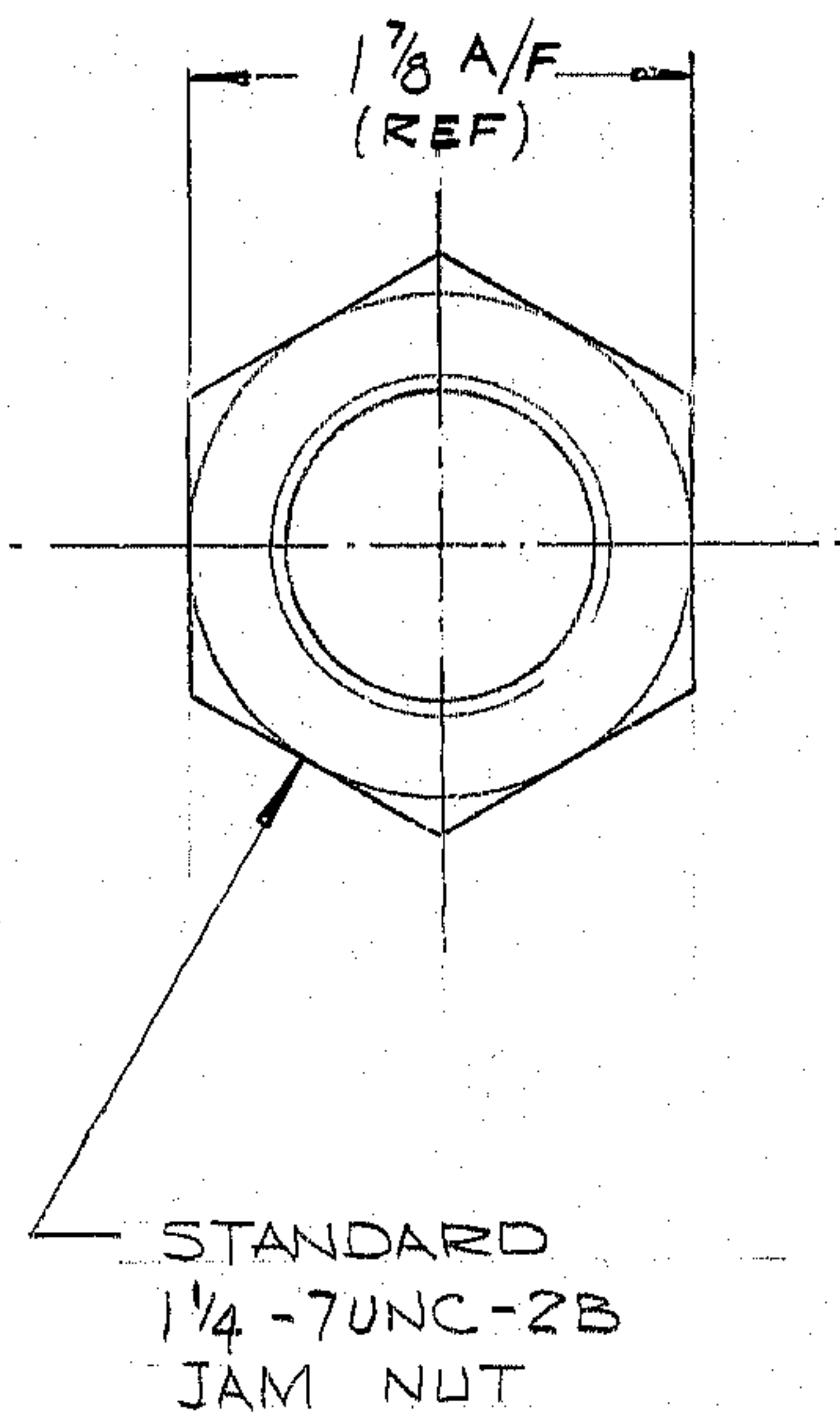
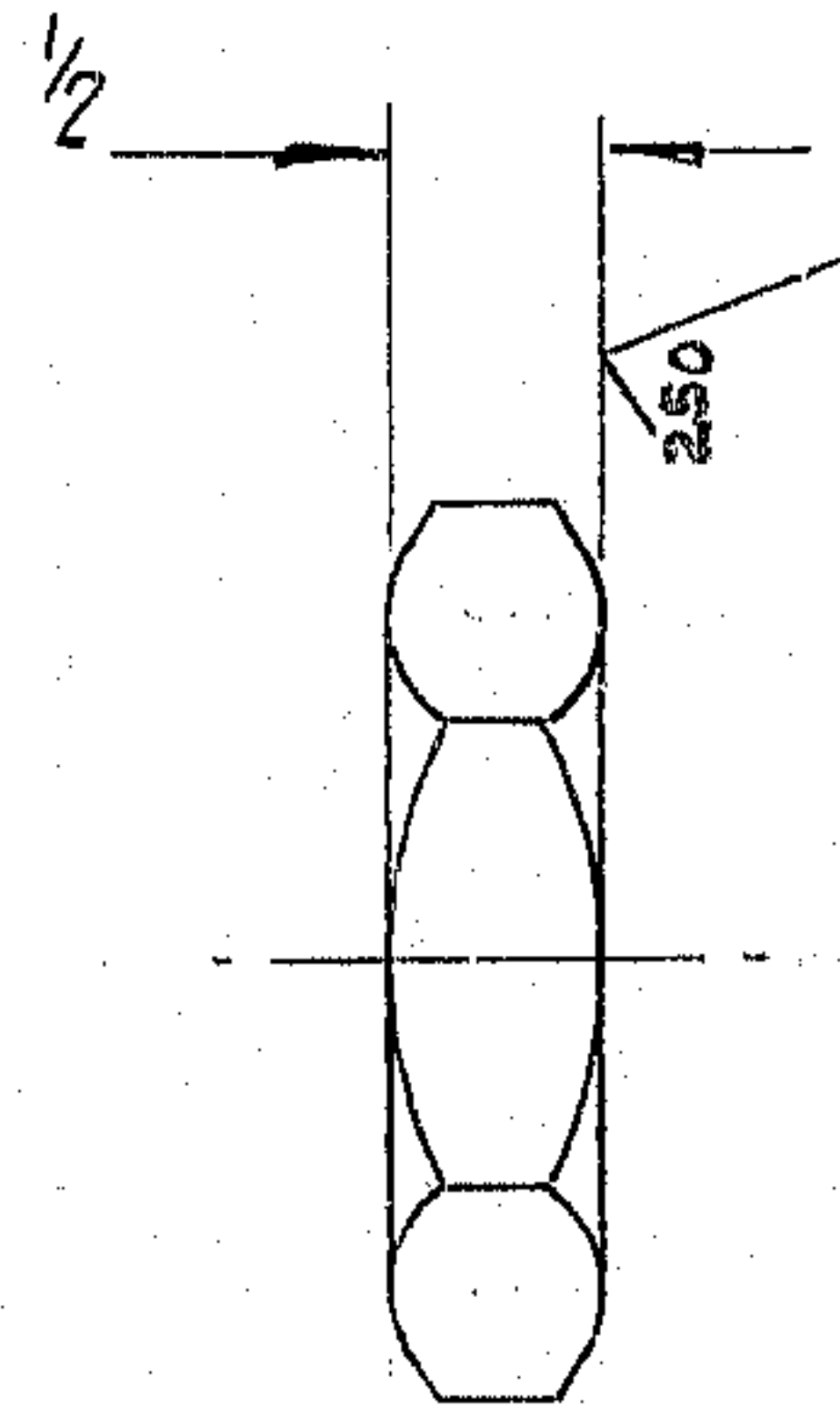

NOTES

- ALL DIMENSIONS ARE IN INCHES
- MAT: - STL MAKE FROM STANDARD 1/4-7UNC-2B JAM NUT
- TAG WITH PART NO 2150-289B018
- CAD PLATE ALL OVER .0003 THICK MAX.

REF.
1179

NEXT ASSEMBLY 2150.289 E002 (WGN 102991)

LIMITS ON MACHINED DIMENSIONS EXCEPT AS NOTED ANGULAR ± 1° 0' LINEAR .X = ± .1 .XX = ± .03 .XXX = ± .010 FRACTIONAL ± 1/32 BREAK ALL SHARP EDGES	150 ^{IN} STELLAR.	Western GEAR CORPORATION		HEAVY MACHINERY DIVISION EVERETT, WASHINGTON	
	TELESCOPE MTG	JAM NUT, MODIFIED DEC AXIS COUNTERWEIGHT.			
	DRAWN J. LYDSTER.	SIZE B	CODE IDENT NO. 16603	2150.289B018	REV B
	CHECK P. GREFE	SCALE 1/1	WT.	LB	SHEET 1 OF 1
	ENGR				
	W.G.C 112685				
	APPROVED				

WESTERN GEAR CORPORATION
 CONSTRUCTION PROJECTS
 DEPARTMENT
APPROVED FOR PROCUREMENT
 G.R. DATE 9-29-68