

5

4

3

2

1

REVISIONS				
ZONE	LTR	DESCRIPTION	DATE	APPROVED
	A	REVISED PER AURA APP PRINT	9/24/68	
	B	ADDED 250/ FIN. MARKS # "OR EQUIV" # TO NOTE 2	1/24/69	

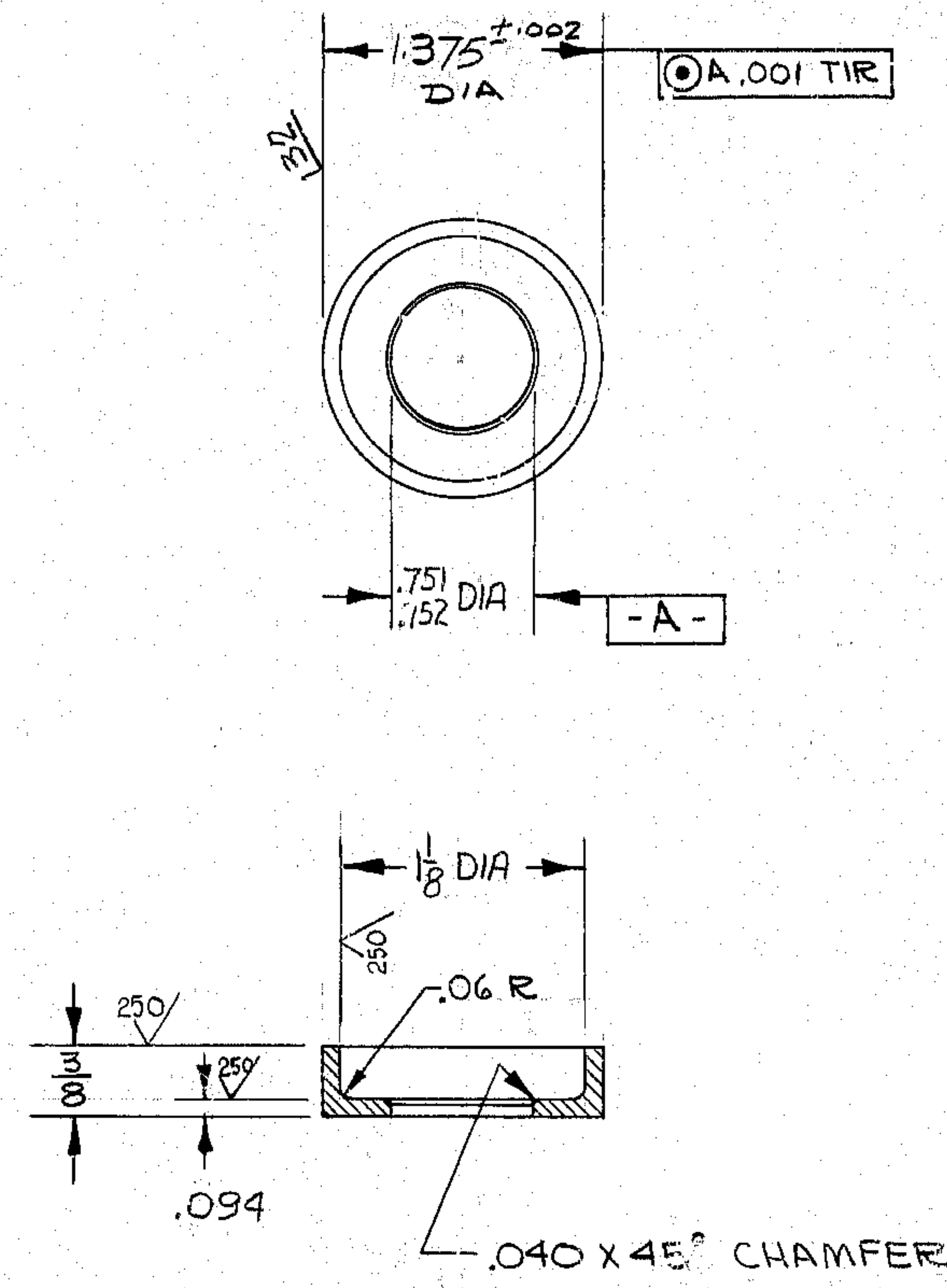

NOTES :

1. ALL DIMENSIONS ARE IN INCHES
2. MATERIAL : AISI C-1018 1/2 DIA X 5/8 LONG. OR EQUIV.
3. FINISH MACHINE 125/ ALL OVER UNLESS OTHERWISE SPECIFIED
4. TAG PART NO "2150.289 B012"

REF. 1179

WESTERN GEAR CORPORATION
 CONSTRUCTION PROJECTS
 DEPARTMENT
 APPROVED FOR
 PROCUREMENT

NEXT ASSEMBLY 2150.289E002 (W.G.N 10Z991)

LIMITS ON MACHINED DIMENSIONS EXCEPT AS NOTED ANGULAR ± 1° 0' LINEAR .X = ± .1 .XX = ± .03 .XXX = ± .010 FRACTIONAL ± 1/32 BREAK ALL SHARP EDGES	150 IN STELLAR TELESCOPE MOUNTING		Western GEAR CORPORATION HEAVY MACHINERY DIVISION EVERETT, WASHINGTON	
	DRAWN <i>B. Griffin</i> 6/8/68		ADAPTER, SEAL -	
	CHECK GR 20 AUG 68		DEC AXIS COUNTERWEIGHT	
	ENGR			
W.G.C 112638		SIZE B	CODE IDENT NO. 16603	2150.289B012
APPROVED		SCALE 1/1	WT.	LB SHEET 1 OF 1

G.R. DATE 9-29-68