

5

4

3

2

1

REVISIONS				
ZONE	LTR	DESCRIPTION	DATE	APPROVED
	A	REVISED PER AURA APP PRINT	9/24/68	

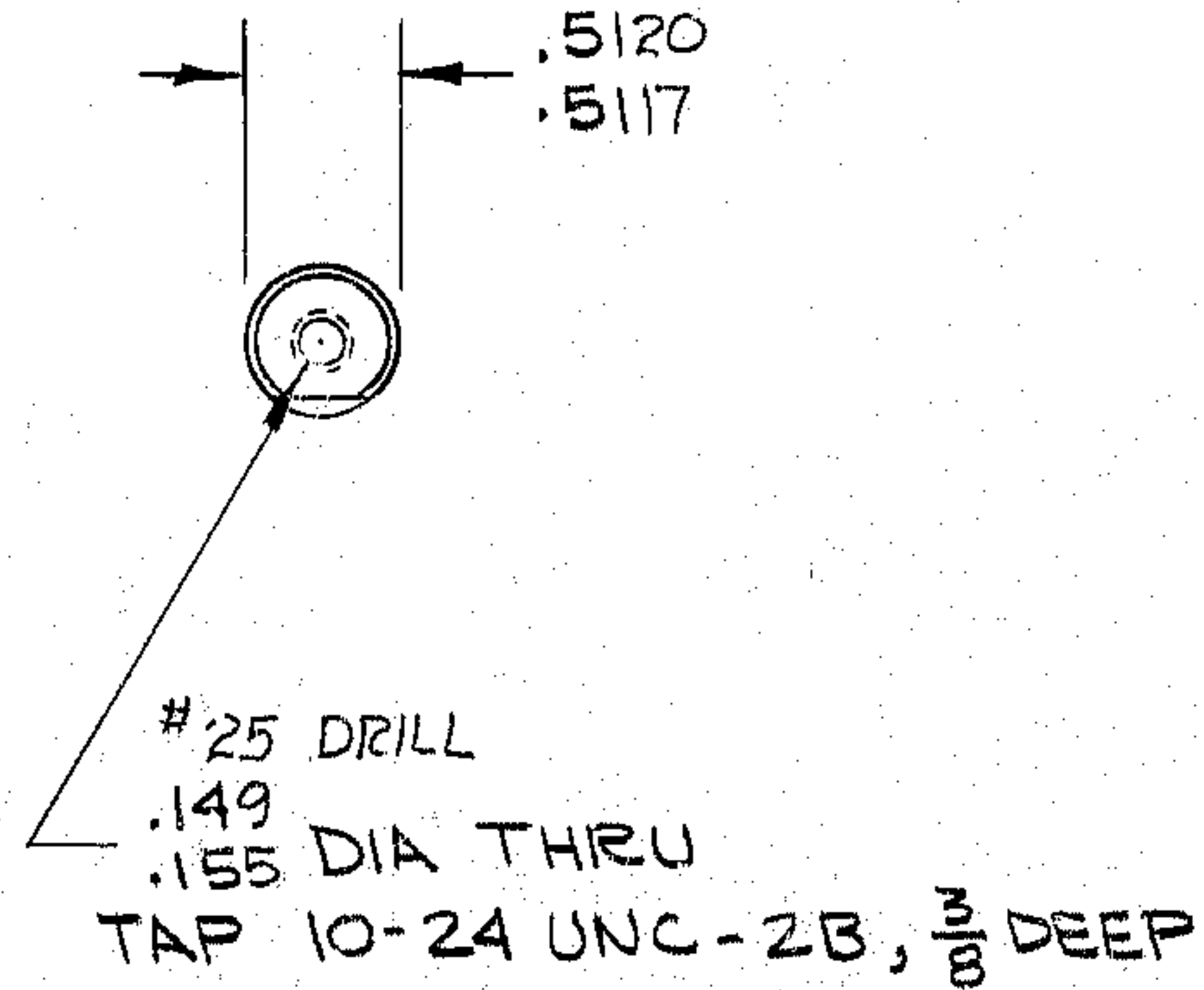
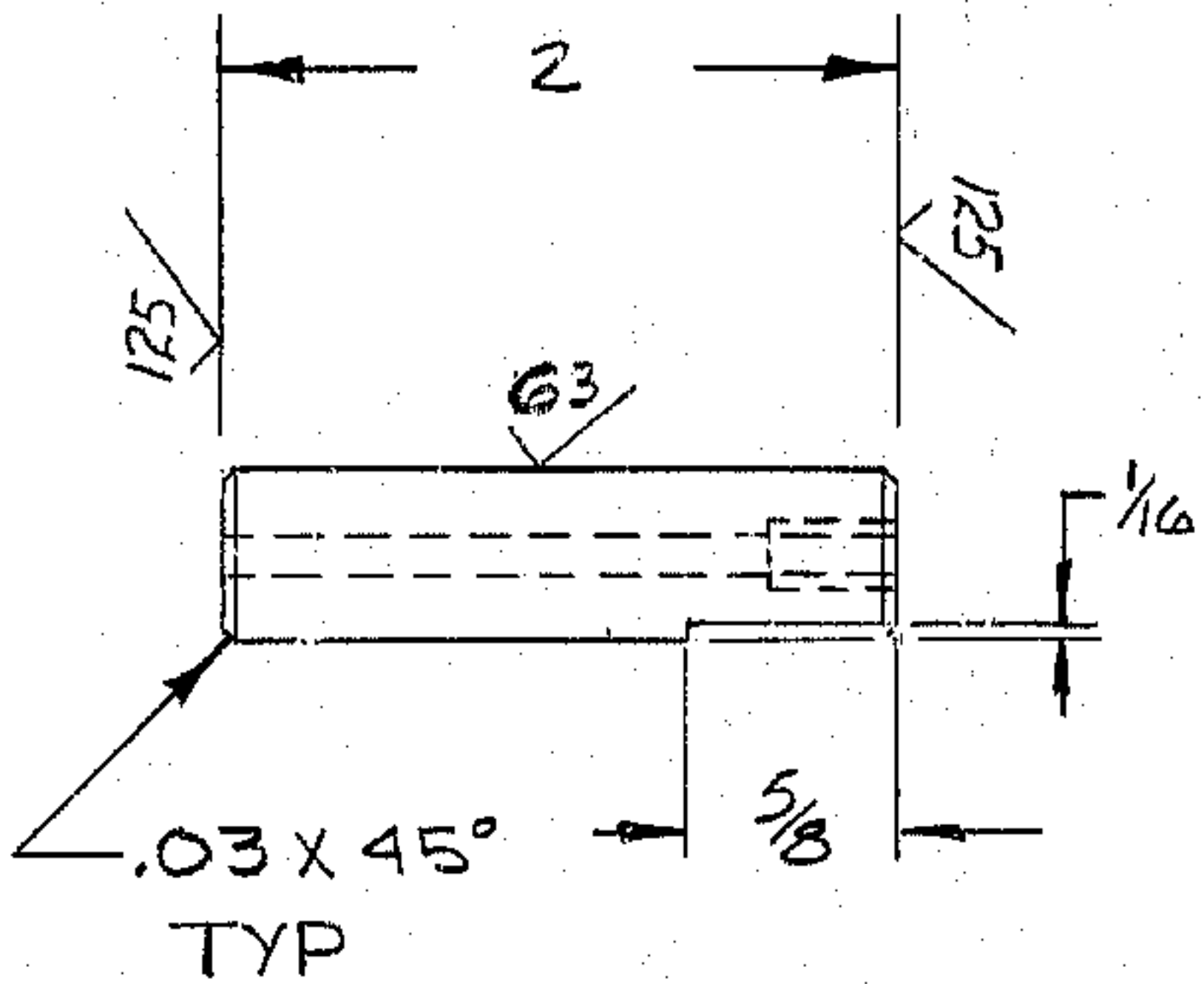

NOTES:
 1. ALL DIMENSIONS ARE IN INCHES
 2. MATERIAL: 5/8 DIA X 2 1/4 LG BAR AISI 61018 STL

REF. FILE 1179

WESTERN GEAR CORPORATION
 CONSTRUCTION PROJECTS
 DEPARTMENT
**APPROVED FOR
 PROCUREMENT**
 G.R. DATE 9-22-68

NEXT ASSEMBLY 2150.289E002 (WGN102991)

LIMITS ON MACHINED DIMENSIONS EXCEPT AS NOTED ANGULAR ± 1° 0' LINEAR .X = ± .1 .XX = ± .03 .XXX = ± .010 FRACTIONAL ± 1/32 BREAK ALL SHARP EDGES	150 ^{IN} STELLAR TELESCOPE MOUNT		Western GEAR CORPORATION HEAVY MACHINERY DIVISION EVERETT, WASHINGTON	
	DRAWN <i>B. Buffen</i>		SHAFT, BEARING -	
	CHECK <i>GR 20 AUG 68</i>		DEC AXIS COUNTERWEIGHT	
	ENGR			
W.G.C 112 634		SIZE B	CODE IDENT NO. 16603 2150.289B011	REV A
APPROVED		SCALE 1/1	WT.	LB SHEET 1 OF 1