

4

3

2

1

REVISIONS				
ZONE	LTR	DESCRIPTION	DATE	APPROVED
A		REVISED PER AURA APPROVED PRINT	3/6/69	<i>Wda/ll</i>

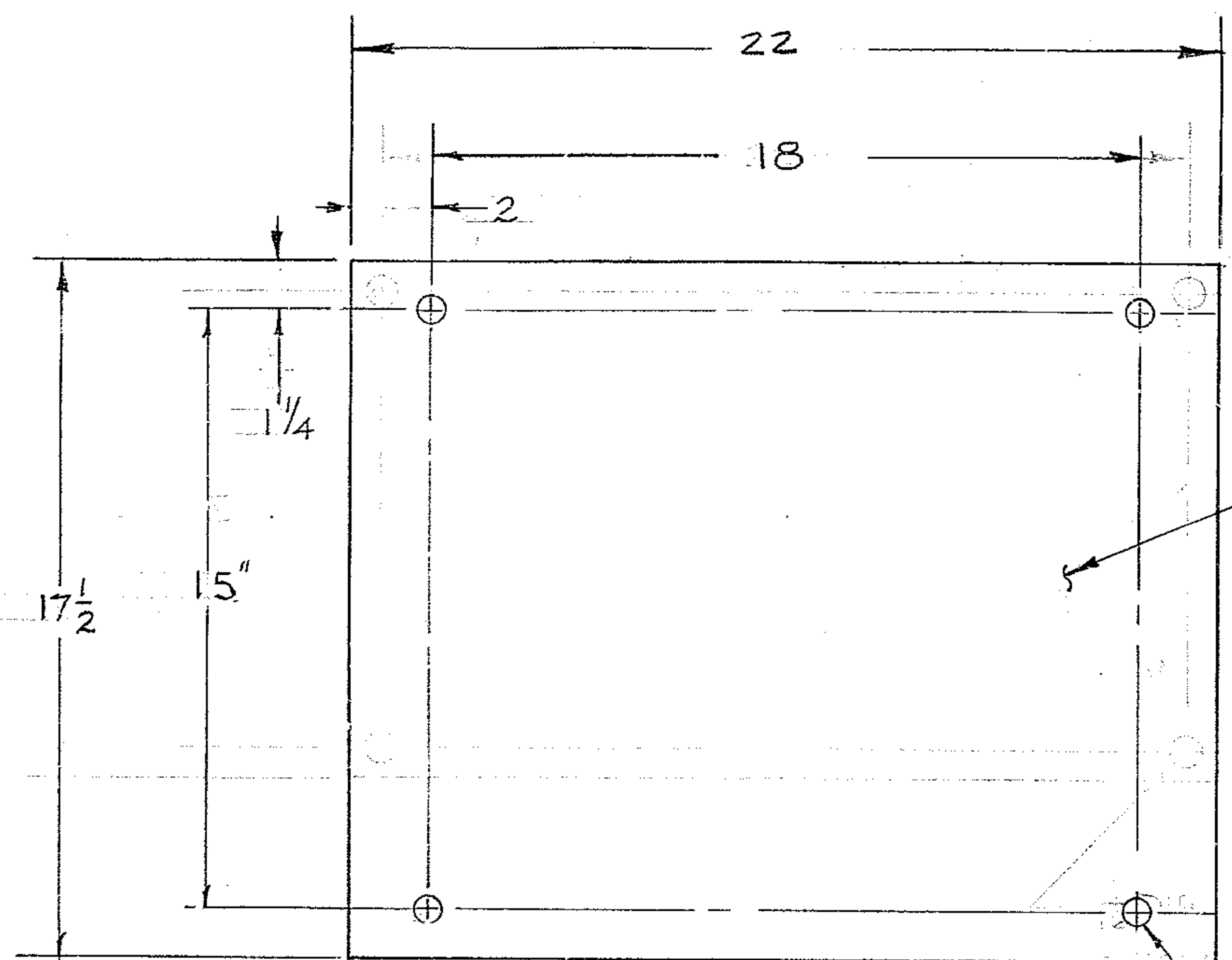

STAMP
PART NO.
2150.287C006

NOTES:
1. ALL DIMENSIONS ARE IN INCHES

$\frac{3}{8}$ STOCK

$\frac{11}{16}$ DIA.
4 HOLES

REF. FILE 1178

NEXT ASSEMBLY 2150.287E002 (WGN 103032)

WESTERN GEAR CORPORATION
CONSTRUCTION PROJECTS
DEPARTMENT
APPROVED FOR
PROCUREMENT
C Russo DATE 11/24/69

FIND NO.	PART NO.	DESCRIPTION	QTY	MATERIAL	CODE IDENT
LIST OF MATERIAL (LM)					
LIMITS ON MACHINED DIMENSIONS EXCEPT AS NOTED ANGULAR = $\pm 1^{\circ} 0'$ LINEAR: X = $\pm .1$.XXX = $\pm .010$.XX = $\pm .03$ FRACTIONAL = $\pm 1/32$		150 ^{IN} STELLAR TELESCOPE MOUNTING-		Western GEAR CORPORATION	HEAVY MACHINERY DIVISION EVERETT, WASHINGTON
BREAK ALL SHARP EDGES		DRAWN <i>B. Buffkin</i> 5/1/68 CHECK <i>J. Paisley</i> 5-21-68 ENGR		WEIGHT - CASSEGRAIN CAGE SUPPORT ASSY	
MATERIAL $\frac{3}{8}$ SHT, ANTIMONIAL LEAD. 6% ANTIMONY, .391 LBS IN ³		WGD 107505		SCALE $\frac{1}{4}$	WT LB SHEET 1 OF 1
		APPROVED		SIZE CODE IDENT NO. C 16603	REV 2150.287C006 A

D-107.505