

4

3

2

1

REVISIONS				
ZONE	LTR	DESCRIPTION	DATE	APPROVED
	A	REVISED PER AURA APPROVED PRINT	3/6/69	lw/08

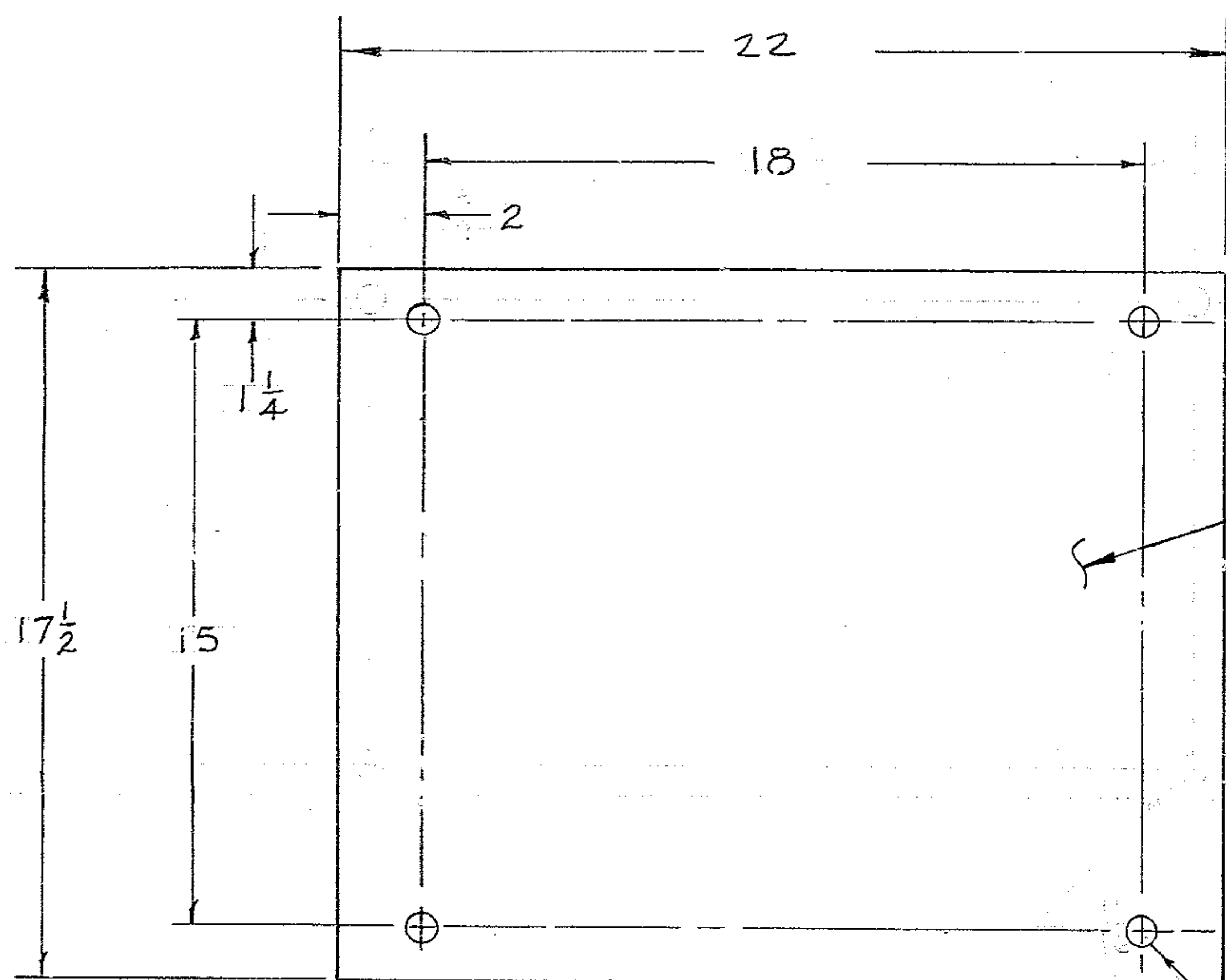

STAMP  
PART NO.  
2150.287C005

NOTES:  
1. ALL DIMENSIONS ARE IN INCHES

1/4 STOCK

11/16 DIA. 4 HOLES

R.F.  
FILE 1173

NEXT ASSEMBLY 2150.287E002 (WGN 103032)

WESTERN GEAR CORPORATION  
CONSTRUCTION PROJECTS  
DEPARTMENT  
APPROVED FOR  
PROCUREMENT  
  
G Russo DATE 11/24/69

FIND NO.	PART NO.	DESCRIPTION	QTY	MATERIAL	CODE IDENT
LIST OF MATERIAL (LM)					
LIMITS ON MACHINED DIMENSIONS EXCEPT AS NOTED ANGULAR = ± 1° 0'		150 IN STELLAR TELESCOPE MOUNTING		<b>Western GEAR CORPORATION</b> HEAVY MACHINERY DIVISION EVERETT, WASHINGTON	
LINEAR: X = ± .1    .XXX = ± .010 .XX = ± .03    FRACTIONAL = ± 1/32		DRAWN <i>B. Duffin</i> 5/1/68 CHECK <i>Op. Bradley</i> 5-21-68 ENGR		TOP PLATE, WEIGHT - CASSEGRAIN CAGE SUPPORT ASSY	
BREAK ALL SHARP EDGES		MATERIAL 1/4 PLATE, STL ASTM A-36 OR EQUIV.		WGD 107 506	
		APPROVED		SIZE <b>C</b>	CODE IDENT NO. <b>16603</b>
				WT	2150.287C005
				SCALE 1/4	REV <b>A</b>
				LB	SHEET 1 OF 1

D-107,506