

BILL OF MATERIAL

ITEM	QTY	MATERIAL	DESCRIPTION	WEIGHT
------	-----	----------	-------------	--------

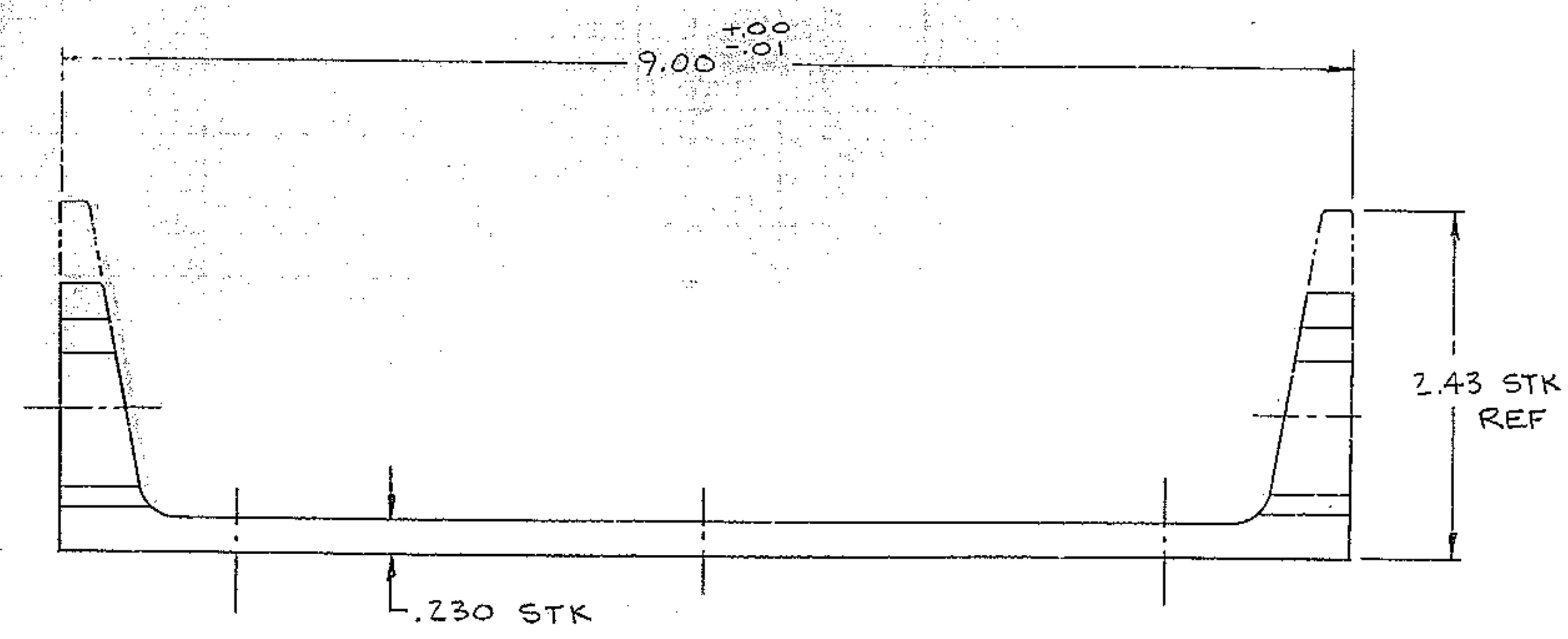
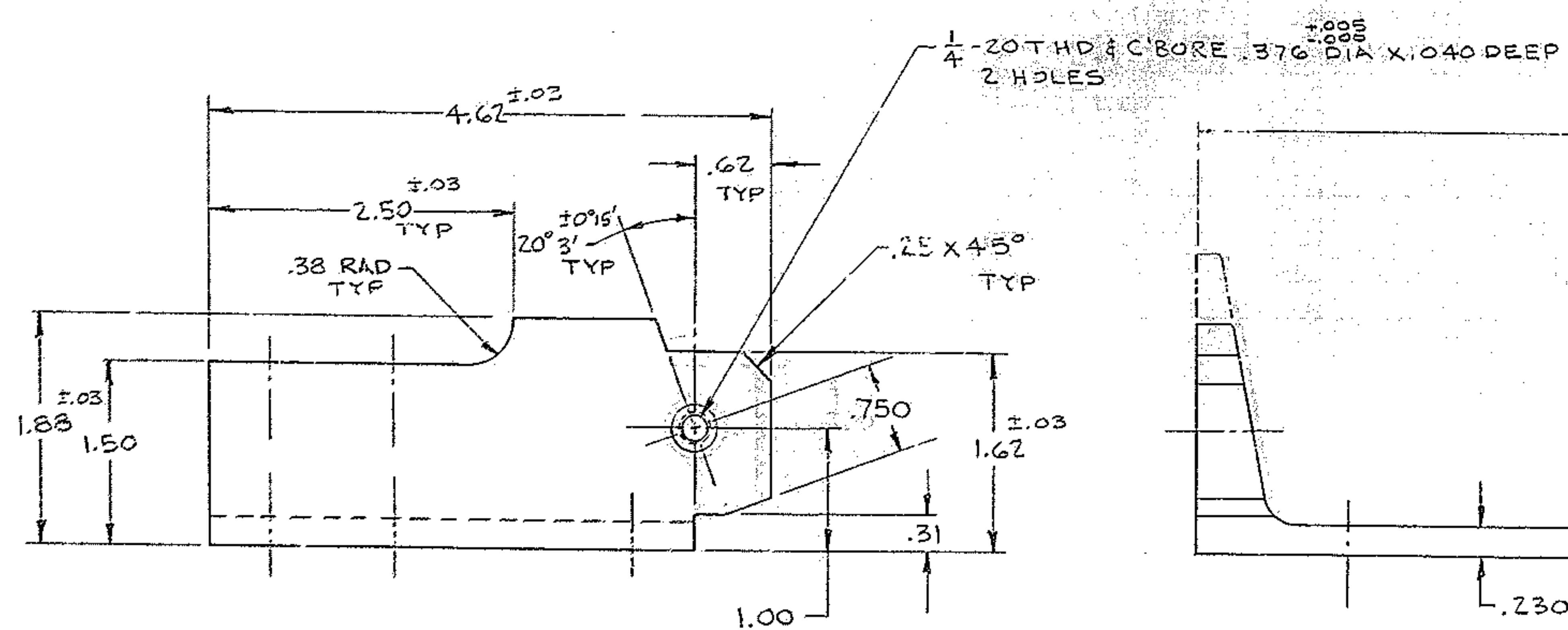
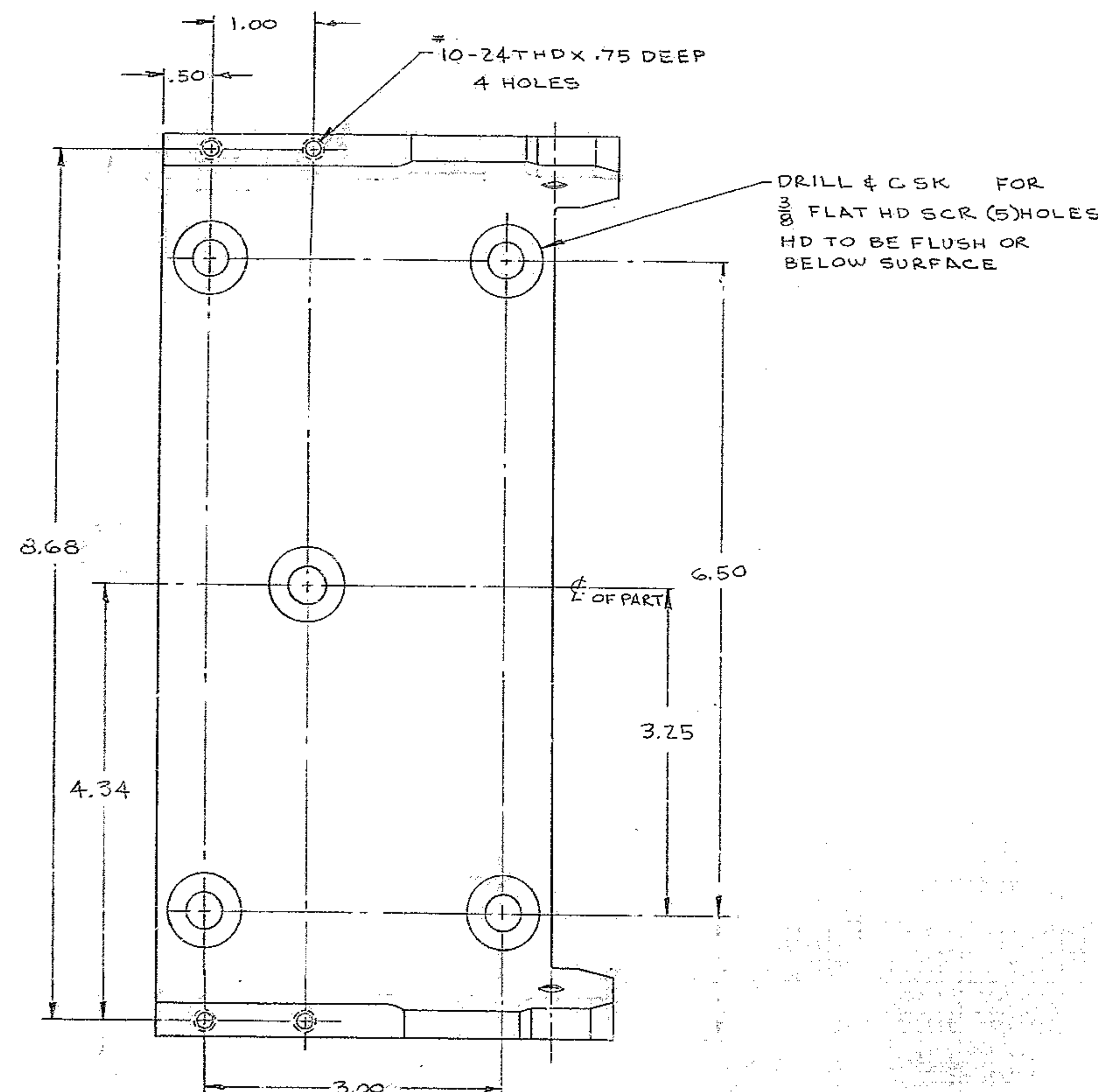

MAT'L: C 9 X 13.4 STEEL (SELECT FOR 9.00 DIM)
2 REQ'D, CD PLATE

6. DIM. APPLY AFTER PLATING.
5. BREAK SHARP EDGES .03
4. IDENTIFY BY _____ AT LOCATION _____ "MADE IN U.S.A."
3. STAMP MATCH MARKS ON ALL MATING PARTS WHERE NECESSARY.
2. PROJECT DRAWINGS _____
1. FOR NEXT ASSY. SEE 2150.284-E 202

KITT PEAK NATIONAL OBSERVATORY
OPERATED BY THE
ASSOCIATION OF UNIVERSITIES FOR RESEARCH IN ASTRONOMY, INC.
UNDER CONTRACT WITH
NATIONAL SCIENCE FOUNDATION

150" TELESCOPE REF. FILE 1177
NAME BRACKET, ANCHOR- SCALE FULL
E. DEC. CABLE WRAP-UP ASSY PRINT ISSUED

DESIGNED BY: M.B.H. DATE: 12-18-71 APPROVED BY: DATE: 12-18-71
DRAWN BY: DATE: 12-18-71 APPROVED BY: DATE: 12-18-71
CHECKED BY: R. CHADD. DATE: 2-3-72 APPROVED BY: E.G. DATE: 1-31-72

DRAWING NUMBER: 2150.284-D203 REV. A

LET.	REVISION	ECR	DATE	BY
A	REVISED DIMS FOR STK TO	0786	2-18-72	W.H. HBC