

REVISIONS				
ZONE	LTR	DESCRIPTION	DATE	APPROVED
A3	A	MATL LIST 40-45 SDH ADDED	11-9-68	
	A	REVISED PER SUPR APPD PRINT	"	

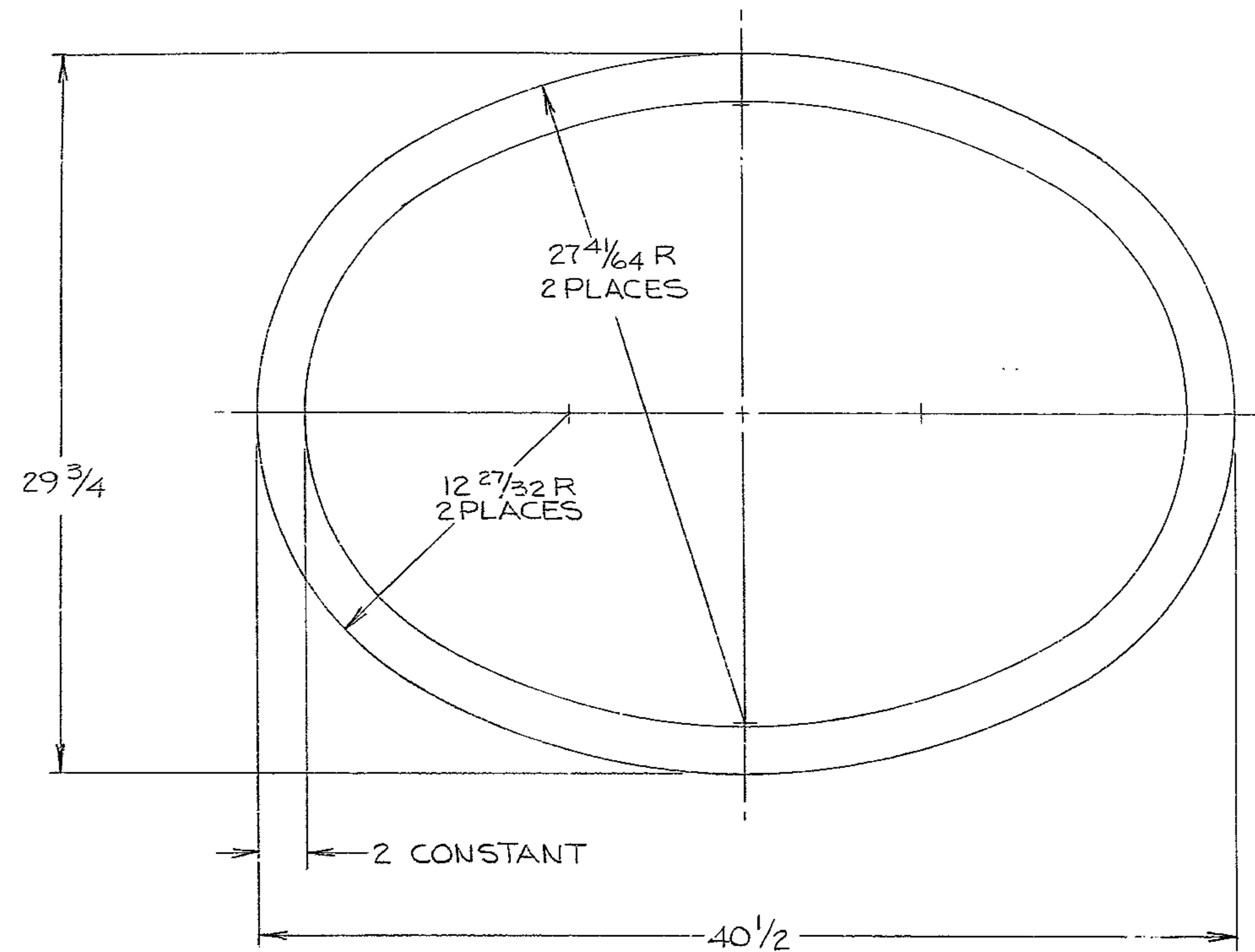

- NOTES:
- ALL DIMENSIONS ARE IN INCHES
 - FABRICATION TOLERANCES EXCEPT AS NOTED
 - UP TO 10 INCHES $1/16$
 - 10 TO 50 INCHES $1/8$

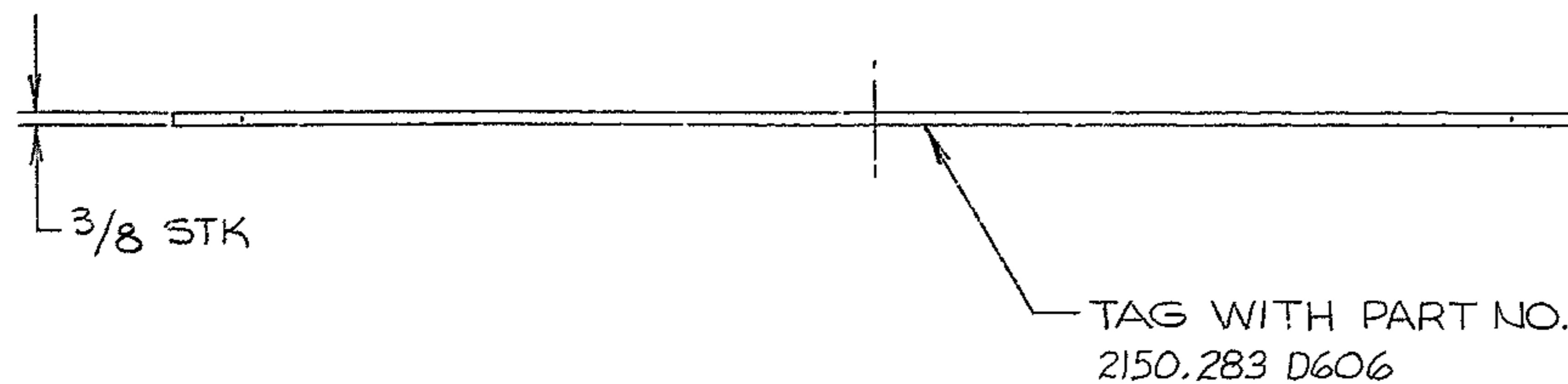

WESTERN GEAR CORPORATION
 CONSTRUCTION PROJECTS
 DEPARTMENT
 APPROVED FOR
 PROCUREMENT
 DATE 11/21/68

FIND NO.	PART NO.	DESCRIPTION	QTY	MATERIAL	CODE IDENT
LIST OF MATERIAL (LM)					
LIMITS ON MACHINED DIMENSIONS EXCEPT AS NOTED ANGULAR = ± 1° 0'		150 IN STELLAR TELESCOPE MOUNTING		western GEAR CORPORATION HEAVY MACHINERY DIVISION EVERETT, WASHINGTON	
LINEAR: X = ± .1 .XXX = ± .010 .XX = ± .03 FRACTIONAL = ± 1/32		DRAWN BIRKENDAHL 3/13/68 CHECK S. Munko 5/19/68		SEAL, COVER, MIRROR... COUDE #3 ASSY	
BREAK ALL SHARP EDGES		ENGR		MATERIAL	
NEOPRENE SHT 29 3/4 X 3/8 X 40 1/2 40-45 SDH		W.G.E 107,681		SIZE CODE IDENT NO. REV D 16603 2150.283 D606 A	
SCALE 1/4"		WT		LB SHEET 1 OF 1	

NEXT ASSY 2150.283 E 602 (W.G.N102,988)

REF FILE 1176