

REVISIONS				
ZONE	LTR	DESCRIPTION	DATE	APPROVED
	A	REDRAWN WITH REVISIONS PER AURA AP'D PRINT DRIVE WAS GLOBE TYPE	11/24/68	

2
 SPUR PINION
 28 TEETH
 14 1/2° P.A.
 12 D.P.
 2.333 P.D. REF.

SLIP CLUTCH
 HILLIARD #DL 4-1-322 A
 TORQUE RANGE 8-72 FT-LBS

NOTES:
 1, ALL DIMENSIONS ARE IN INCHES
 2, ALL SURFACES FINISHED WITH 31720
 BLACK VELVET, FINISH ENAMEL EXCEPT
 WHERE NOTED 2

REF. 1176

(W.G.N 102896)

NEXT ASSY: 2150.283E/01

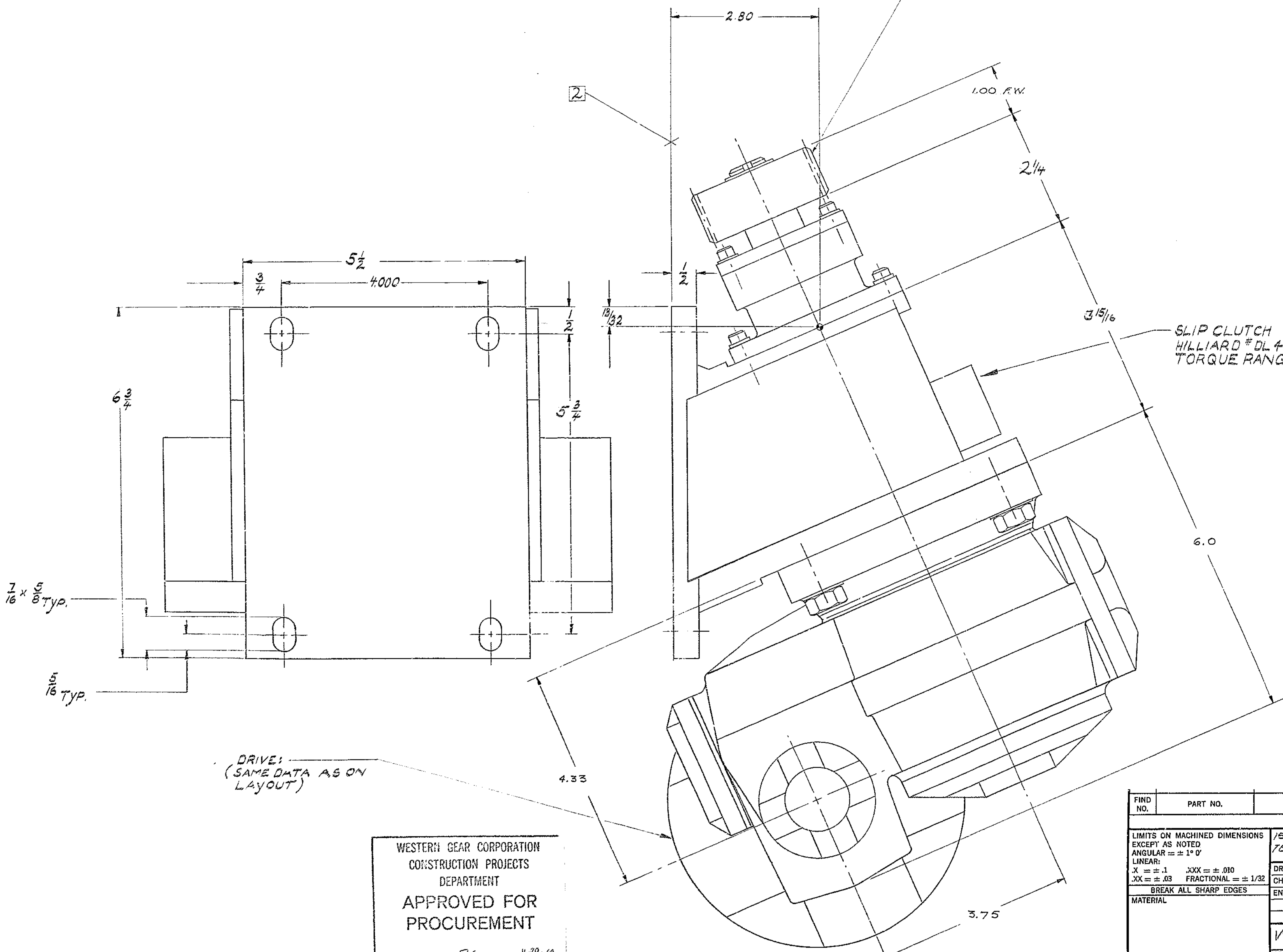

DRIVE:
 (SAME DATA AS ON
 LAYOUT)

WESTERN GEAR CORPORATION
 CONSTRUCTION PROJECTS
 DEPARTMENT
 APPROVED FOR
 PROCUREMENT
 P.G. DATE 4-29-68

FIND NO.	PART NO.	DESCRIPTION	QTY	MATERIAL	CODE IDENT
LIST OF MATERIAL (LM)					
LIMITS ON MACHINED DIMENSIONS EXCEPT AS NOTED		150m STELLAR	WESTERN GEAR CORPORATION HEAVY MACHINERY DIVISION EVERETT, WASHINGTON		
ANGULAR = ± 1° 0'		TELESCOPE MOUNTING			
LINEAR:		DRAWN BIRKENDAHL 5/11/68			
X = ± .1 XXX = ± .010		CHECK NICOLOAYS 5/18/68			
XX = ± .03 FRACTIONAL = ± 1/32		ENGR			
BREAK ALL SHARP EDGES					
MATERIAL					
		W.G.E. 107676	SIZE	CODE IDENT NO.	REV
		APPROVED	D	16603 2150.283D301	A
		SCALE FULL	WT	LB	SHEET / OF /