

4

3

2

1

REVISIONS				
ZONE	LTR	DESCRIPTION	DATE	APPROVED
A		RELEASED FOR MANUFACTURE	1/15/69	

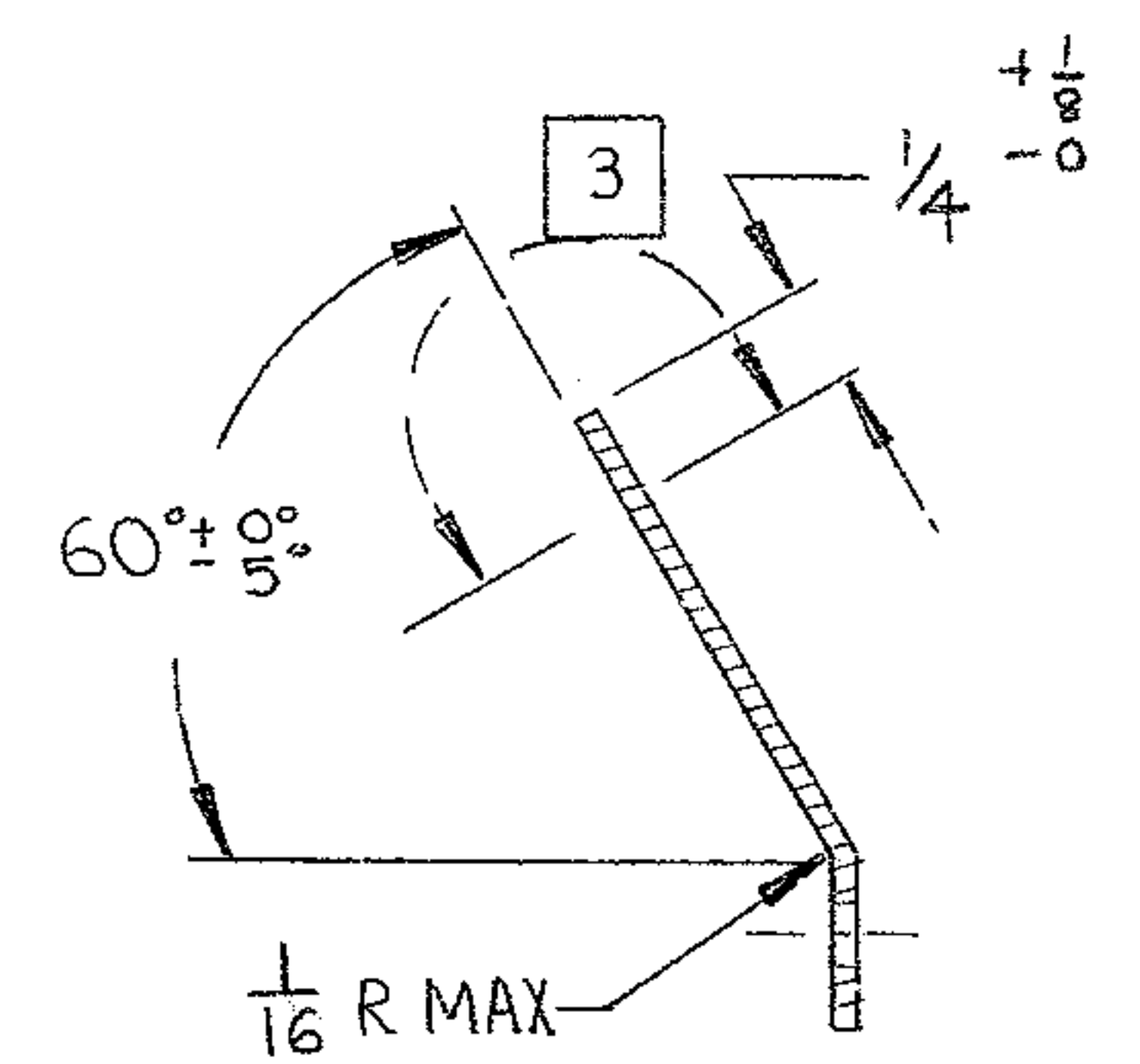
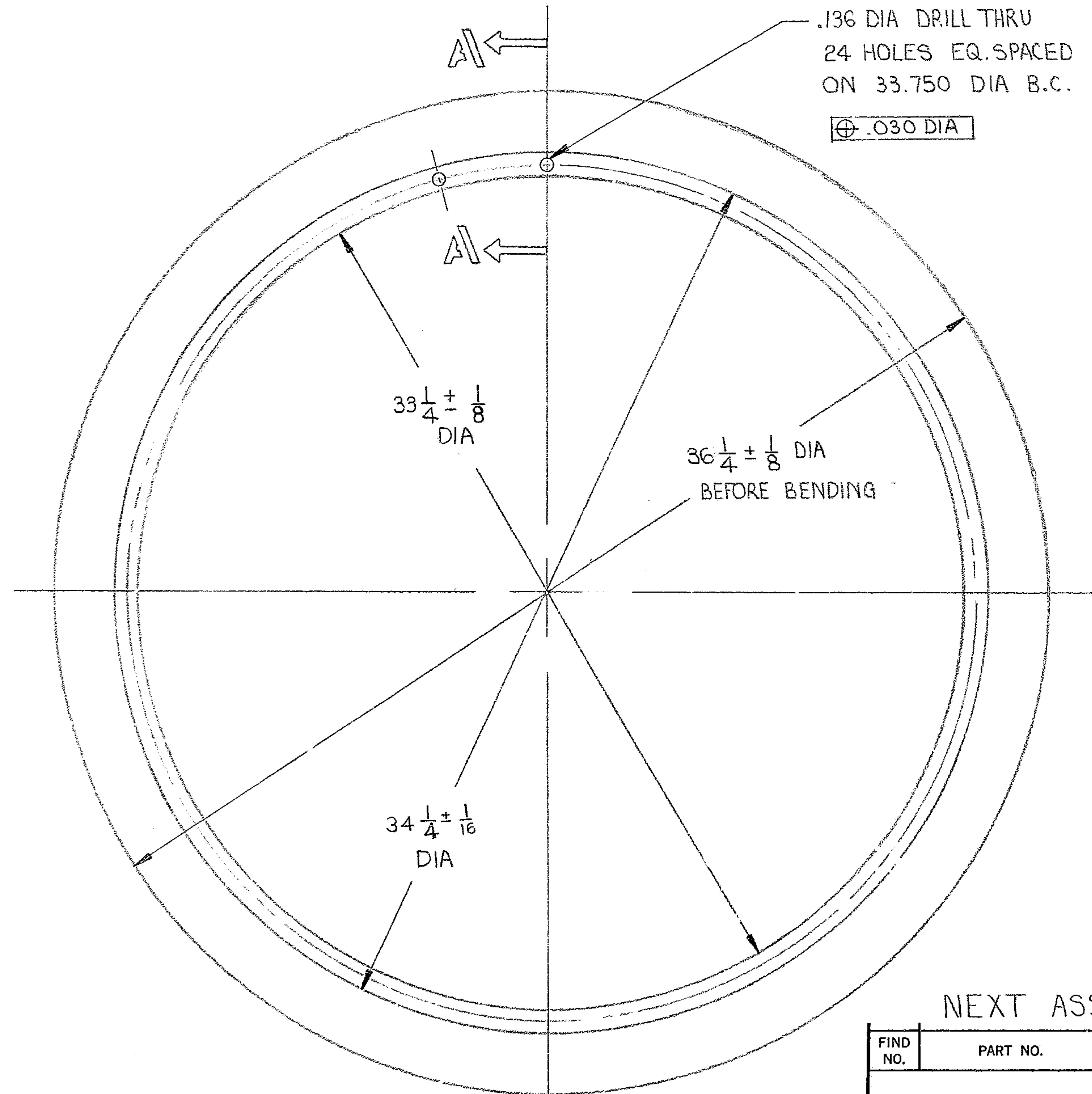

SECTION A-A

SCALE: NONE

NOTES:

1. ALL DIMENSIONS ARE IN INCHES
2. RUBBER STAMP PART NO. "2150.283C112" APPROX WHERE SHOWN
3. APPLY TEFLON TO SURFACE INDICATED. .005 MIN THICK. OPTION: APPLY TEFLON ALL OVER.

NEXT ASSY: 2150.283 E 102 (W.G.N 102987)

REF. FILE 1176

WESTERN GEAR CORPORATION
CONSTRUCTION PROJECTS
DEPARTMENT
APPROVED FOR
PROCUREMENT
P. Zupke DATE 1.6.69

FIND NO.	PART NO.	DESCRIPTION	QTY	MATERIAL	CODE IDENT
LIST OF MATERIAL (LM)					
LIMITS ON MACHINED DIMENSIONS EXCEPT AS NOTED ANGULAR = ± 1° 0'		150 IN STELLAR TELESCOPE MOUNTING		HEAVY MACHINERY DIVISION EVERETT, WASHINGTON SEAL, UPPER - COUDÉ 3 ASSY	
LINEAR: X = ± .1 .XXX = ± .010 .XX = ± .03 FRACTIONAL = ± 1/32		DRAWN S. SHAH 1-3-69 CHECK P. Zupke 1-6-69			
BREAK ALL SHARP EDGES		ENGR			
MATERIAL BRASS ASTM B 152 30 GAGE (.010) 36 1/4 O.D. X 33 1/4 I.D.		W.G.D 107 669 APPROVED		SIZE C	CODE IDENT NO. 16603
				2150.283 C112	REV A
SCALE		WT		LB	SHEET 1 OF 1