

4

3

2

1

REVISIONS				
ZONE	LTR	DESCRIPTION	DATE	APPROVED
C3	A	14 3/4 DIM WAS 14 3/8	11-6-68	
B4	A	63 FINISH DELETED	11-6-68	
A2	A	MATL : 15 DIM WAS 14 3/4	"	
	A	REVISED PER AURA APPD PRINT	"	

1/16 X 45° 2 PLACES

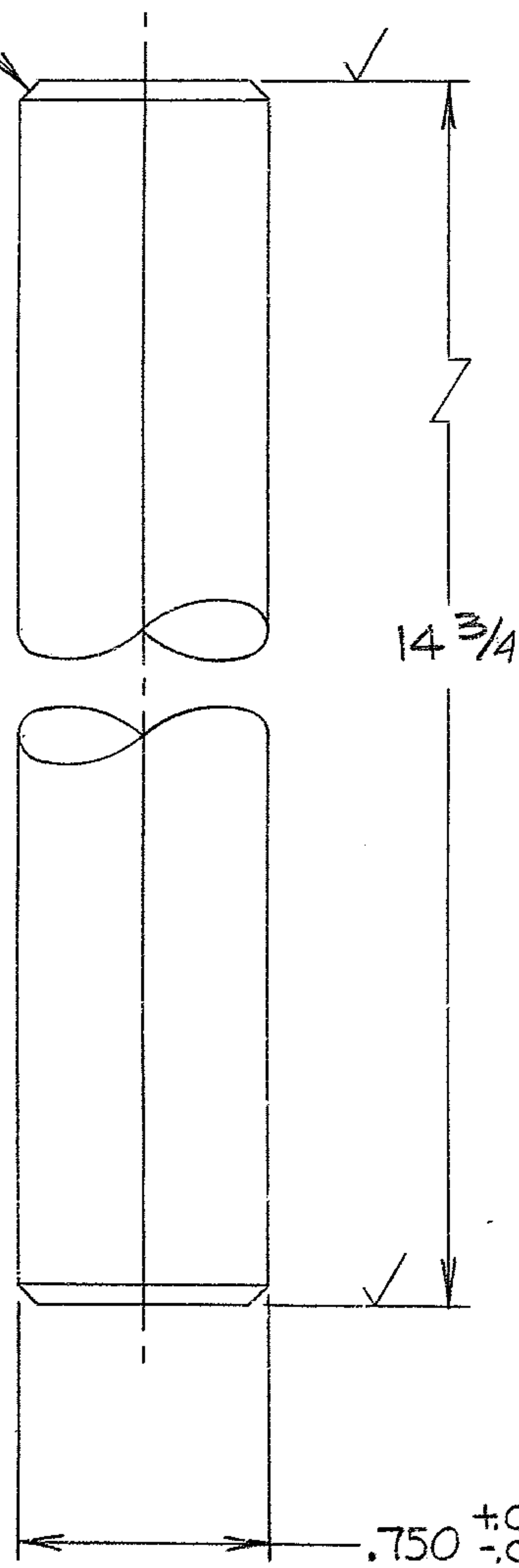

NOTES:

1. ALL DIMENSIONS ARE IN INCHES
2. ALL SURFACES MARKED ✓ TO BE ²⁵⁰ ✓ EXCEPT AS NOTED

REF. FILE 1176

NEXT ASSY 2150.283E002 (W.G.N 102,989)

FIND NO.	PART NO.	DESCRIPTION	QTY	MATERIAL	CODE IDENT
LIST OF MATERIAL (LM)					
LIMITS ON MACHINED DIMENSIONS EXCEPT AS NOTED ANGULAR = ± 1° 0' LINEAR: .X = ± .1 .XXX = ± .010 .XX = ± .03 FRACTIONAL = ± 1/32		150 IN STELLAR TELESCOPE MOUNTING		WESTERN GEAR CORPORATION HEAVY MACHINERY DIVISION EVERETT, WASHINGTON	
DRAWN BIRKENDAHL 3/13/68 CHECK <i>J. M. [Signature]</i> 5-18-68 ENGR		SHAFT, FOLLOWER, CELL COVER, COUDE #3 ASSY			
MATERIAL STL ROD .750 ^{+.000} / _{-.001} 15 LG AISI C1045 PRECISION SHAFTING		W.G.D. 107,446		SIZE C 16603	CODE IDENT NO. 2150.283C005
APPROVED				REV A	
SCALE 2/1		WT		LB	SHEET OF

TAG WITH PART NO. 2150.283C005

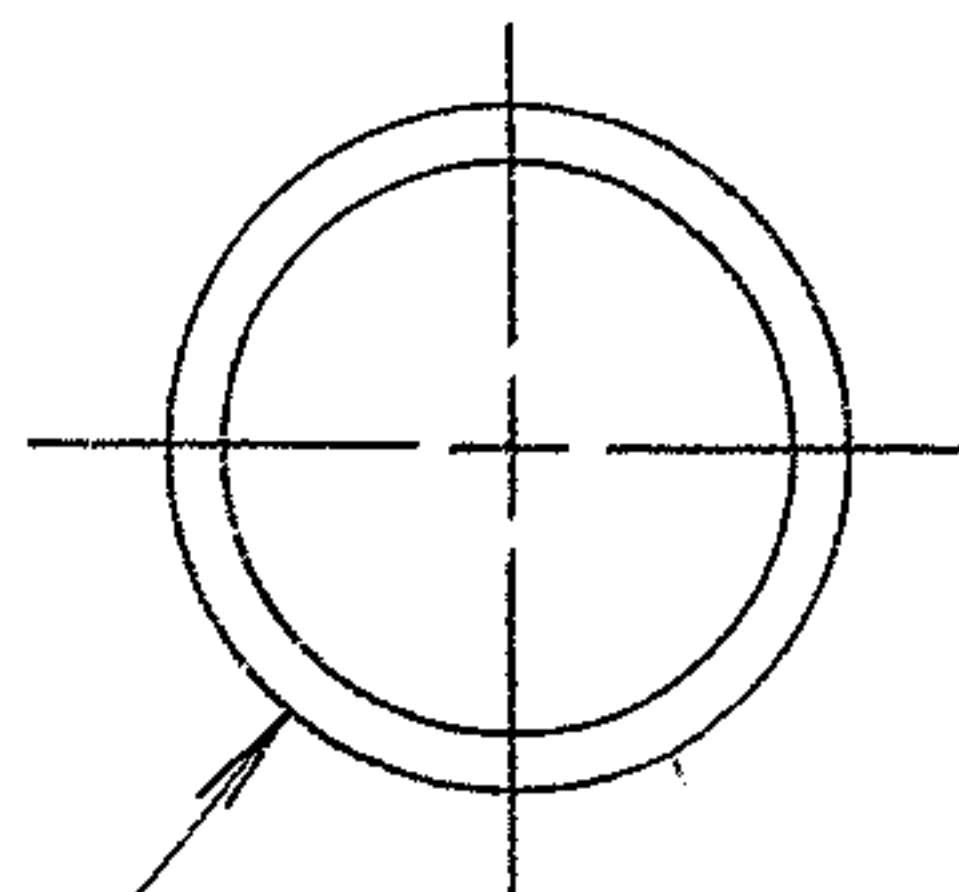

WESTERN GEAR CORPORATION
CONSTRUCTION PROJECTS
DEPARTMENT
APPROVED FOR
PROCUREMENT

PG DATE 11/21/68