

5

4

3

2

1

REVISIONS				
ZONE	LTR	DESCRIPTION	DATE	APPROVED
	A	REVISED PER AURA APP PRINT	11-6-68	

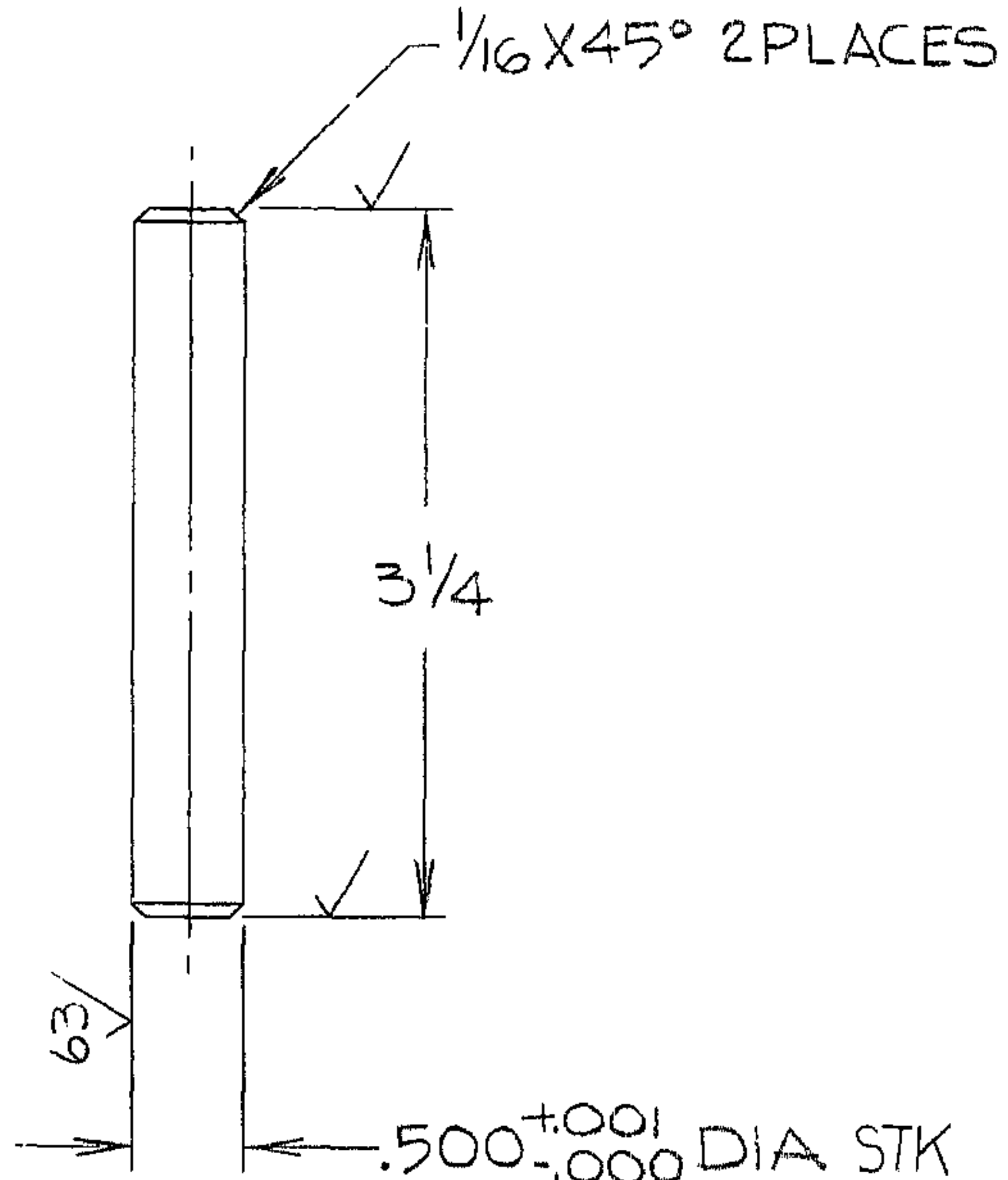

- NOTES:
1. ALL DIMENSIONS ARE IN INCHES
 2. ALL SURFACES MARKED ✓ TO BE ²⁵⁰✓ EXCEPT AS NOTED
 3. MATERIAL: STL AISI C1045 PRECISION SHAFTING 1/2 DIA X 3 1/4 LG.

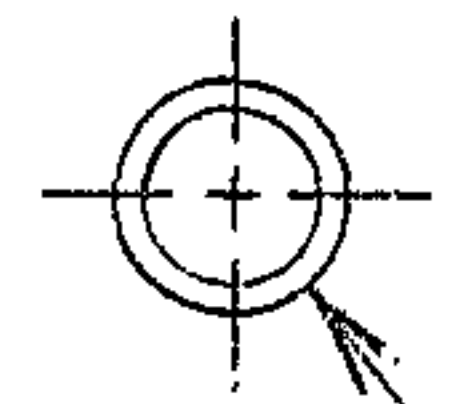

TAG WITH PART NO.
2150.283 B607

WESTERN GEAR CORPORATION
CONSTRUCTION PROJECTS
DEPARTMENT
APPROVED FOR
PROCUREMENT
DATE 11/2/68

REF. 1176

NEXT ASSY 2150.283 E602 (W.G.N 102,988)

LIMITS ON MACHINED DIMENSIONS EXCEPT AS NOTED ANGULAR ± 1° 0' LINEAR .X = ± .1 .XX = ± .03 .XXX = ± .010 FRACTIONAL ± 1/32 BREAK ALL SHARP EDGES	150IN STELLAR TELESCOPE MOUNTING		WESTERN GEAR CORPORATION HEAVY MACHINERY DIVISION EVERETT, WASHINGTON		
	DRAWN BIRKENDAHL 3/13/68 CHECK <i>[Signature]</i> 5-18-68 ENGR		SHAFT, CAM PIVOT COUDE #3 ASSY		
W.G.C 112,456		SIZE B	CODE IDENT NO. 16603	2150.283B607	REV A
APPROVED		SCALE 1/1	WT.	LB	SHEET 1 OF 1