

5

4

3

2

1

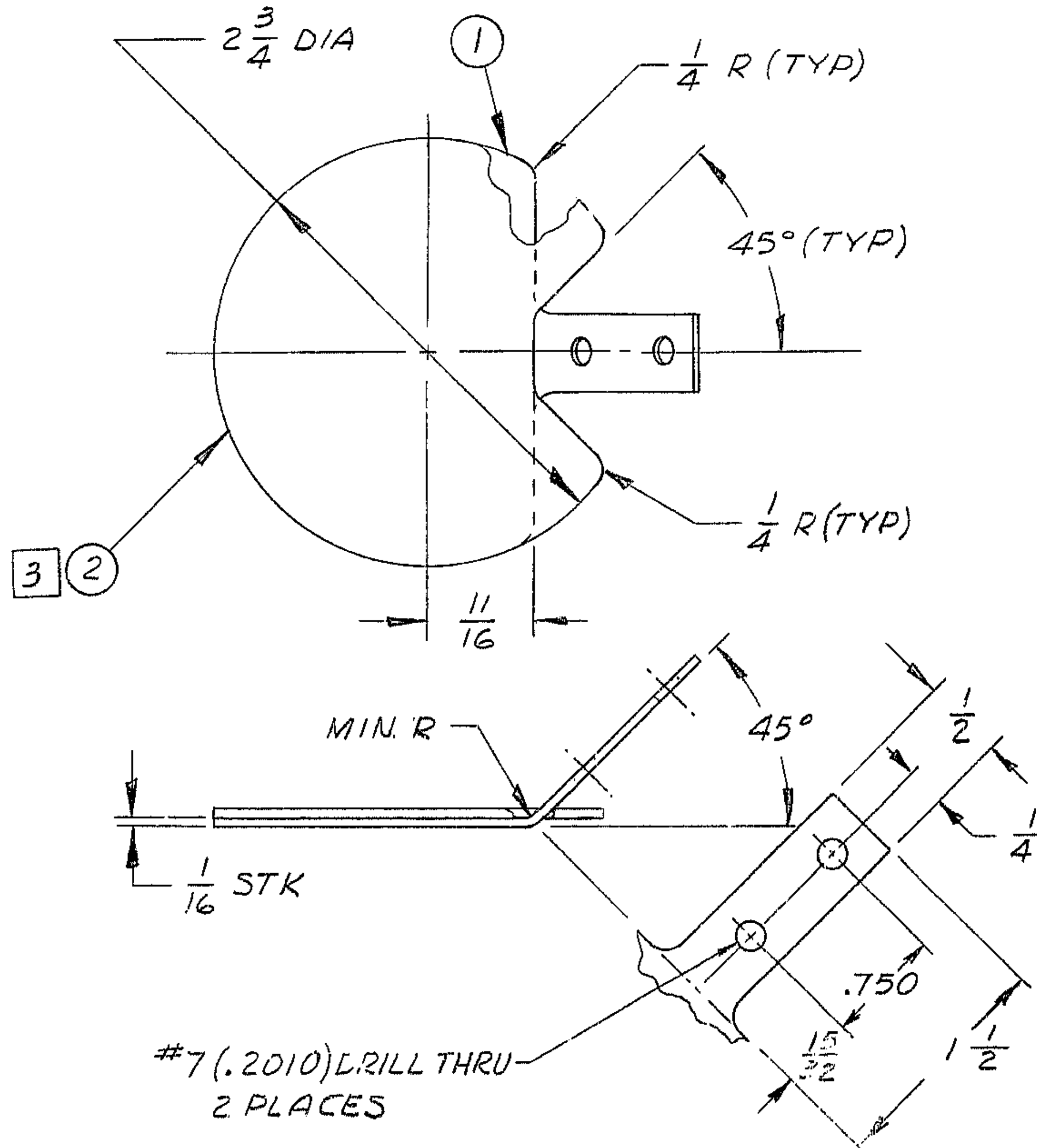

REVISIONS				
ZONE	LTR	DESCRIPTION	DATE	APPROVED
B2	A	NOTE NO. 4 ADDED	11-2-68	
C1	A	PC. NO 2 ; 40-45 DUROMETER ADDED	"	
	A	REVISED PER AURA APPD PRINT	"	

MATERIAL LIST				
PC No	QTY	DESCRIPTION	MATL & SPEC	ROUGH WT
1	1	2 3/4 x 1/16 THK	AL ALY 6061-T651	
2	1	2 3/4 x 1/16 THK	NEOPRENE 40-45 DUROMETER	

NOTES

1. ALL DIMENSIONS ARE IN INCHES
2. TAG PART WITH PART No. 2150.283B 513.
3. BOND ITEM (2) TO ITEM (1)
4. FLAT BLACK ANODIZE PC. NO. 1 BEFORE BONDING

REF. FILE 1176

NEXT ASSY 2150.283E 502 (WGN 102974)

LIMITS ON MACHINED DIMENSIONS EXCEPT AS NOTED ANGULAR ± 1° 0' LINEAR .X = ± .1 .XX = ± .03 .XXX = ± .010 FRACTIONAL ± 1/32 BREAK ALL SHARP EDGES	150 IN STELLAR TELESCOPE MOUNTING		Western GEAR CORPORATION HEAVY MACHINERY DIVISION EVERETT, WASHINGTON	
	DRAWN G COSTA		CAP CENTRAL DUST COVER, COUDE No 3	
	CHECK <i>V. Nicolaj</i>			
	ENGR		SIZE B APPROVED	CODE IDENT NO. 16603 2150.283B513
WGC 112453		SCALE 1/1	WT.	LB SHEET 1 OF 1