

REVISIONS

LTR	DESCRIPTION	DATE	APPROVED
A	RELEASED FOR CONSTRUCTION	11-14-68	
A	WGB114009 WAS WGC114009		
B	2150.283A014 WAS 2150.283A011	1-15-69	

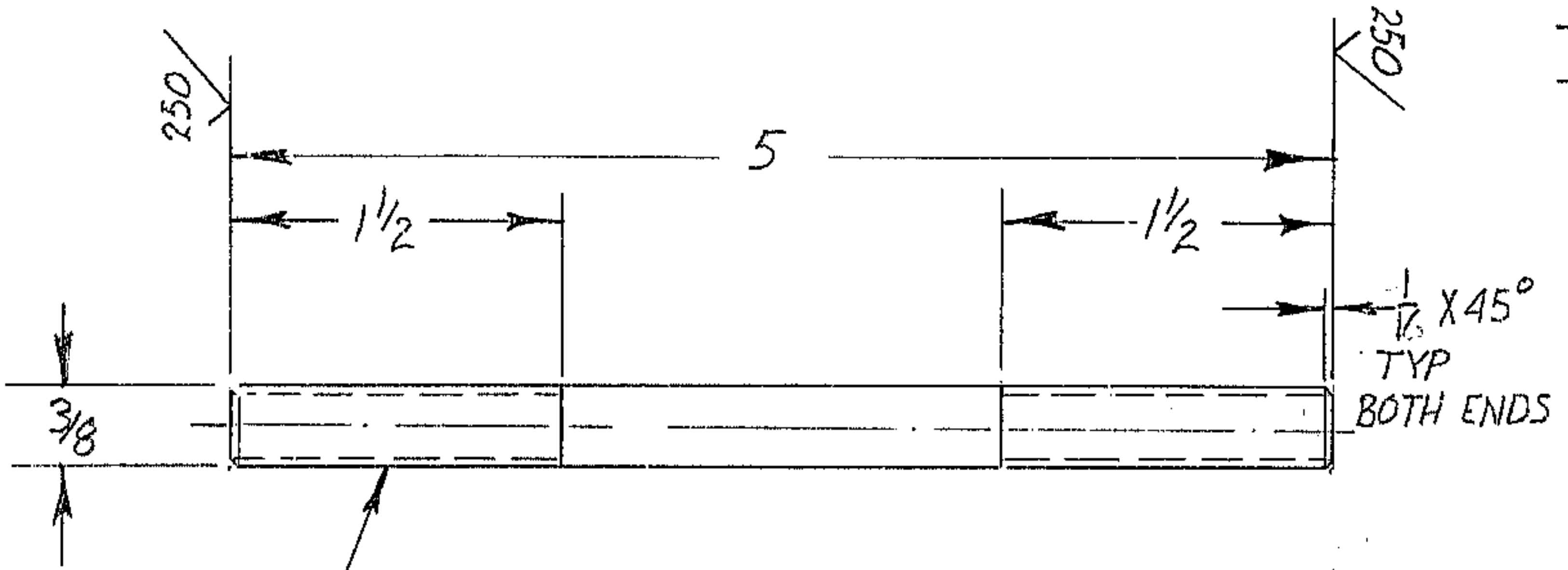

3/8-16 UNC 2A  
BOTH ENDS

REF. FILE: 1176

NOTES

WESTERN GEAR CORPORATION  
CONSTRUCTION PROJECTS  
DEPARTMENT

1. ALL DIMENSIONS ARE IN INCHES
2. TAG WITH PART NO. 2150.283A014
3. MATL: STL AISI C1018 CF, 3/8 DIA X 5 LG
4. CAD. PLATE

APPROVED FOR  
(WGB1102989)  
PROCUREMENT

NEXT ASSY 2150.283E002 11/21/68

LIMITS ON MACHINED DIMENSIONS EXCEPT AS NOTED

ANGULAR ± 1° 0'  
LINEAR  
.X = ± .1  
.XX = ± .03  
.XXX = ± .010  
FRACTIONAL ± 1/32

BREAK ALL SHARP EDGES

150 IN. STELLAR TELESCOPE MOUNTING

DRAWN D THOMPSON

CHECK

ENGR

WGB.114009

APPROVED

WESTERN GEAR CORPORATION

HEAVY MACHINERY DIVISION  
EVERETT, WASHINGTON

STUD, COVER CELL, COUDE #3

SIZE

A

CODE IDENT NO.

16603

2150.283A014

REV

B

SCALE 1/1

WT.

LB

SHEET /

OF /

W 114009