

4

3

2

1

REVISIONS				
ZONE	LTR	DESCRIPTION	DATE	APPROVED
	A	REVISED PER AURA APP PRINT	10/22/61	
	B	MODIFIED FOR PART NO. 42	4-17-70	S.
C-4	C	DELETED .501/.498 DIA SHAFT END ADDED P.2	8-11-71	LDS

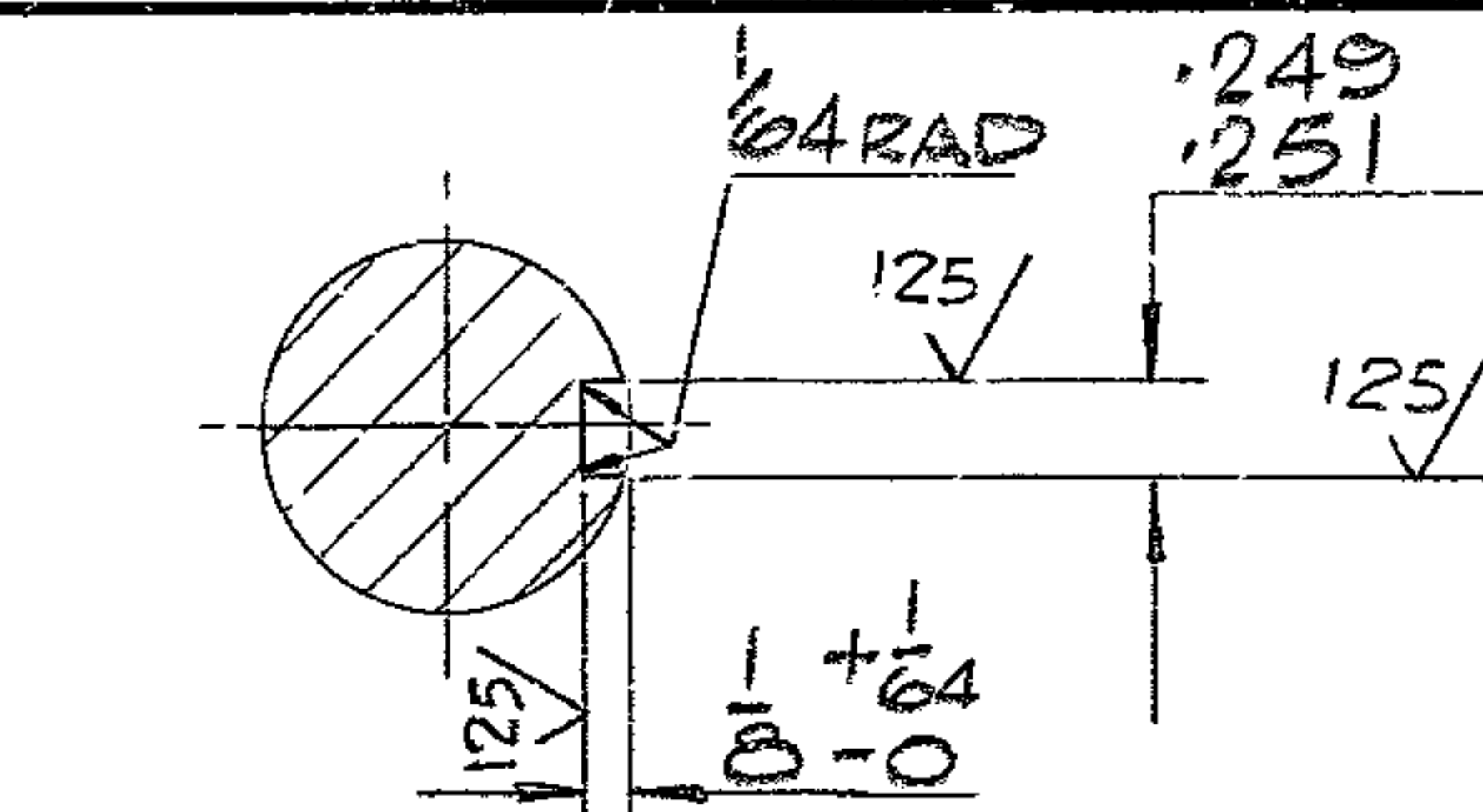

SECTION A-A  
SCALE: 1"=1IN.

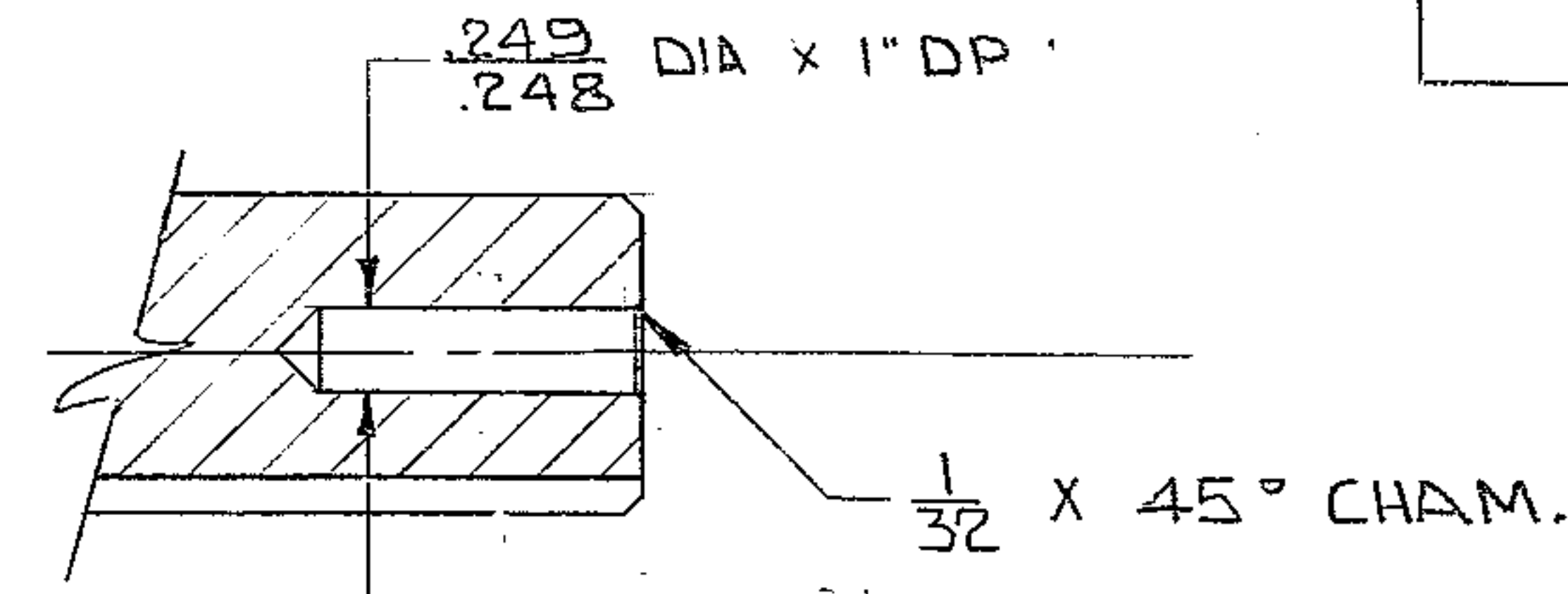

SECTION D-D  
P.2 NOT SHOWN

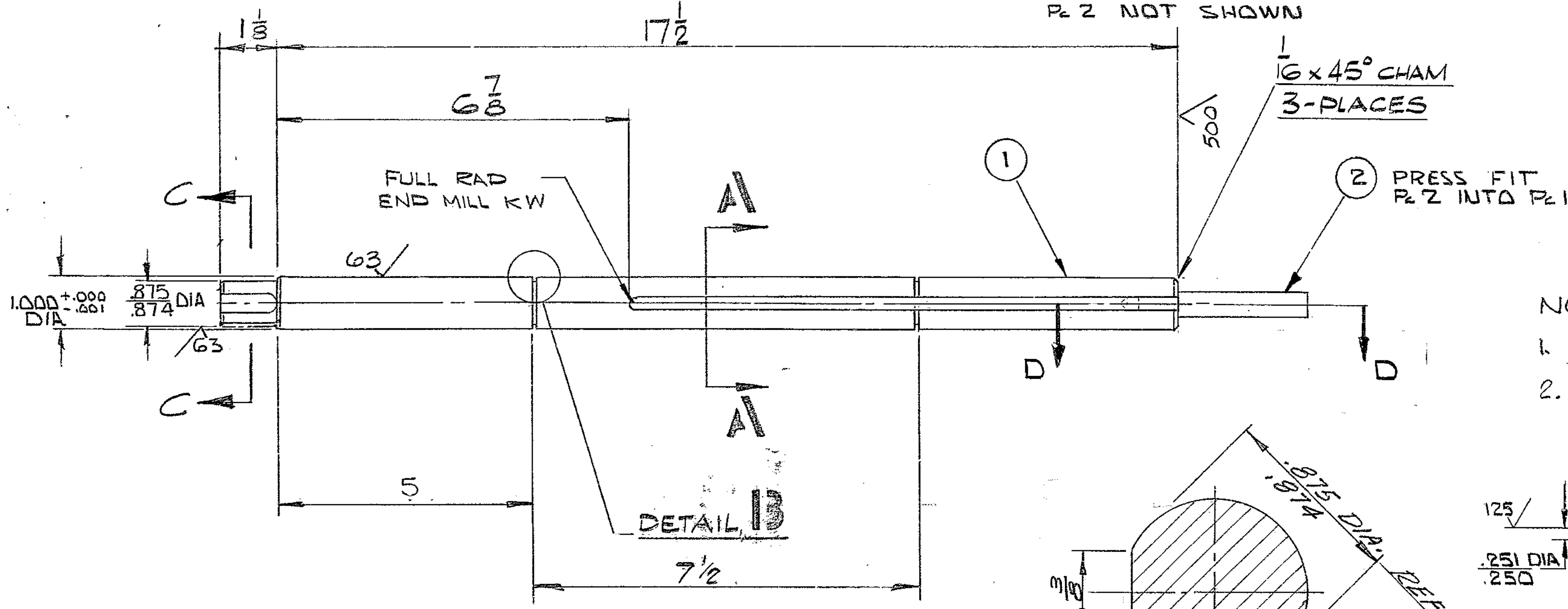

NOTES  
1. ALL DIMENSIONS IN INCHES  
2. TAG WITH PART NO 2150.281C034

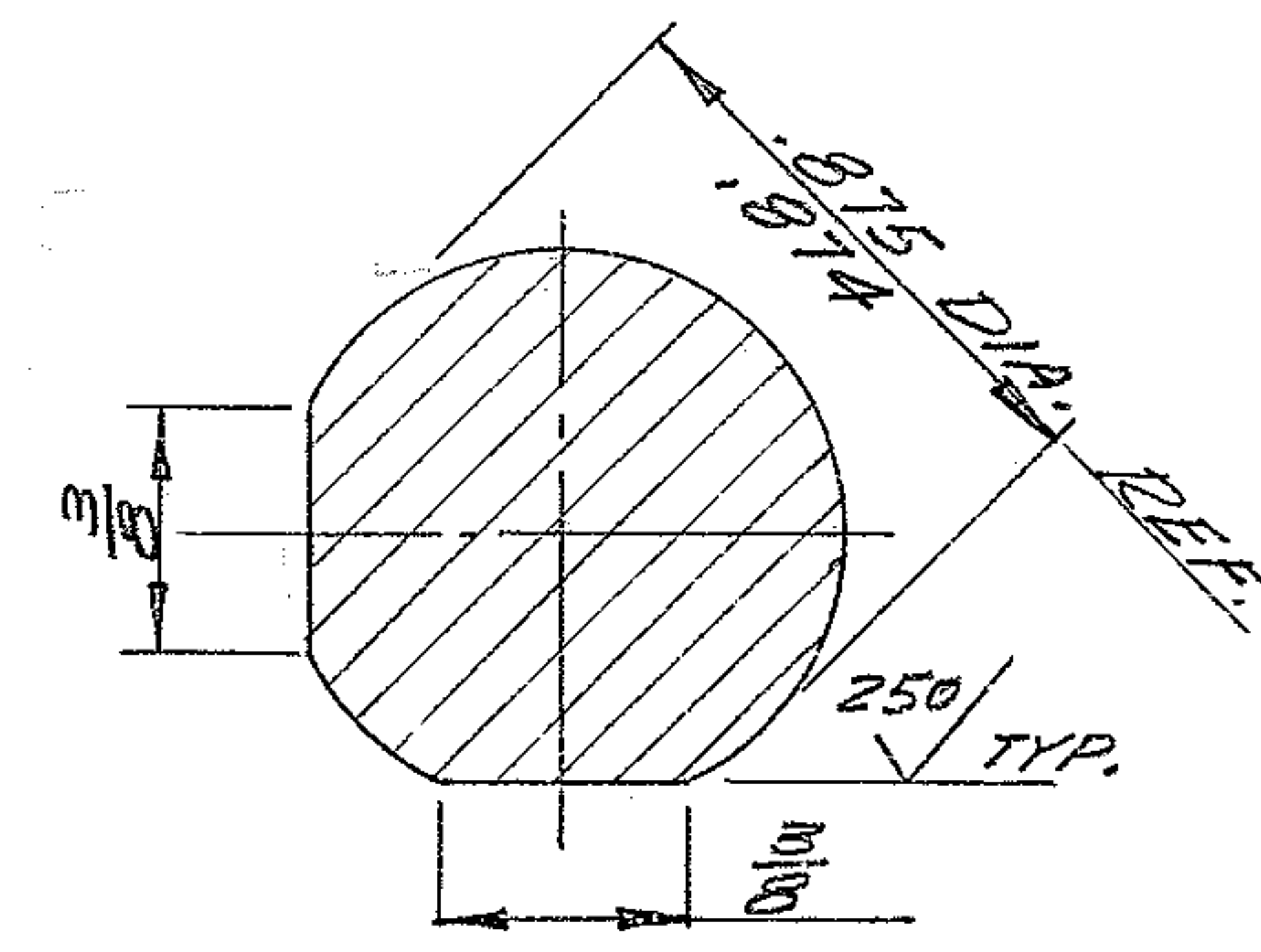

C-C  
SCALE 2/1

P.2  
DETAIL

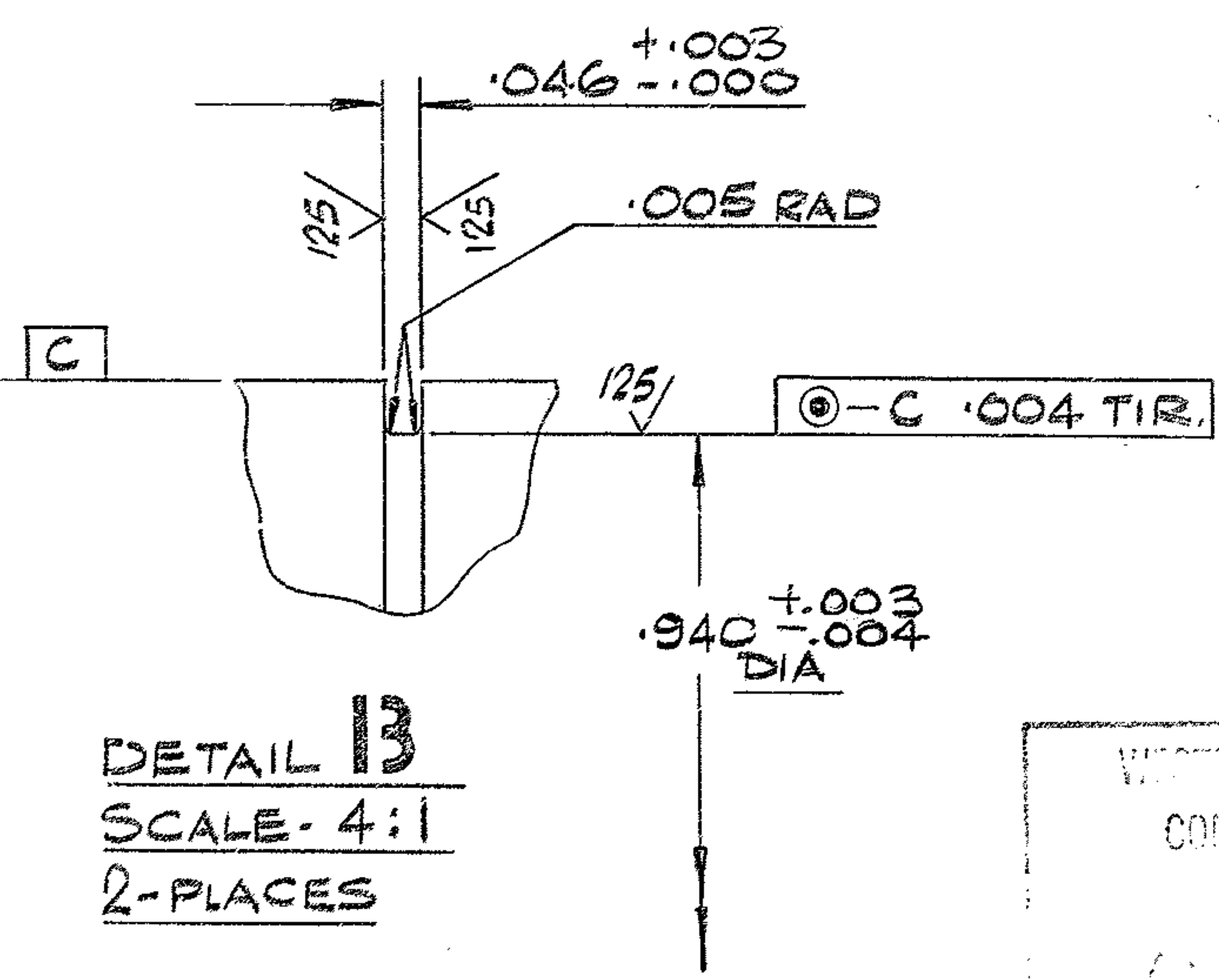

DETAIL B  
SCALE: 4:1  
2-PLACES

REF. FILE 1175

NEXT ASSY 2150.281E002 WGN 103002

FIND NO.	PART NO.	DESCRIPTION	QTY	MATERIAL	CODE IDENT
2		1/2 DIA x 3/4 LG	1	STL AISI 1018 OR 4140	
1		1.000 ±.000/.001 DIA x 17 5/8	1	STL PREC. SHAFT AISI 1045	

LIST OF MATERIAL (LM)

LIMITS ON MACHINED DIMENSIONS EXCEPT AS NOTED ANGULAR = ± 1° 0' LINEAR: X = ± .1    .XXX = ± .010 .XX = ± .03    FRACTIONAL = ± 1/32 BREAK ALL SHARP EDGES	150 IN STELLAR TELESCOPE MOUNTING	<b>Western</b> GEAR CORPORATION HEAVY MACHINERY DIVISION EVERETT, WASHINGTON
	DRAWN MAUNDERS 5/30/68 CHECK <i>Sw.H.</i> 8-15-68 ENGR	
MATERIAL SEE L/M	WGD 107550 APPROVED	SIZE CODE IDENT NO. REV <b>C 16603</b> 2150.281.C034 C
SCALE 1/2" = 1" WT		4 LB SHEET 1 OF 1

WESTERN MACHINERY DIVISION  
CONTRACT NO. 1175  
FOR PROCUREMENT  
DATE 11/21/68