

4

3

2

1

REVISIONS				
ZONE	LTR	DESCRIPTION	DATE	APPROVED
	A	REVISED PER. AURA APP PRINT	10-22-68	

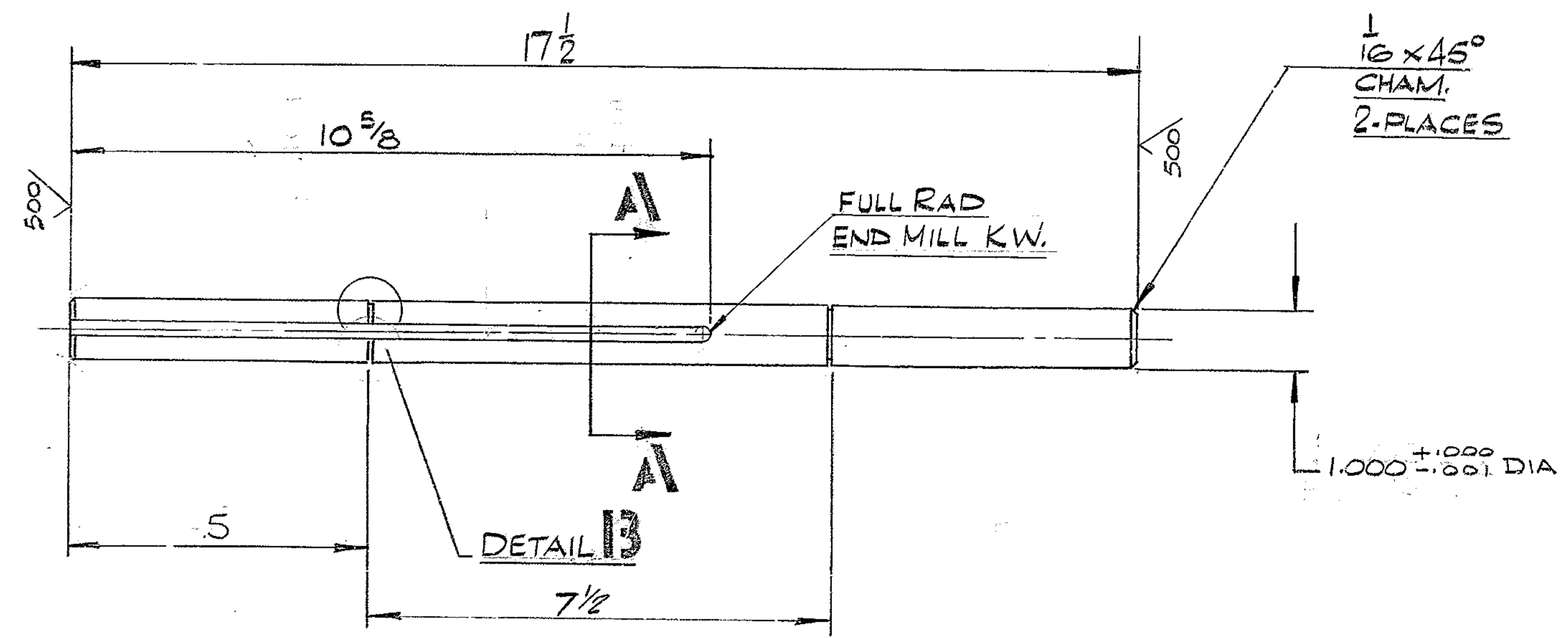
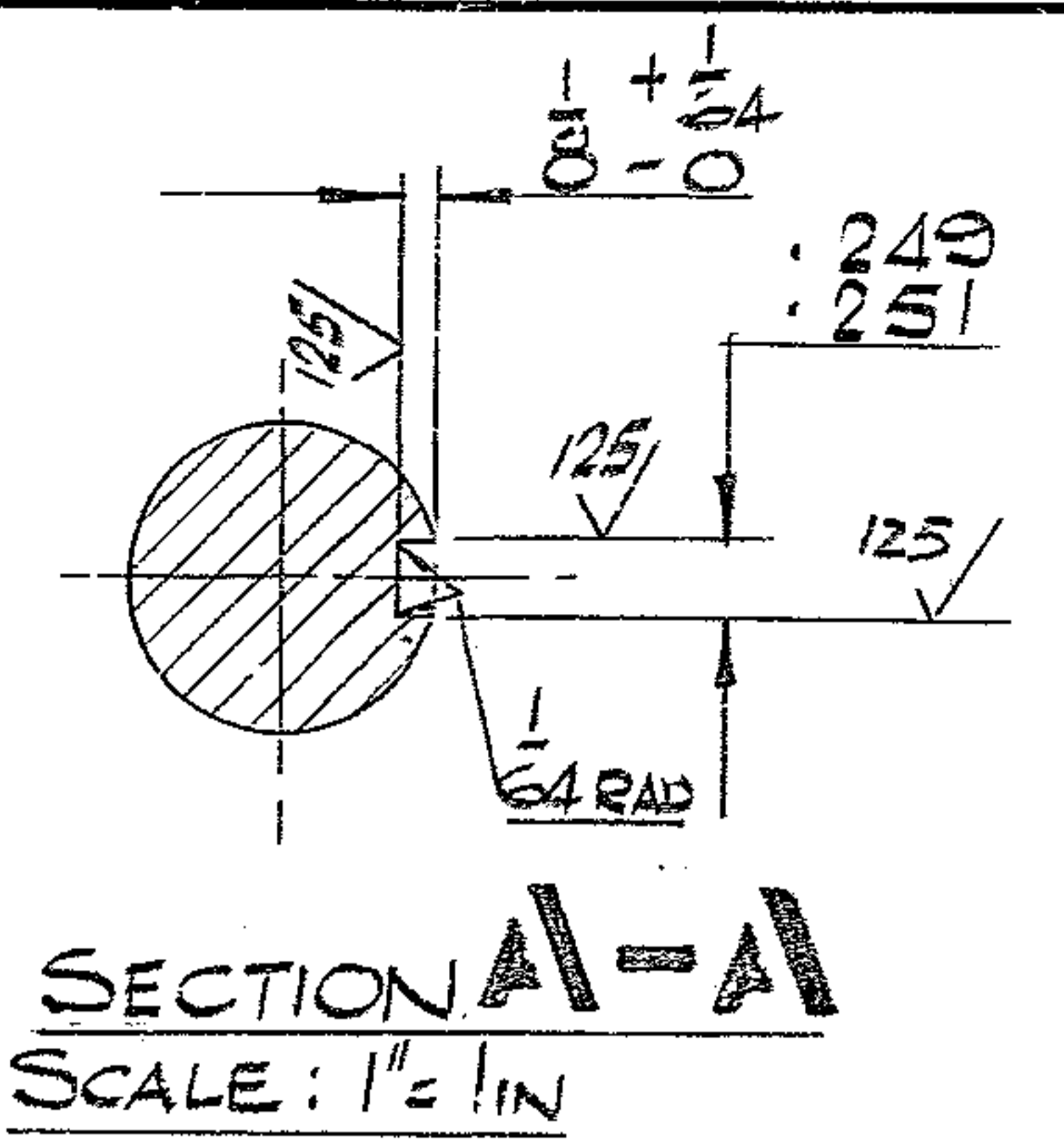

NOTES:
1. ALL DIMENSIONS IN INCHES
2. TAG WITH PART NO 2150.281.C033

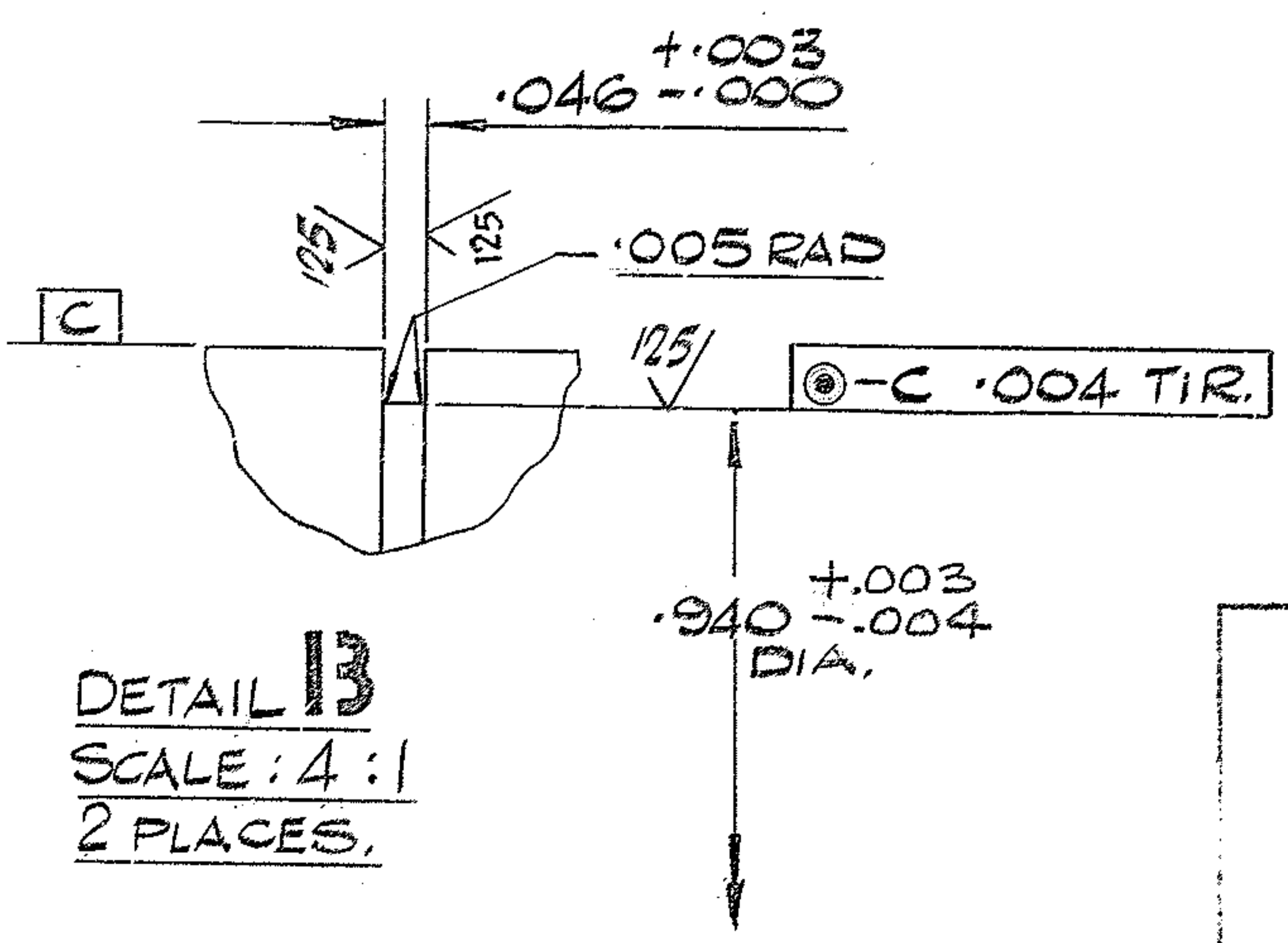

NEXT ASSY, 2150.281.E002

WGN 103002

REF. 1175

WESTERN GEAR CORPORATION
CONSULTANT PROJECTS
APPROVED FOR
PROCUREMENT
PG. DATE 11/21/68

FIND NO.	PART NO.	DESCRIPTION	QTY	MATERIAL	CODE IDENT
LIST OF MATERIAL (LM)					
LIMITS ON MACHINED DIMENSIONS EXCEPT AS NOTED ANGULAR = ± 1° 0'		150 IN STELLAR TELESCOPE MOUNTING		WESTERN GEAR CORPORATION HEAVY MACHINERY DIVISION EVERETT, WASHINGTON	
LINEAR: X = ± .1 .XXX = ± .010 .XX = ± .03 FRACTIONAL = ± 1/32		DRAWN MAUNDERS 5/30/68 CHECK <i>W.K.</i> 8-15-68 ENGR			
BREAK ALL SHARP EDGES		MATERIAL		DUST COVER & IRIS ASSY, PRIMARY MIRROR	
STEEL. PREC. SHAFT.		WGD 107.590		SIZE CODE IDENT NO. REV	
1.000 +.000 / -.001 DIA STK.		APPROVED		C 16603 2150.281.C033 A	
				SCALE 1/2" = 1IN WT 4 LB SHEET 1 OF 1	