

4

3

2

1

REVISIONS				
ZONE	LTR	DESCRIPTION	DATE	APPROVED
	A	REVISED & RE-DWN. PER AURA PRINT	11-4-68	
	A	APP'D. FOR CONST. PER AURA 9-20-68	"	
C-2	B	ADDED 3/8 LOC. DIM	1-20-71	JW

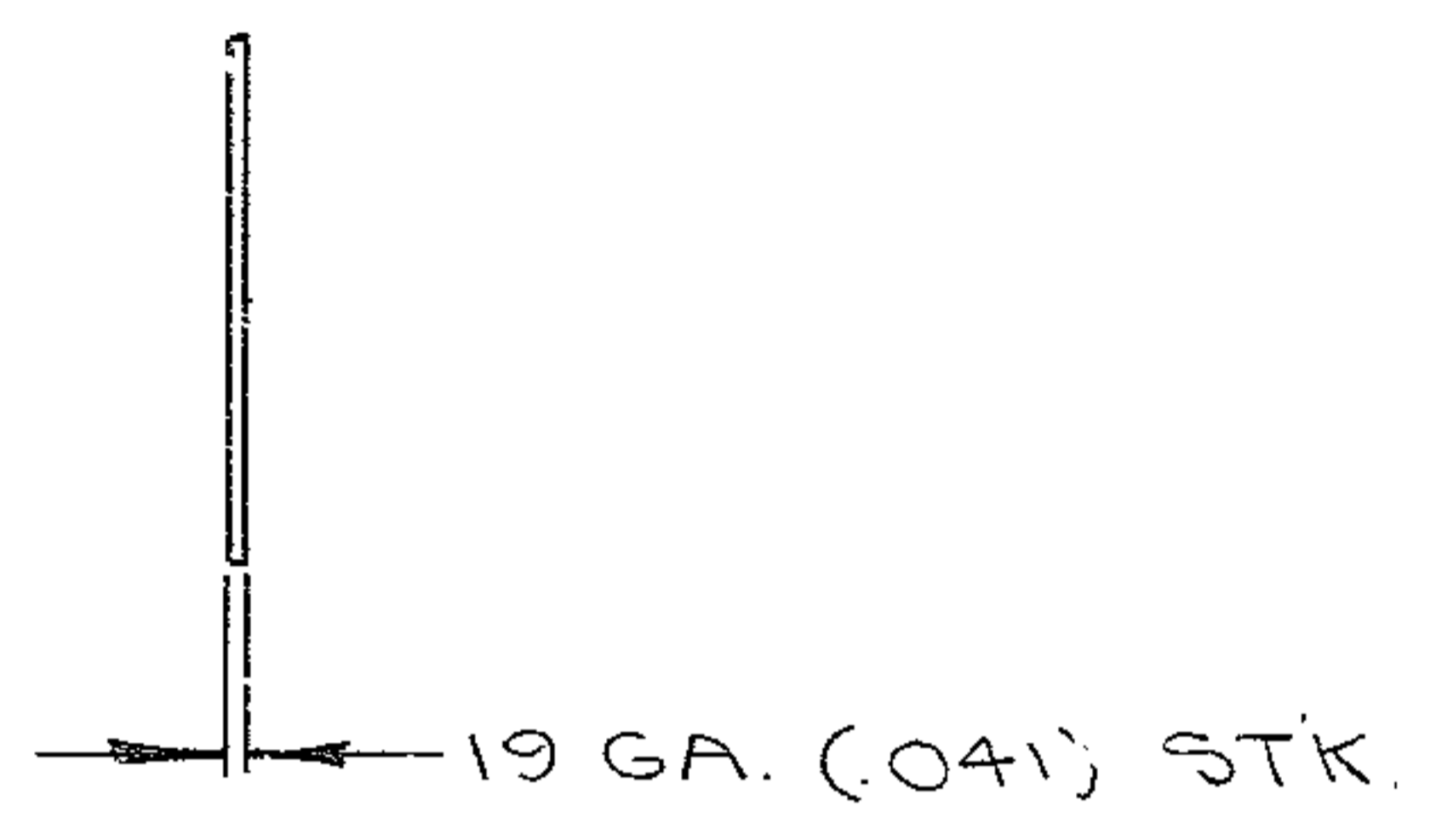
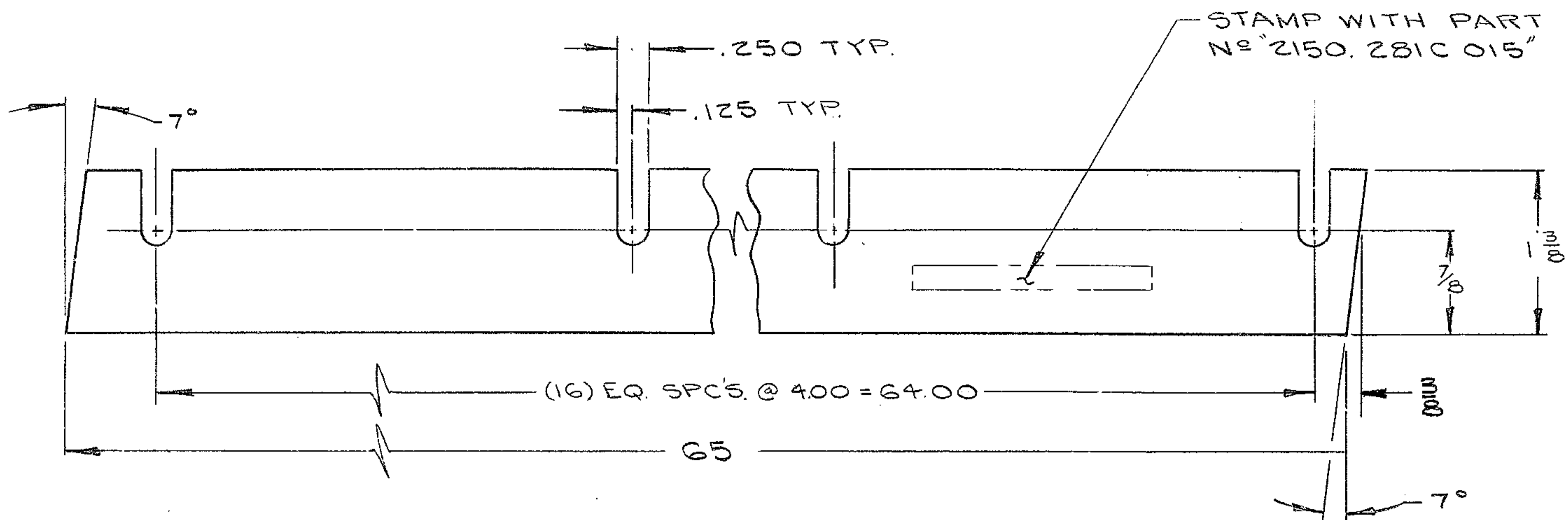

NOTES:

- 1. ALL DIMENSIONS ARE IN INCHES.
- 2. BREAK ALL SHARP EDGES.

NEXT ASS'Y.: 2150.281E 002 (W.G.N 103 022)

REF. FILE	1175
-----------	------

FIND NO.	PART NO.	DESCRIPTION	QTY	MATERIAL	CODE IDENT
LIST OF MATERIAL (LM)					
LIMITS ON MACHINED DIMENSIONS EXCEPT AS NOTED ANGULAR = ± 1° 0'		150 IN STELLAR TELESCOPE MTG.		Western GEAR CORPORATION HEAVY MACHINERY DIVISION EVERETT, WASHINGTON	
LINEAR: .X = ± .1 .XXX = ± .010 .XX = ± .03 FRACTIONAL = ± 1/32		DRAWN J. MILLER 11-4-68			
BREAK ALL SHARP EDGES		CHECK		SEAL STRIP ~ DUST COVER	
MATERIAL		ENGR			
302 STAINLESS STL		W.G.D 107593		SIZE	CODE IDENT NO.
APPROVED				C 16603	2150.281C 015
				SCALE FULL	WT
				LB	SHEET 1 OF 1
				REV	B