

REVISIONS				
ZONE	LTR	DESCRIPTION	DATE	APPROVED
	A	REVISED PER AURA APPD CONST. PRINT DATED 6 MAY 68	7 MAY 68	

17/32 DR. THRU
CBORE 1" DIA X DEPTH SHOWN
2 PLACES

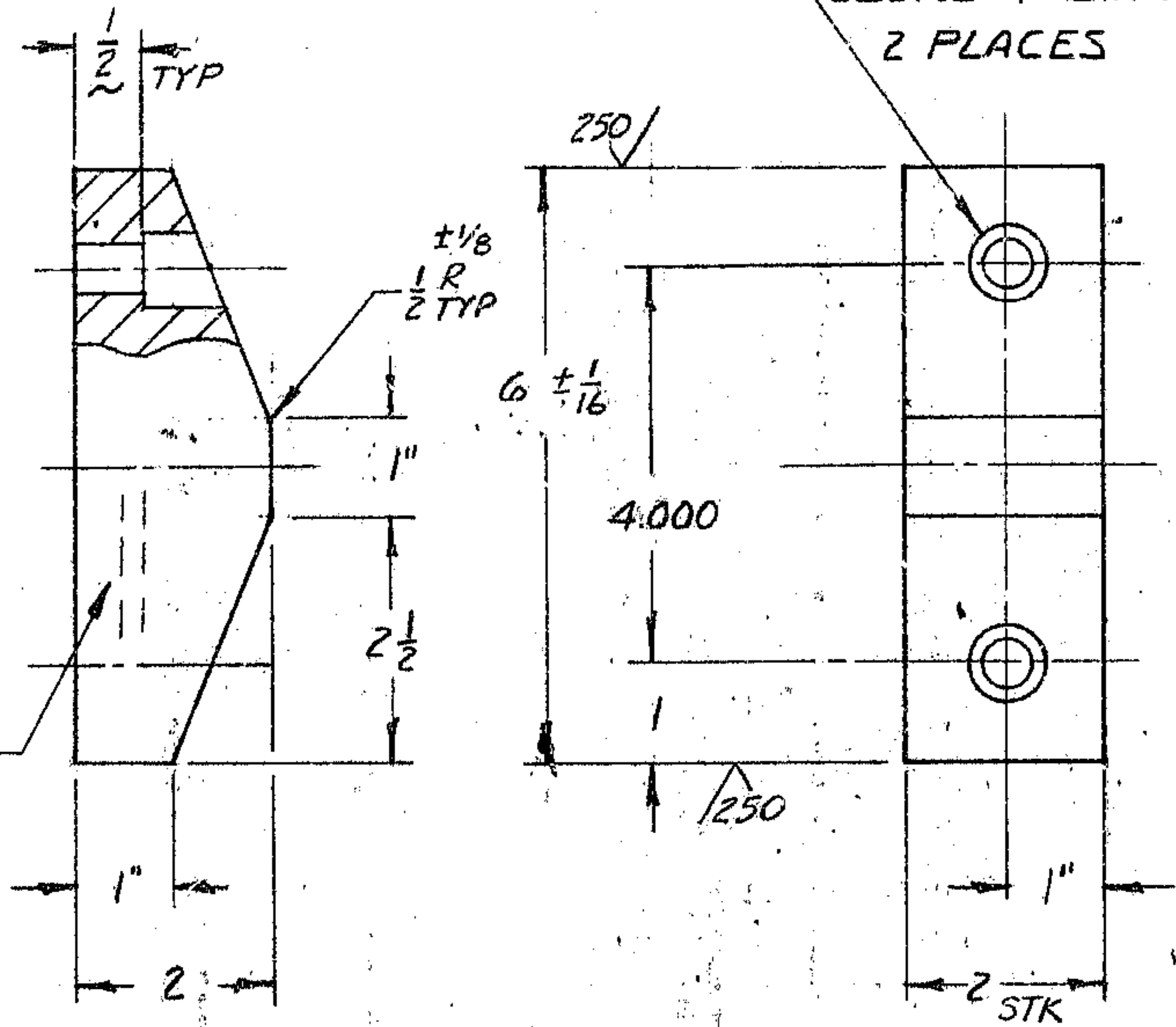

STAMP PART NO.
"2150.281B116"

- NOTES:
1. ALL DIMENSIONS ARE INCHES.
 2. FINISH 125 ALL OVER EXCEPT AS NOTED.
 3. MATERIAL: STL. AISI 61018 OR EQ.
BAR 2 1/4 x 2 x 6 1/4 LG.

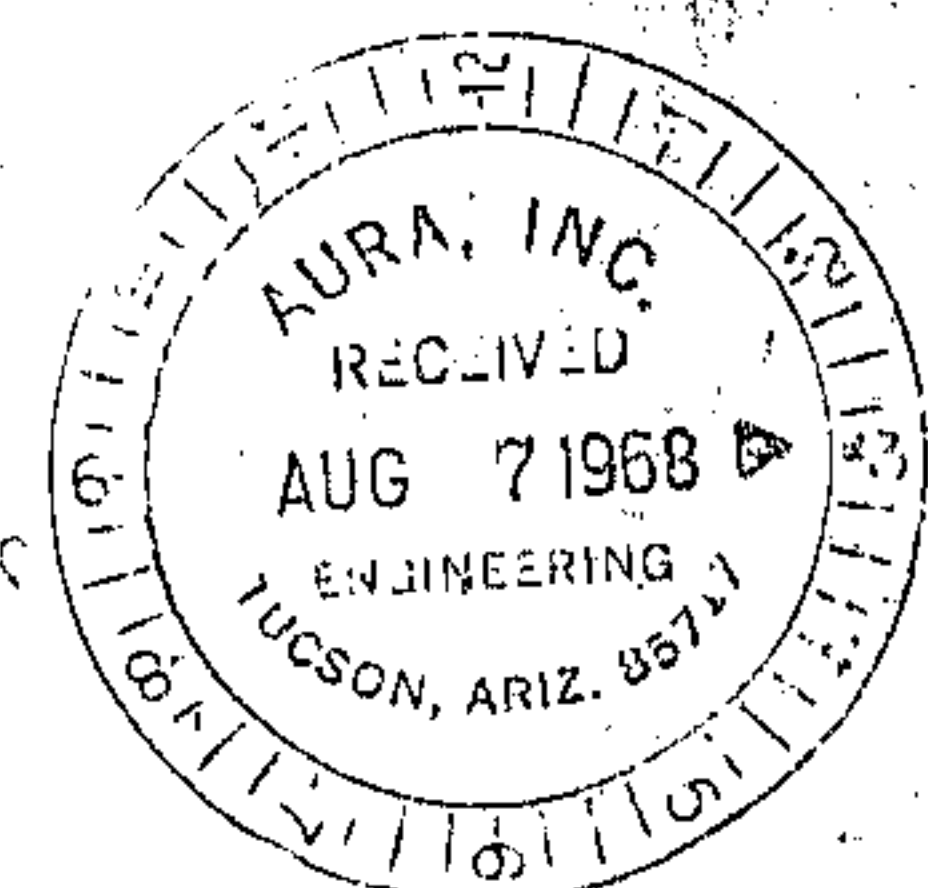

REF. FILE 1175

NEXT ASSY: 2150.281E102 (W.G. N102948)

WESTERN GEAR CORPORATION
CONSTRUCTION PROJECTS
DEPARTMENT
APPROVED FOR
PROCUREMENT

J.R. DATE 8 MAY 68

LIMITS ON
MACHINED DIMENSIONS
EXCEPT AS NOTED
ANGULAR ± 1° 0'
LINEAR
.X = ± .1
.XX = ± .03
.XXX = ± .010
FRACTIONAL ± 1/32

BREAK ALL
SHARP EDGES

150 IN. STELLAR
TELESCOPE MOUNTING
DRAWN T.E. HARPER 5-6-68
CHECK GENE RUSSO 6 MAY 68
ENGR
W.G. C11257B
APPROVED

Western GEAR CORPORATION HEAVY MACHINERY DIVISION
EVERETT, WASHINGTON
ACTUATOR, ZENITH L.S. -
CENTER SECTION & LOWER GIRDER
SIZE B CODE IDENT NO. 2150.281B116 REV A
SCALE 1/2 WT. 5 1/2 LB SHEET 1 OF 1