

THIS DOCUMENT CONTAINS INFORMATION PROPRIETARY TO WESTERN GEAR CORPORATION. ALL DESIGN, MANUFACTURING, REPRODUCTION, USE, PATENT, AND SALES RIGHTS REGARDING THE SAME ARE HEREBY EXPRESSLY RESERVED BY WESTERN GEAR CORPORATION. THIS DOCUMENT IS SUBMITTED FOR REFERENCE PURPOSES ONLY AND SHALL NOT BE DISCLOSED TO ANY UNAUTHORIZED PERSON OR INCORPORATED INTO ANY OTHER PROJECT.

REVISIONS				
ZONE	LTR	DESCRIPTION	DATE	APPROVED

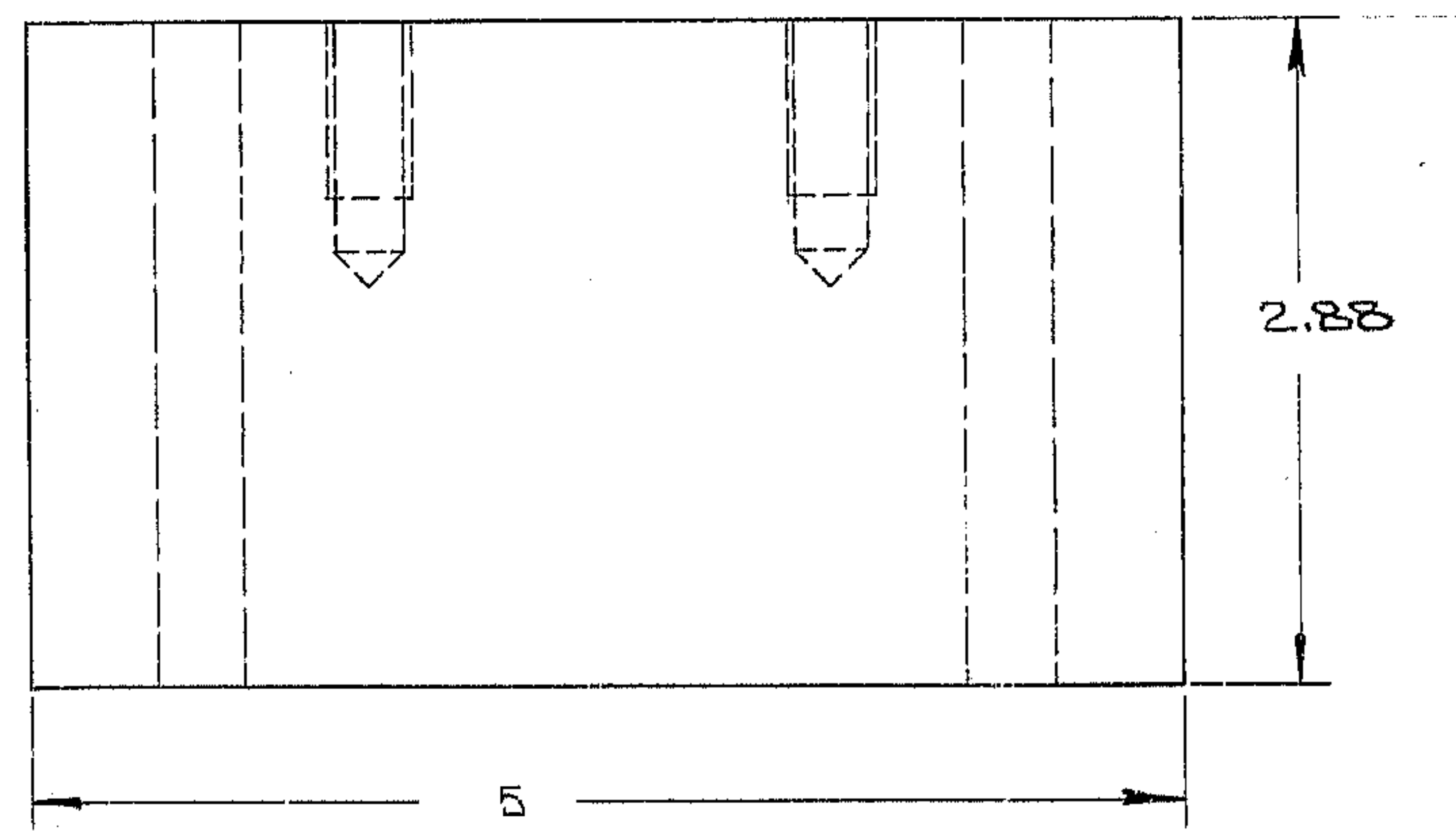
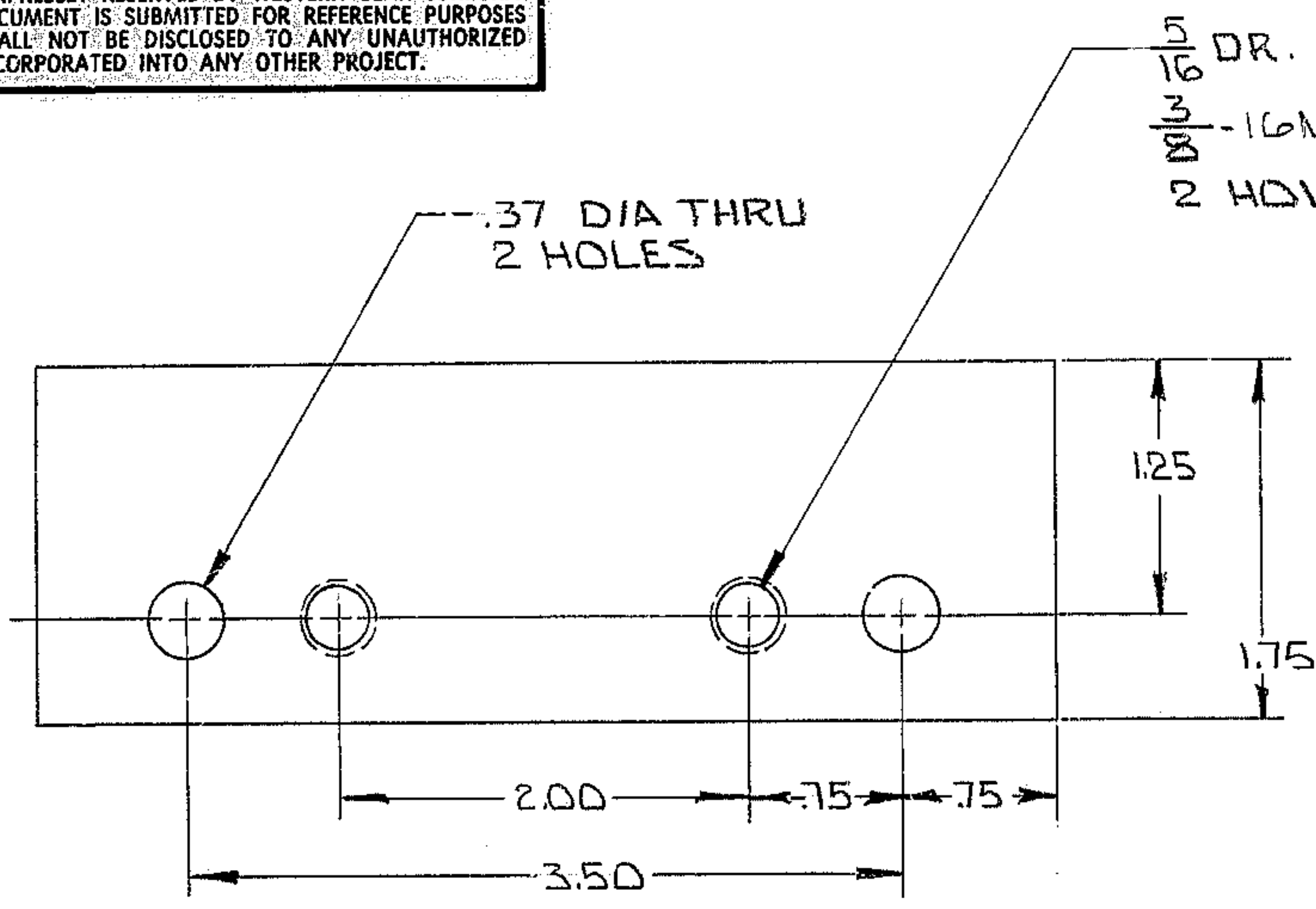

NOTE  
 1. MAT'L STL ASTM A-36 1 3/4 X 3 X 5  
 2. STL STAMP P/N 2150.281 B095

REF. FILE 1175

LIMITS ON MACHINED DIMENSIONS EXCEPT AS NOTED ANGULAR ± 1° 0' LINEAR .X = ± .1 .XX = ± .03 .XXX = ± .010 FRACTIONAL ± 1/32  BREAK ALL SHARP EDGES	DRAWN SKILES		<b>WESTERN</b> HEAVY MACHINERY DIVISION GEAR CORPORATION EVERETT, WASHINGTON	
	CHECK		SPACER, LIMIT SWITCH	
	ENGR SKILES		CENTER SECTION & P.M. COVER	
	WG B302882		SIZE <b>B</b> CODE IDENT NO. <b>16603</b> SCALE FULL	2150.281 B095 WT. — LB SHEET 1 OF 1