

THIS DOCUMENT CONTAINS INFORMATION PROPRIETARY TO WESTERN GEAR CORPORATION. ALL DESIGN, MANUFACTURING, REPRODUCTION, USE, PATENT AND SALES RIGHTS REGARDING THE SAME ARE HEREBY EXPRESSLY RESERVED BY WESTERN GEAR CORPORATION. THIS DOCUMENT IS SUBMITTED FOR REFERENCE PURPOSES ONLY AND SHALL NOT BE DISCLOSED TO ANY UNAUTHORIZED PERSON OR INCORPORATED INTO ANY OTHER PROJECT.

REVISIONS				
ZONE	LTR	DESCRIPTION	DATE	APPROVED
A		RELEASED FOR MANUFACTURE	1/11/71	G. Russ

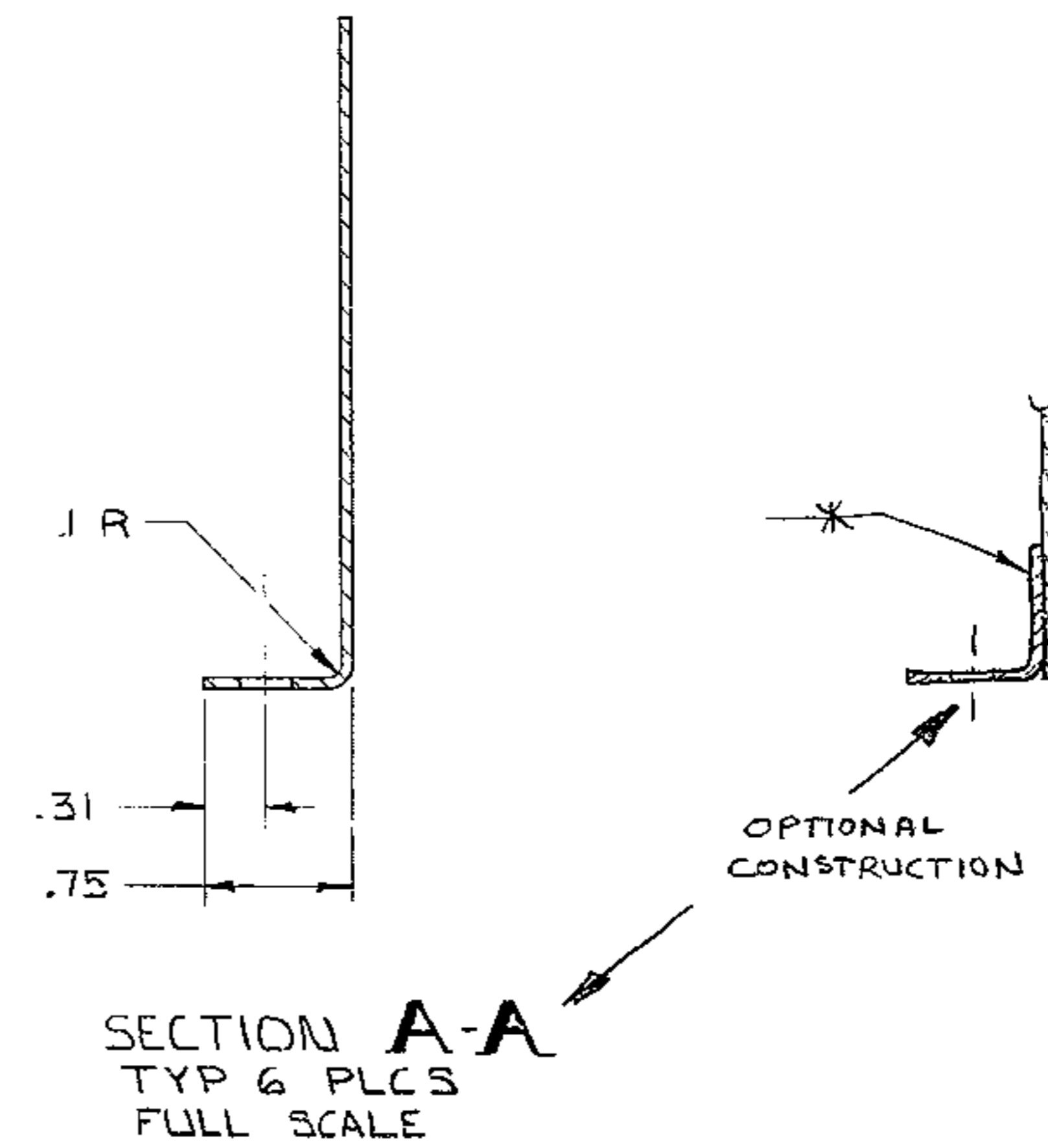
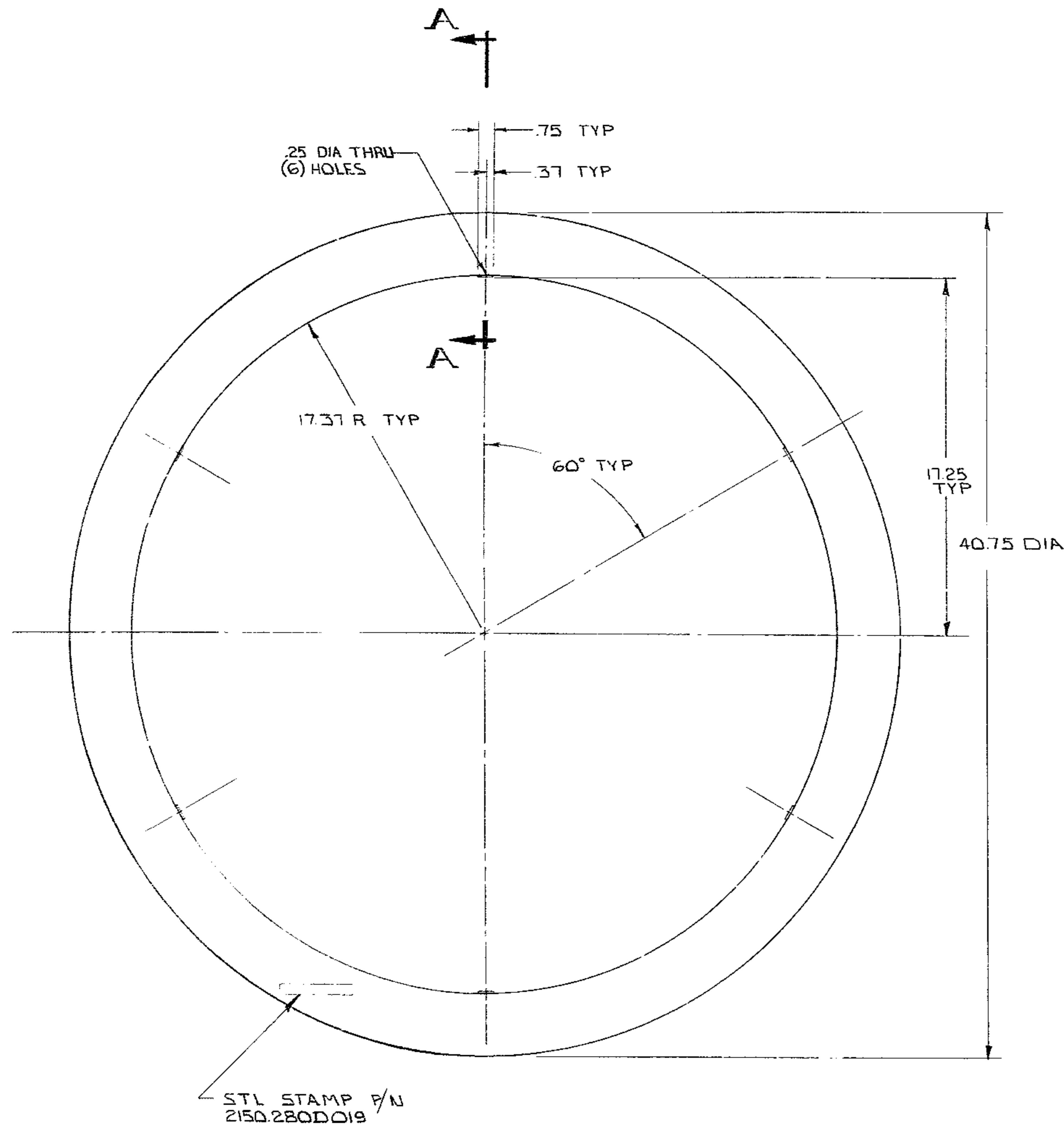

NEXT ASSY 2150.280E002 (WG N102B44)

FIND NO.	PART NO.	DESCRIPTION	QTY	MATERIAL	CODE IDENT
LIST OF MATERIAL (LM)					
LIMITS ON MACHINED DIMENSIONS EXCEPT AS NOTED ANGULAR = ± 1° 0'		DRAWN SKILES 18-6-70		WESTERN HEAVY MACHINERY DIVISION GEAR CORPORATION EVERETT, WASHINGTON	
LINEAR: .X = ± .1 .XXX = ± .010 .XX = ± .03 FRACTIONAL = ± 1/32		CHECK		BARRIER, GREASE - D.A. BRG CENTER SECTION	
BREAK ALL SHARP EDGES		ENGR			
MATERIAL 16 GA. (0598) x 40.75 DIA. STL - ASTM-A-415		WG E107685		SIZE CODE IDENT NO. REV D 16603 2150.280D019 A	
APPROVED				SCALE 1/4" WT LB SHEET / OF /	

1174