

THIS DOCUMENT CONTAINS INFORMATION PROPRIETARY TO WESTERN GEAR CORPORATION. ALL DESIGN, MANUFACTURING, REPRODUCTION, USE, PATENT, AND SALES RIGHTS REGARDING THE SAME ARE HEREBY EXPRESSLY RESERVED BY WESTERN GEAR CORPORATION. THIS DOCUMENT IS SUBMITTED FOR REFERENCE PURPOSES ONLY AND SHALL NOT BE DISCLOSED TO ANY UNAUTHORIZED PERSON OR INCORPORATED INTO ANY OTHER PROJECT.

REVISIONS				
ZONE	LTR	DESCRIPTION	DATE	APPROVED
-	A	REL TO MFG	10/30/69	

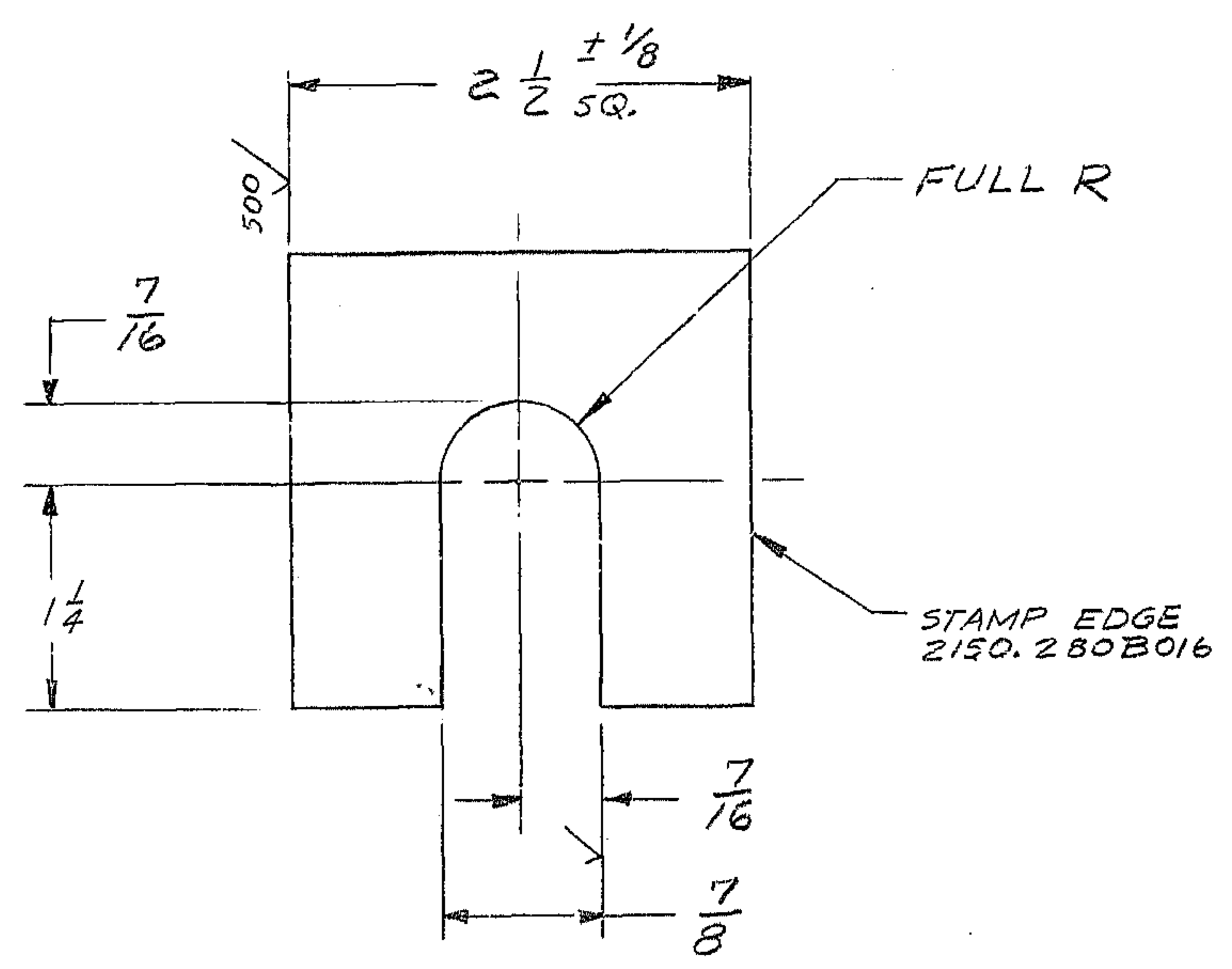

- NOTES:**
1. ALL DIMENSIONS ARE IN INCHES
 2. 125/ ALL MACHINED SURFACES
 3. MATERIAL: STL ASTM A-7 OR EQUIV. Φ 2 1/2 SQ. X 3/8 THK ~ MACHINE THICKNESS AS REQUIRED AT ASSY

REF. FILE 1174

NEXT ASSY: 2150.280E002 (W.G.N 102844)

WESTERN GEAR CORPORATION
 CONSTRUCTION PROJECTS
 DEPARTMENT
**APPROVED FOR
 PROCUREMENT**
 DATE 10/30/69

LIMITS ON MACHINED DIMENSIONS EXCEPT AS NOTED ANGULAR $\pm 1^\circ 0'$ LINEAR .X = $\pm .1$.XX = $\pm .03$.XXX = $\pm .010$ FRACTIONAL $\pm 1/32$ BREAK ALL SHARP EDGES	150" STELLAR TELESCOPE MTG	WESTERN GEAR CORPORATION HEAVY MACHINERY DIVISION EVERETT, WASHINGTON	
	DRAWN J. GRUVER CHECK G.R. 10/24/69 ENGR	SHIM, CENTRAL COVER - CENTER SECTION	
W.G.C 112750	SIZE B	CODE IDENT NO. 16603	2150.280B016
APPROVED	SCALE 1/1	WT.	LB SHEET 1 OF 1