

REVISIONS				
ZONE	LTR	DESCRIPTION	DATE	APPROVED
	A	REL. FOR MANUFACTURE PER AURA	3/12/69	PG
	B	Ø B .006 TIR WAS Ø B .003 TIR & Ø B .002 TIR	4/6/69	PG

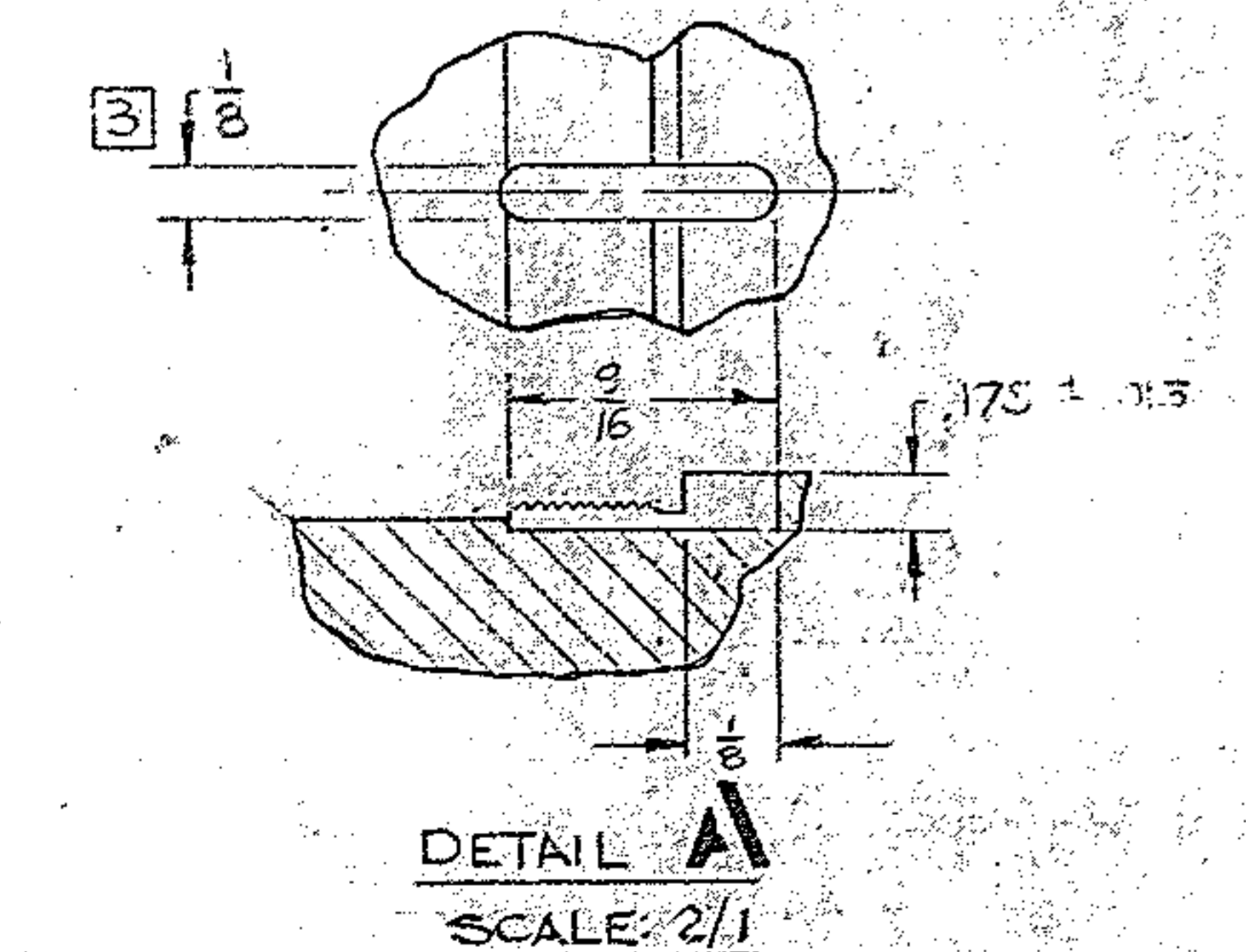
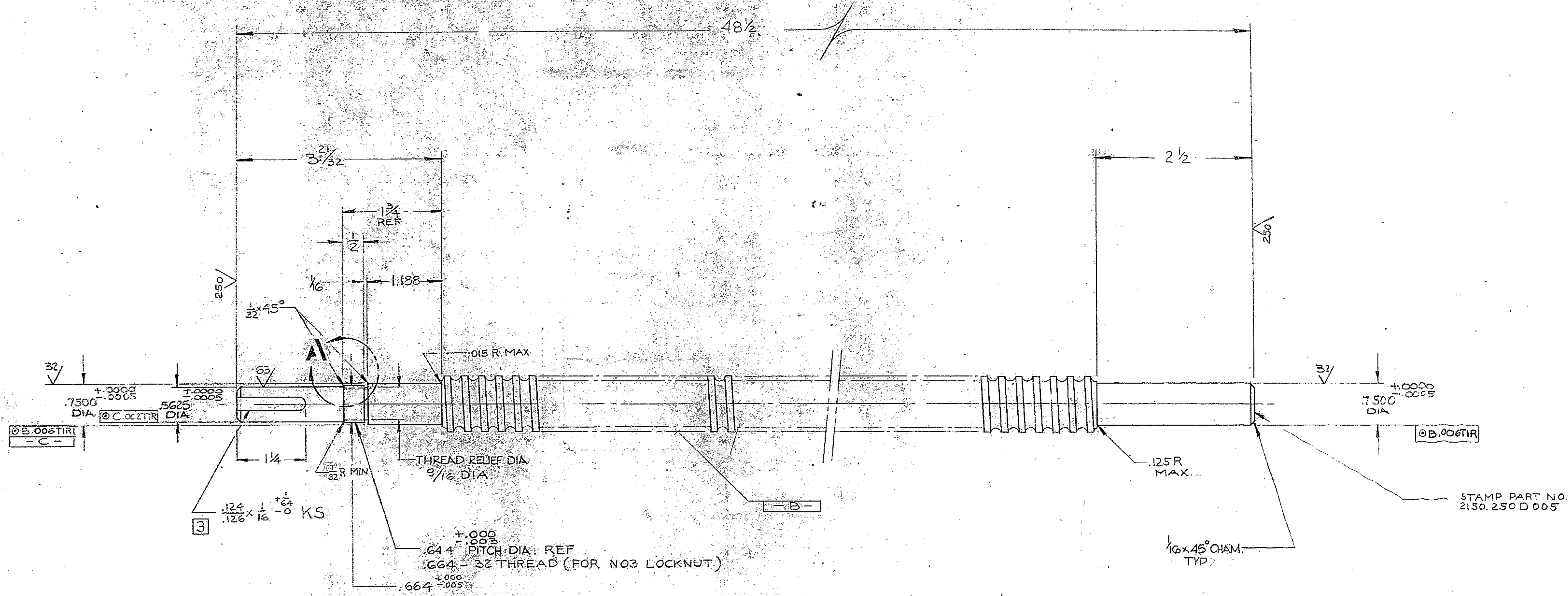

- NOTES:
- ALL DIMENSIONS ARE IN INCHES
  - FINISH  $\sqrt{32}$  EXCEPT AS NOTED
  - $\boxed{3}$  RADIAL ORIENTATION OF KS'S NOT IMPORTANT - KS MAY BE IN LINE

NEXT ASSY: 2150.250E002 (WGN 102 901)

WESTERN GEAR CORPORATION  
 CONSTRUCTION PROJECTS  
 DEPARTMENT  
 APPROVED FOR  
 PROCUREMENT  
*P. G. G. DATE 3/10/69*

FIND NO.	PART NO.	DESCRIPTION	QTY	MATERIAL	CODE IDENT
LIST OF MATERIAL (LM)					
LIMITS ON MACHINED DIMENSIONS EXCEPT AS NOTED		150" STELLAR TELESCOPE MOUNTING		HEAVY MACHINERY DIVISION EVERETT, WASHINGTON	
ANGULAR = ± 1° 0'		DRAWN LGOLD 4-2-68			
LINEAR:		CHECK <i>Y. M. G.</i> 7-9-68		SCREW, R.H., HORIZ. HORSESHOE ASSY	
X = ± .1    .XXX = ± .010		ENGR			
XX = ± .03    FRACTIONAL = ± 1/32		MATERIAL		SIZE CODE IDENT NO. REV <b>D 16603</b> 2150.250D 005 <b>B</b>	
BREAK ALL SHARP EDGES		MAKE OR PROCURE FROM SAGINAW		SCALE 1/16	
		NO 1000-0250-C2-SRT R.H.		WT ~ 12 LB SHEET OF	
		APPROVED ORIGINAL			

REF. FILE 1168