

4

3

2

1

REVISIONS				
ZONE	LTR	DESCRIPTION	DATE	APPROVED
A		RELEASED FOR MANUFACTURE	1-13-71	

STAMP PART NO.
2150.250C030

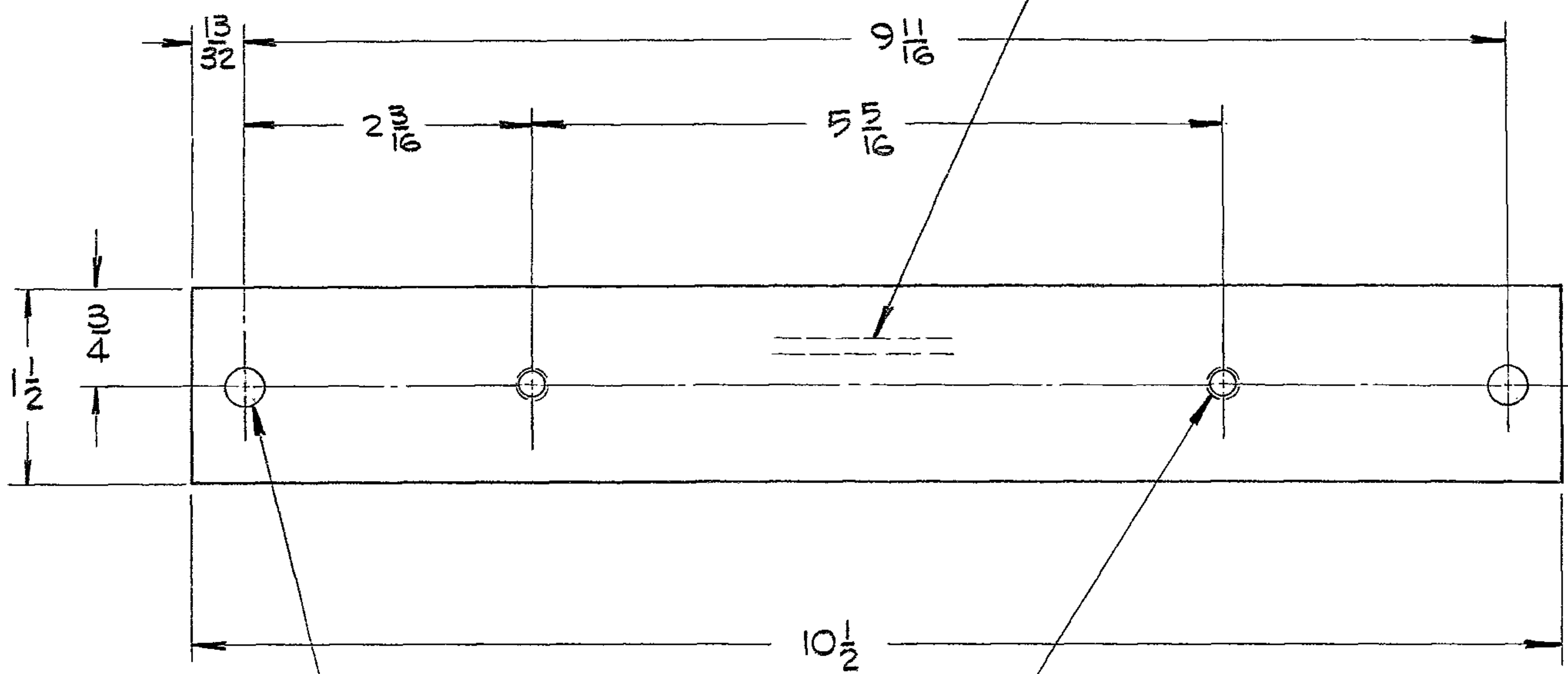

5/16 DRILL THRU
TYP (2) PLACES

#7 (.201) DRILL THRU
TAP 1/4-20 UNC-2B THRU
TYP (2) PLACES

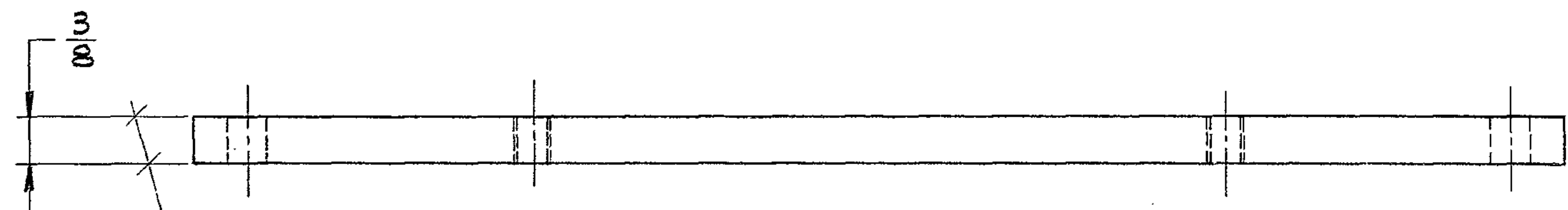

SURFACE GRIND BOTH SIDES
TO CLEAN UP

NOTES -
1. ALL DIMENSIONS ARE IN INCHES.

NEXT ASSY: 2150.250E002 (WGN102901) 1168

FIND NO.	PART NO.	DESCRIPTION	QTY	MATERIAL	CODE IDENT
LIST OF MATERIAL (LM)					
LIMITS ON MACHINED DIMENSIONS EXCEPT AS NOTED ANGULAR = ± 1° LINEAR: .X = ± .1 .XXX = ± .010 .XX = ± .03 FRACTIONAL = ± 1/32		150 INCH STELLAR TELESCOPE MOUNTING		Western GEAR CORPORATION	HEAVY MACHINERY DIVISION EVERETT, WASHINGTON
BREAK ALL SHARP EDGES		DRAWN White	1-13-71	PLATE, MOUNTING, CABLE HARNESS D.A. WRAP-UP	
MATERIAL		CHECK			
STL, ASTM-A36 OR EQ 3/8 x 1 1/2 x 10 1/2		ENGR SKILES	1-10-71		
		WGD107564		SIZE C	CODE IDENT NO. 16603
		APPROVED		2150.250C030	REV A
				SCALE	WT
				1	LB SHEET 1 OF 1