

4

3

2

1

REVISIONS				
ZONE	LTR	DESCRIPTION	DATE	APPROVED
	A	REL. FOR MANUFACTURE		

13/32 DR. THRU
(4) HOLES EQ. SPA.
ON 5 7/8 D.B.C.

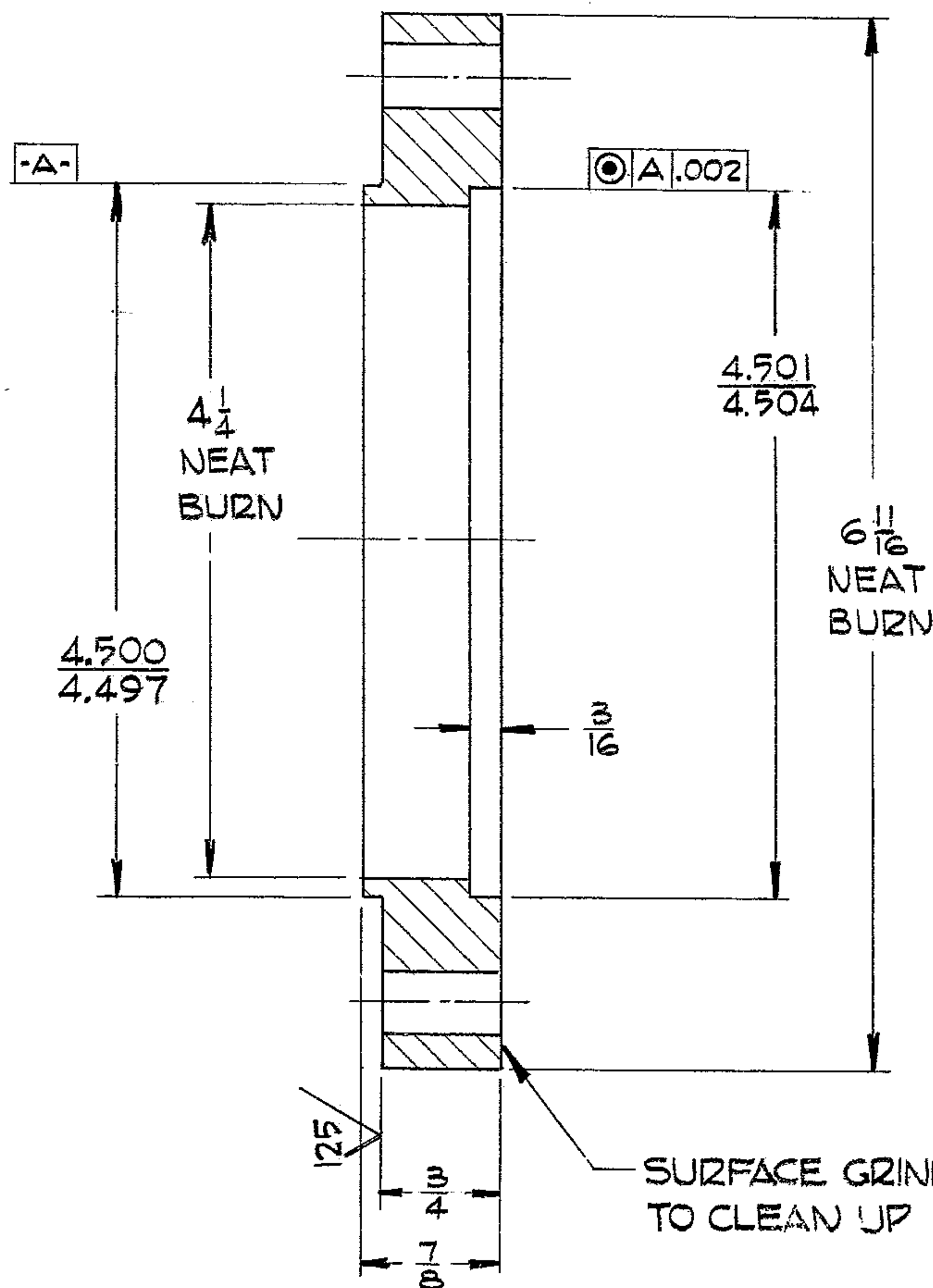
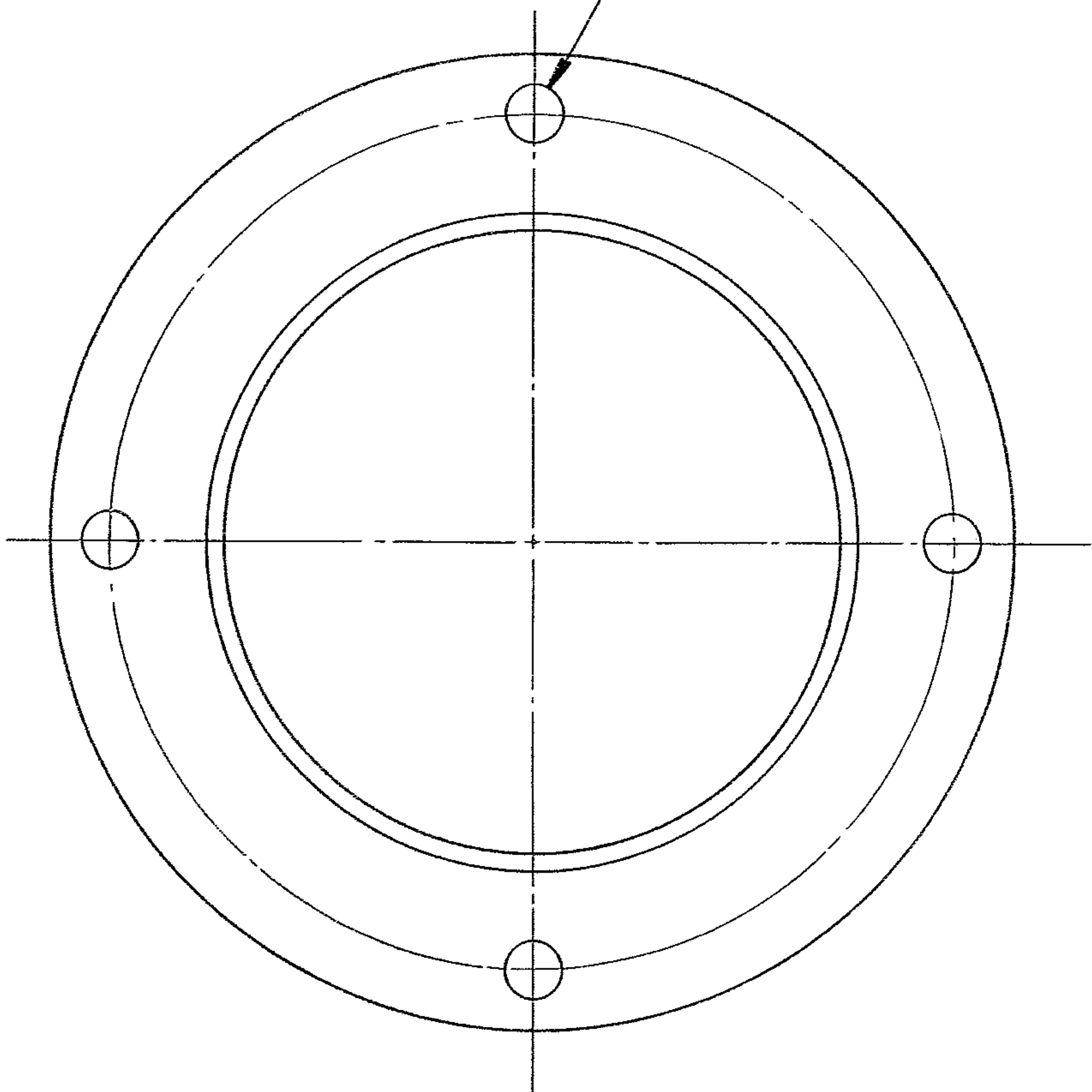

NOTES:
1. ALL DIMENSIONS ARE IN INCHES.
2. TAG WITH PART NO. 2150.250C027

NEXT ASSY: 2150.250E002 (WGN102901)

FILE 1168

FIND NO.	PART NO.	DESCRIPTION	QTY	MATERIAL	CODE IDENT
LIST OF MATERIAL (LM)					
LIMITS ON MACHINED DIMENSIONS EXCEPT AS NOTED ANGULAR = ± 1° 0'		150 INCH STELLAR TELESCOPE MOUNTING		WESTERN HEAVY MACHINERY DIVISION GEAR CORPORATION EVERETT, WASHINGTON	
LINEAR: X = ± .1 .XXX = ± .010 .XX = ± .03 FRACTIONAL = ± 1/32		DRAWN <i>White</i>	12-22-70	COUDE 4 LIFT MOTOR SPACER HORSESHOE ASSEMBLY	
BREAK ALL SHARP EDGES		CHECK			
MATERIAL		ENGR <i>SKILES</i>			
STL-ASTM A-36 1 x 6 11/16 DIA		WGD107684		SIZE	CODE IDENT NO.
		APPROVED		C	16603
				2150.250C027	REV A
				SCALE 1/1	WT
				LB	SHEET 1 OF 1

107684