

THIS DOCUMENT CONTAINS INFORMATION PROPRIETARY TO WESTERN GEAR CORPORATION. ALL DESIGN, MANUFACTURING, REPRODUCTION, USE, PATENT, AND SALES RIGHTS REGARDING THE SAME ARE HEREBY EXPRESSLY RESERVED BY WESTERN GEAR CORPORATION. THIS DOCUMENT IS SUBMITTED FOR REFERENCE PURPOSES ONLY AND SHALL NOT BE DISCLOSED TO ANY UNAUTHORIZED PERSON OR INCORPORATED INTO ANY OTHER PROJECT.

REVISIONS				
ZONE	LTR	DESCRIPTION	DATE	APPROVED
	A	RELEASED FOR MANUFACTURE	6-29-71	SKILES

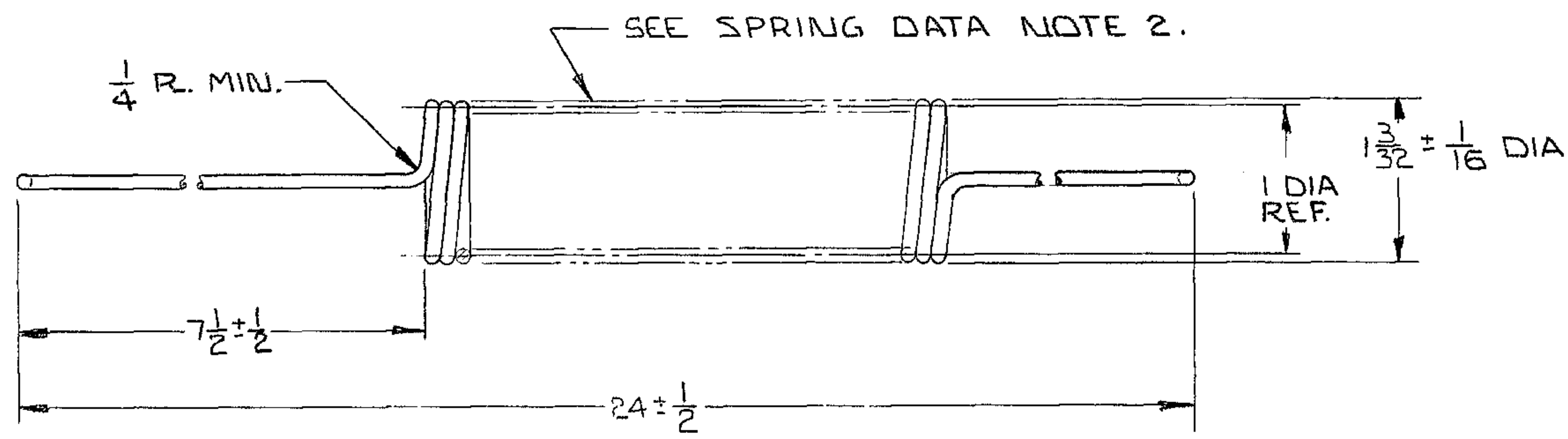
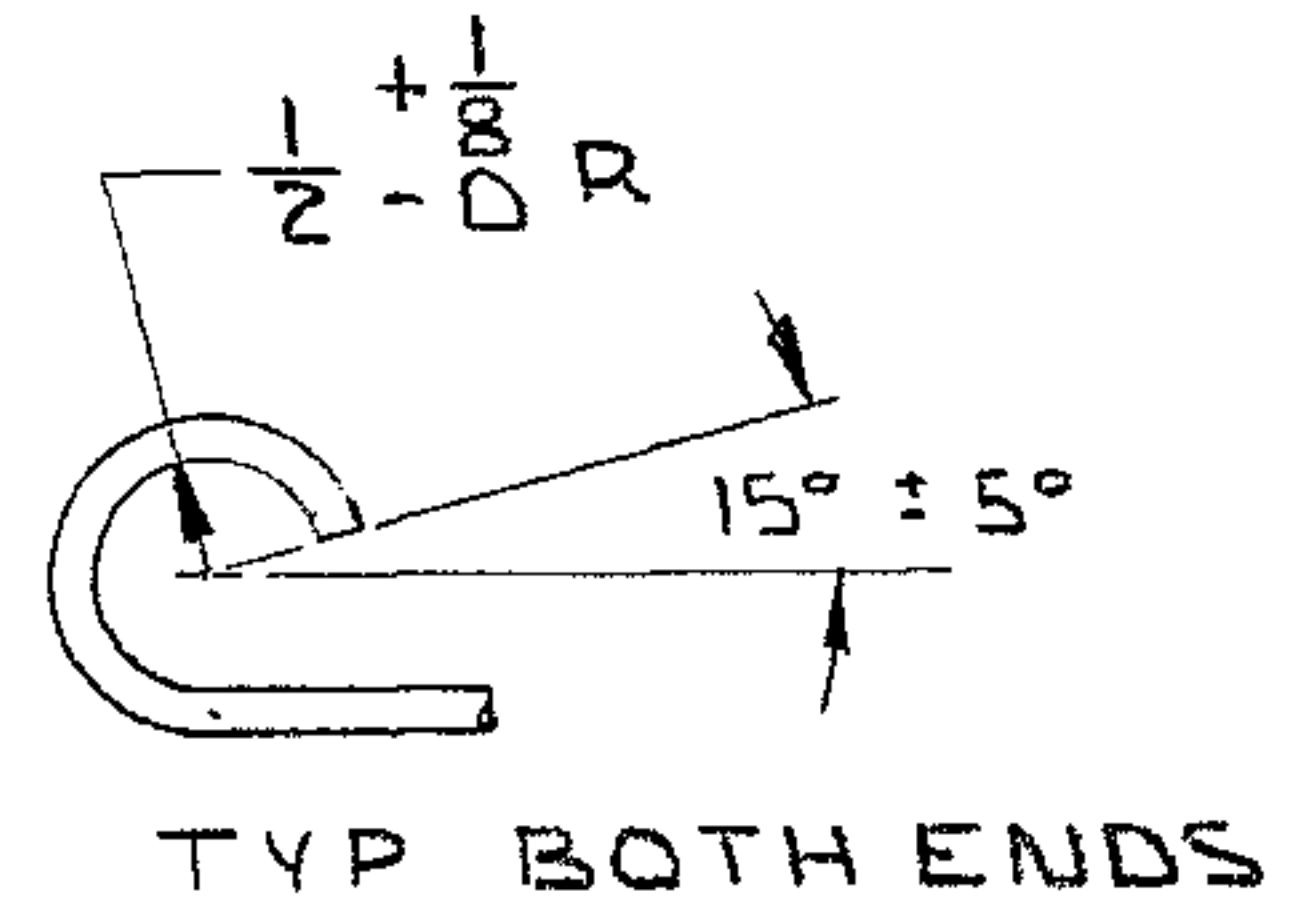

- NOTES:
 1. TAG WITH P/N 2150.250B080
 2. SPRING DATA:
 MAT'L: MUSIC WIRE AISI 1085 .091 DIA
 NO. OF TURNS: 100 TURN CLOSE WOUND
 MAX. INTIAL TENSION: 2 LBS
 MEAN DIA: 1.00 INCH REF.
 SPRING CONSTANT: .994 LB/IN

REF. 1168

NEXT ASSY: 2150.250E002, N102901

LIMITS ON MACHINED DIMENSIONS EXCEPT AS NOTED ANGULAR $\pm 1^\circ 0'$ LINEAR .X = $\pm .1$.XX = $\pm .03$.XXX = $\pm .010$ FRACTIONAL $\pm 1/32$ BREAK ALL SHARP EDGES	DRAWN	LDS		
	CHECK			
	ENGR	SKILES 6-29-71		
	APPROVED	WG B302830		
WESTERN GEAR CORPORATION		HEAVY MACHINERY DIVISION EVERETT, WASHINGTON		
SPRING, EXTENSION, COUDE 4 CABLE WRAP UP HORSESHOE ASSEMBLY		SIZE	CODE IDENT NO.	REV
		B	16603	2150.250B080 A
SCALE 1:1		WT.	SHEET OF	