

5

4

3

2

1

THIS DOCUMENT CONTAINS INFORMATION PROPRIETARY TO WESTERN GEAR CORPORATION. ALL DESIGN, MANUFACTURING, REPRODUCTION, USE, PATENT, AND SALES RIGHTS REGARDING THE SAME ARE HEREBY EXPRESSLY RESERVED BY WESTERN GEAR CORPORATION. THIS DOCUMENT IS SUBMITTED FOR REFERENCE PURPOSES ONLY AND SHALL NOT BE DISCLOSED TO ANY UNAUTHORIZED PERSON OR INCORPORATED INTO ANY OTHER PROJECT.

REVISIONS				
ZONE	LTR	DESCRIPTION	DATE	APPROVED
	A	RELEASED FOR CONSTR.	3/11/69	PG.
	B	1.030 WAS .812, 1 1/4 LG WAS 1 LG	5-18-71	JW

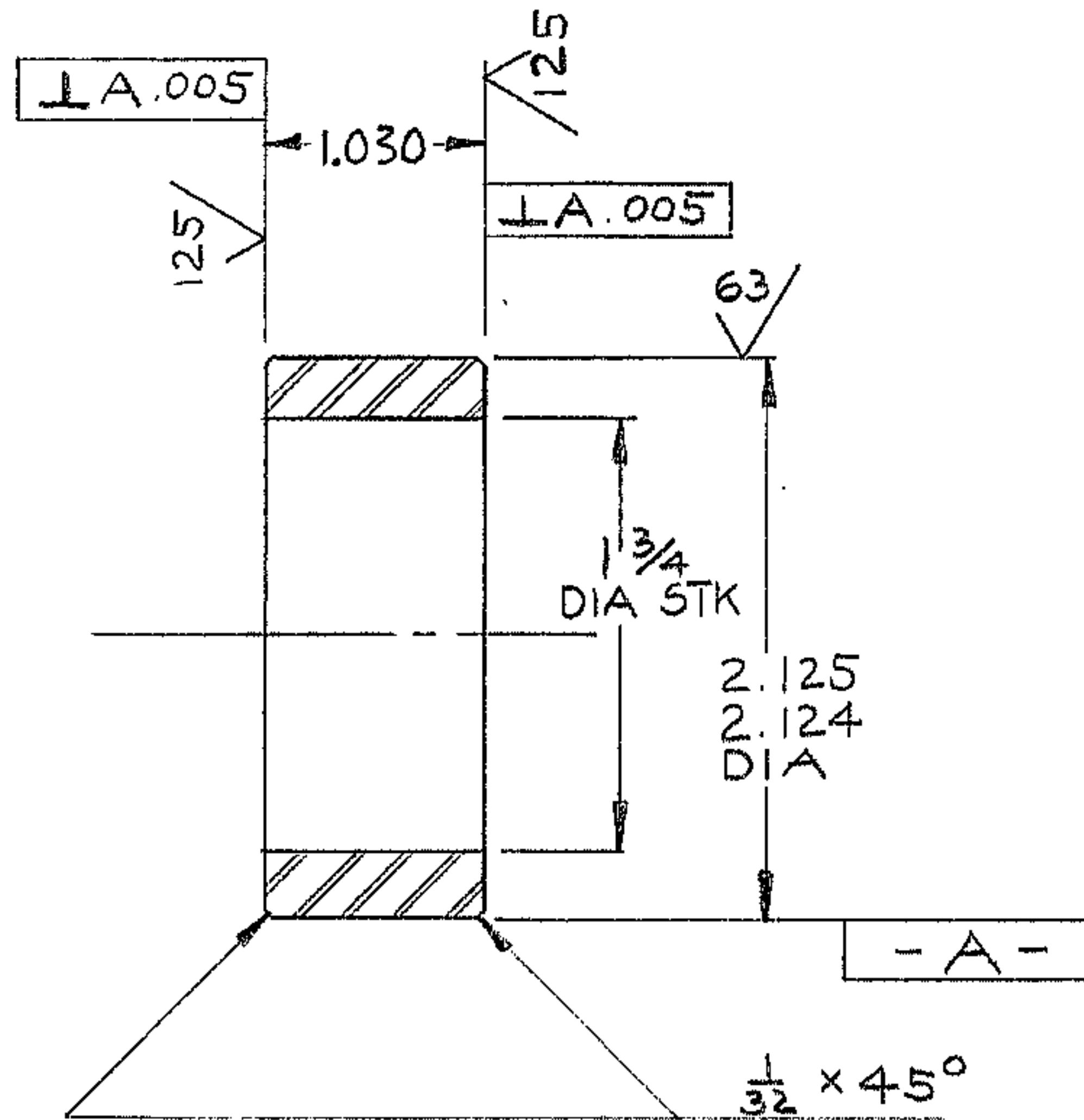

NOTES :

1. ALL DIMENSIONS ARE IN INCHES
2. MATL.: STL TUBE
2 1/4 O.D. x 1 3/4 I.D. x 1 1/4 LG.
MT 1015 OR EQ.
3. TAG PART NO. 2150.250 B 023

REF. FILE 1168

WESTERN GEAR CORPORATION
CONSTRUCTION PROJECTS
DEPARTMENT
APPROVED FOR
PROCUREMENT
P. Grefe DATE 3/11/69

NEXT ASSY 2150.250 E 002. (W.G.N 102 901)

LIMITS ON MACHINED DIMENSIONS EXCEPT AS NOTED ANGULAR ± 1° 0' LINEAR .X = ± .1 .XX = ± .03 .XXX = ± .010 FRACTIONAL ± 1/32 BREAK ALL SHARP EDGES	150 IN STELLAR TELESCOPE MOUNTING	Western GEAR CORPORATION HEAVY MACHINERY DIVISION EVERETT, WASHINGTON
	DRAWN P. GREFE CHECK P. GREFE ENGR	
	W.G. C 112 737	SIZE B CODE IDENT NO. 2150.250 B 023 REV B
	APPROVED	SCALE 1/1 WT. LB SHEET 1 OF 1