

REVISIONS

ZONE	LTR	DESCRIPTION	DATE	APPROVED
	A	5/8 WAS 1/4 .563 WAS .938	6-28-71	LDS

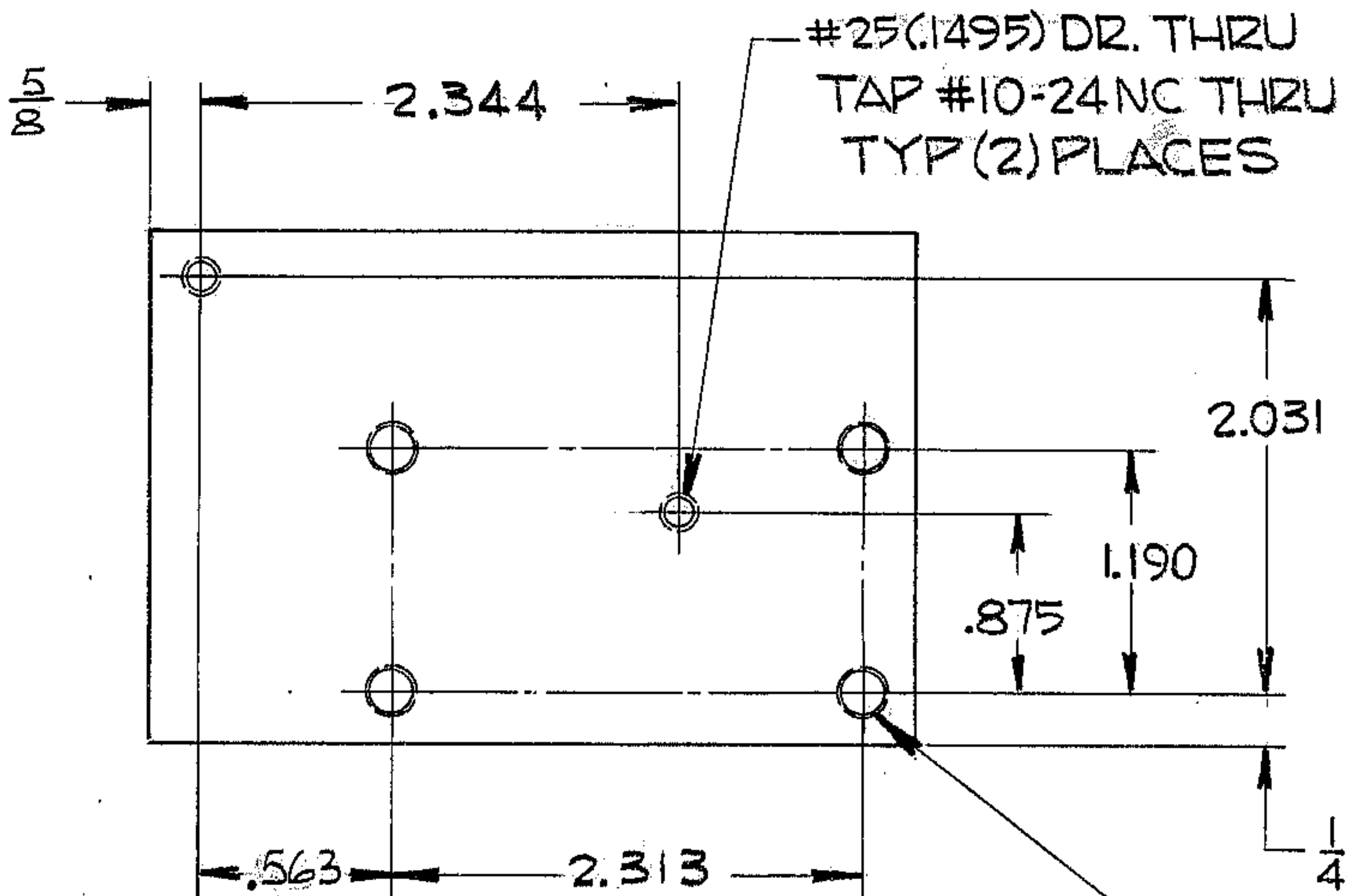

NOTES:

- MAT'L - STL #2, 1/8 x 2 1/2 x 3 3/4, ASTM A-36.
- SURFACE GRIND BOTH SIDES TO CLEAN UP.
- STEEL STAMP PART NO. 250.250A082.

REF. FILE 1168

NEXT ASSY 2150.250E002 (WGN102901)

LIMITS ON MACHINED DIMENSIONS EXCEPT AS NOTED

ANGULAR ± 1° 0'
 LINEAR
 X = ± .1
 XX = ± .03
 XXX = ± .010
 FRACTIONAL ± 1/32

BREAK ALL SHARP EDGES

WESTERN
 GEAR CORPORATION

HEAVY MACHINERY DIVISION
 EVERETT, WASHINGTON

DRAWN *White 3/26/71*

CHECK

ENGR *SKides 5/27/71*

L.S. MOUNTING PLATE

WGA 301344

APPROVED

SIZE A	CODE IDENT NO. 16603	2150.250A082	REV A
------------------	--------------------------------	---------------------	-----------------

SCALE 1/1 WT. LB SHEET 1 OF

A-301344