

THIS DOCUMENT CONTAINS INFORMATION PROPRIETARY TO WESTERN GEAR CORPORATION. ALL DESIGN, MANUFACTURING, REPRODUCTION, USE, PATENT, AND SALES RIGHTS REGARDING THE SAME ARE HEREBY EXPRESSLY RESERVED BY WESTERN GEAR CORPORATION. THIS DOCUMENT IS SUBMITTED FOR REFERENCE PURPOSES ONLY AND SHALL NOT BE DISCLOSED TO ANY UNAUTHORIZED PERSON OR INCORPORATED INTO ANY OTHER PROJECT.

REVISIONS				
ZONE	LTR	DESCRIPTION	DATE	APPROVED

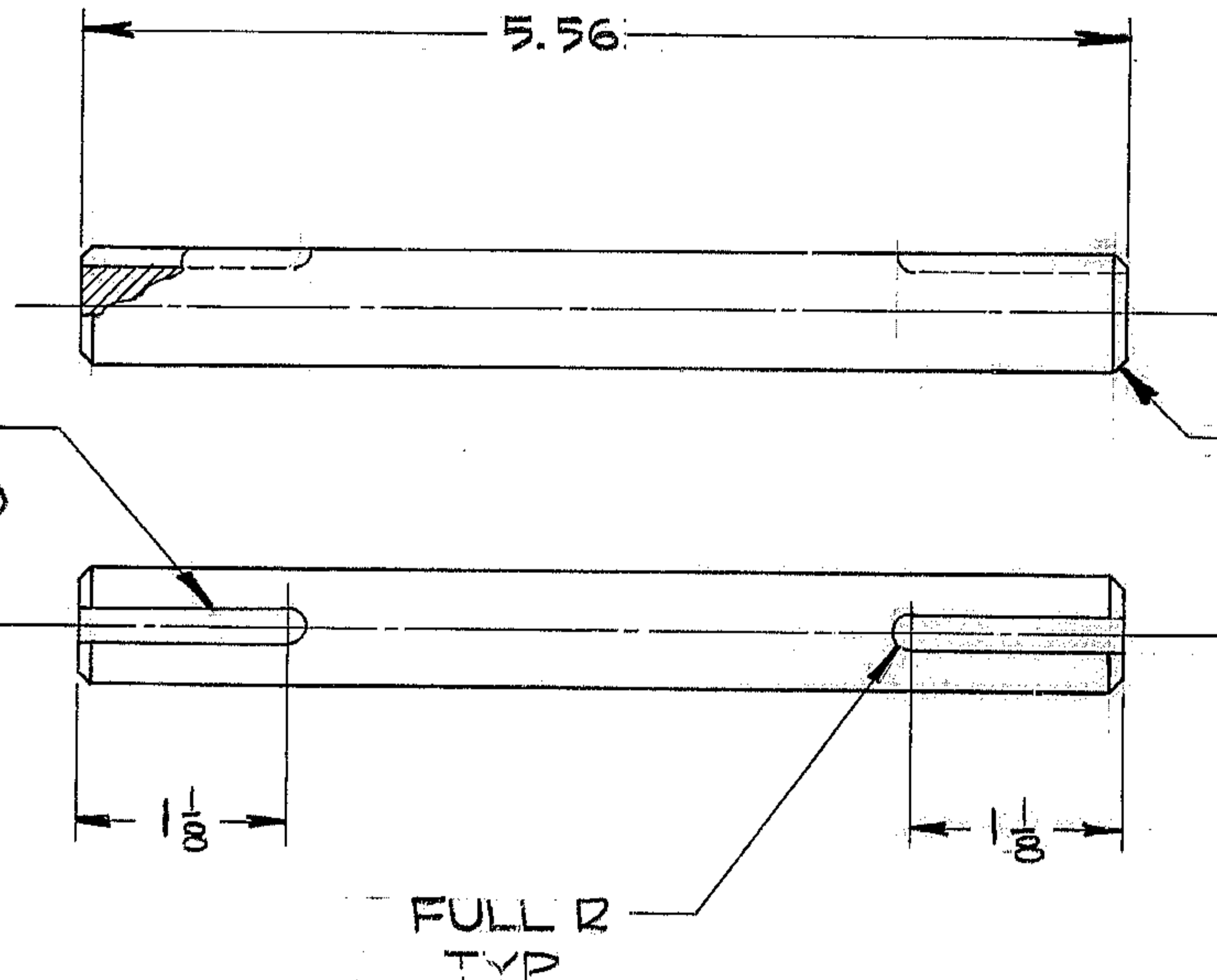

- NOTES:
1. ALL DIMENSIONS ARE IN INCHES
 2. MATL: PRECISION SHAFTING
.6245/.6255 DIA X 5 3/4 LG OR
C.D. BAR .625 ±.0002 DIA
 3. TAG WITH P/N 2150.240B036

REF. FILE 4167

NEXT ASSY: 2150.240E002 (WGN102993)

LIMITS ON MACHINED DIMENSIONS EXCEPT AS NOTED ANGULAR ± 1° 0' LINEAR X = ± .1 .XX = ± .03 .XXX = ± .010 FRACTIONAL ± 1/32 BREAK ALL SHARP EDGES	DRAWN <i>White 7/14/71</i>	WESTERN HEAVY MACHINERY DIVISION GEAR CORPORATION EVERETT, WASHINGTON		
	CHECK	SHAFT, CONNECTING CASSEGRAIN RAMP ASSY		
	ENGR <i>SKILES 7-22-71</i>	SIZE B	CODE IDENT NO. 16603	2150.240B036 REV
	WGB302913 APPROVED	SCALE 1/1	WT. LB	SHEET 1 OF 1